

SLAMP:

Compendium 2015/2016

ADAPTABLE
SENSUAL
MYSTERIOUS
INNOVATIVE
ACCESSIBLE
RELIABLE
ASPIRATIONAL
ORIGINAL
RESOURCEFUL
EXPERIMENTAL
SUGGESTIVE

SLAMP

THE LEADING LIGHT

ALL RIGHTS RESERVED © SLAMP S.p.A. 2015/2016

EDITOR

Roberto Ziliani

CONCEPT

Nigel Coates

DESIGN

Luca Mazza

PHOTOS

Lorenzo Sechi

POST PRODUCTION

Ezio Gosti

PRE-PRINTED & PRINTED

Tipolitografica CS - Padova - Italy

Slamp S.p.A.

Via Tre Cannelle, 3

00040 - Pomezia, Roma, Italy

tel. +39 06 916 23 91, fax +39 06 916 23 933

info@slamp.com - www.slamp.com

SLAMP:

Compendium 2015/2016

ALL SLAMP PRODUCTS ARE PRODUCED AND ASSEMBLED IN ITALY

Products are patented throughout the world and conform to the leading electrical safety standards:



SLAMP S.p.A. reserves the right to modify price list and/or products without notice in the event of commercial conditions rendering this necessary. Slight differences of colour in some products in this catalogue are due to the processes involved in printing.

SLAMP S.p.A. si riserva il diritto di apportare modifiche al listino e ai prodotti senza alcun preavviso, qualora le condizioni commerciali lo rendessero necessario. Difformità di colore di alcuni prodotti sul presente catalogo sono dovute a processi di stampa.

CULTURA ARTIJDIO

 ARIA	p 78	 FLORA	p 170
 ATLANTE	p 350	 GEMMY	p 212
 AURORA	p 246	 GINETTA	p 258
 AVIA	p 90	 GIRAFIORE	p 356
 BACH	p 206	 GOCCIA	p 306
 BATTISTA	p 312	 HARRIS	p 352
 BIOS	p 316	 HELIOS	p 270
 CACTUS	p 226	 HUGO	p 140
 CEREMONY	p 220	 ILLUMINATI	p 286
 CHANTAL	p 64	 LA LOLLO	p 156
 CHAPEAU	p 300	 LAS PALMAS	p 360
 CHARLOTTE	p 74	 LILLIBET	p 236
 CLIZIA	p 98	 LIZA	p 128
 COMODINA	p 236	 LUÌ	p 342
 CRAZY DIAMOND	p 332	 MEDUSA	p 232
 CREATURES	p 336	 MILLE BOLLE	p 264
 CROCCO	p 148	 MIRAGE	p 164
 DAFNE	p 326	 PACIS	p 340
 DEVIL	p 322	 PUNCTUM	p 292
 DIAMOND	p 276	 SUPERMORGANA	p 280
 ECSTACITY	p 362	 SUPERSTAR	p 296
 ÉTOILE	p 118	 VELI	p 180
 FARETTO	p 240	 VENTI	p 346
 FIORELLA	p 198	 WOODY	p 252

SUSPENSIONS







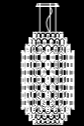

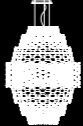

























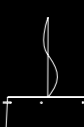
 ARIA p 78	 ATLANTE p 350	 AVIA p 90	 BIOS p 316	 CACTUS p 226	 CEREMONY p 220
 CHANTAL p 64	 CHAPEAU p 300	 CHARLOTTE p 74	 CLIZIA p 98	 CRAZY DIAMOND p 332	 CREATURES p 336
 CROCCO p 148	 DAFNE p 326	 DEVIL p 322	 ÉTOILE p 118	 FARETTO p 240	 FIORELLA p 198
 FLORA p 170	 GEMMY p 212	 GINETTA p 258	 GIRAFIORE p 356	 GOCCIA p 306	 HARRIS p 352
 HUGO p 140	 LA LOLLO p 156	 LILLIBET p 236	 LIZA p 128	 LUÌ p 342	 MEDUSA p 232
 MILLE BOLLE p 264	 SUPERMORGANA p 280	 SUPERSTAR p 296	 VELI p 180	 WOODY p 252	

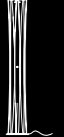
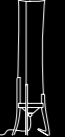

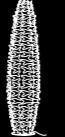






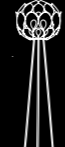









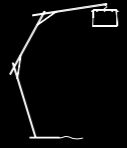
TABLE LAMPS

 ATLANTE p 350	 BACH p 206	 BIOS p 316	 CACTUS p 226	 CLIZIA p 98	 CHAPEAU p 300
 COMODINA p 236	 DAFNE p 326	 DIAMOND p 276	 FARETTO p 240	 FIORELLA p 198	 GEMMY p 212
 LAS PALMAS p 360	 LIZA p 128	 MILLE BOLLE p 264	 VELI p 180	 VENTI p 346	

CEILING LAMPS

 AURORA p 246	 BIOS p 316	 CLIZIA p 98	 CROCCO p 148	 DAFNE p 326	 ÉTOILE p 118
 PACIS p 340	 VELI p 180	 VENTI p 346			

FLOOR LAMPS

 BACH p 206	 BATTISTA p 312	 BIOS p 316	 CACTUS p 226	 CLIZIA p 98	 CHAPEAU p 300
 DAFNE p 326	 DIAMOND p 276	 ECSTACITY p 362	 FIORELLA p 198	 FLORA p 170	 GEMMY p 212
 GINETTA p 258	 GIRAFIORE p 356	 HELIOS p 270	 LAS PALMAS p 360	 LIZA p 128	 MILLE BOLLE p 264
 PUNCTUM p 292	 VENTI p 346	 WOODY p 252			

WALL LAMPS

 BIOS p 316	 CLIZIA p 98	 CROCCO p 148	 DAFNE p 326	 FIORELLA p 198	 GINETTA p 258
 ILLUMINATI p 286	 LILLIBET p 236	 MEDUSA p 232	 MILLE BOLLE p 264	 MIRAGE p 164	 PUNCTUM p 292
 VELI p 180	 VENTI p 346				

luce^e ITALIANITA'



Roberto Ziliani,
CEO Slamp

Light is an essential element of human life: one comes to light, one highlights and one brings light. It reveals and unveils, determining the mood and beating the rhythm of existence. An immaterial presence that our painters, filmmakers and photographers have been able to capture and transform into works of art.

At Slamp we decompose light, analysing its lumens, CRI and wattage, but as heirs of an all Italian culture and passion, we choose to go further, measuring also its ability to generate emotions, reproduce stage effects, recall brilliance and outstanding natural beauty.

Give depth to reality generating a relation amongst project, function, aesthetics and innovation.

La luce è elemento imprescindibile della vita umana: si viene alla luce, si mette in luce e si riporta alla luce. Rivela e svela, determina l'umore e scandisce i ritmi dell'esistenza. Presenza immateriale che i nostri pittori, registi e fotografi hanno saputo catturare e trasformare in opere d'arte.

Noi di Slamp la scomponiamo analizzandone lumen, CRI e Watt ma, eredi di una cultura e di una passione tutta italiana, scegliamo di andare oltre misurandola anche in capacità di generare emozioni, riprodurre effetti scenografici, richiamare bagliori e suggestioni naturali.

Dare profondità alla realtà mettendo in relazione progetto, funzione, estetica e innovazione.

PASSIONE PASSIONE

DISCOVER *and* SHARE *by Luca Mazza*

When we pause and quickly scroll down the camera roll, we realise how much we have run, travelled, explored, discovered, experienced and recognised.

In the following pages we have used our photographs... those “stolen” from the Ballarò market and Kalsa of Palermo, that of Zaha Hadid’s DDP in Seoul and of the Happy Buddha take after the descent of the Mekong during the summer monsoon. Then there is the artistic Rome, that seen every day walking around the Cloister of Bramante and Palazzo Barberini. The snapshots of the regular flights from Rome to London, with late night landings at Heathrow, and uphill walks in Wiltshire and Florida palm trees decorated with Christmas lights.

We have combined them with Slamp’s new lamp collections in a set built ad hoc, having acknowledged in each one the beauty of natural forms, the projects of great architecture and culture of classical art. We would not have seen it had we not preferred a night flight to one in broad daylight, without trying new food or wear trekking boots instead of high heels. We would not have seen this without our uncontrollable desire to search and discover. To share what curiosity led us to experience and recognise.

Quando ci fermiamo e scolliamo velocemente il rullino fotografico, ci rendiamo conto di quanto abbiamo corso, percorso, esplorato, scoperto, conosciuto e riconosciuto.

Nelle prossime pagine abbiamo usato le nostre foto... quelle “rubate” tra il mercato di Ballarò e la Kalsa di Palermo, quella del DDP di Zaha Hadid a Seoul e del Buddha Felice scattata dopo la discesa del Mekong durante i monsoni estivi. C’è poi la Roma dell’Arte, quella che osserviamo ogni giorno passeggiando tra il Chiostro del Bramante e Palazzo Barberini. Gli scatti dei periodici voli Roma-Londra con atterraggi a Heathrow a notte fonda, delle camminate in salita nel Wiltshire e delle palme della Florida addobbate con luminarie di Natale. Le abbiamo accostate alle nuove collezioni di lampade Slamp in un set costruito ad hoc, dopo aver riconosciuto in ciascuna di esse la bellezza delle forme naturali, il progetto delle grandi architetture e la cultura dell’arte classica. Non lo avremmo visto senza preferire un volo notturno a uno in pieno giorno, senza provare un cibo nuovo o indossare le scarpe da trekking al posto dei tacchi alti. Non lo avremmo visto senza la nostra incontenibile voglia di cercare e scoprire. Condividere ciò che la curiosità ci ha portato a conoscere e riconoscere.









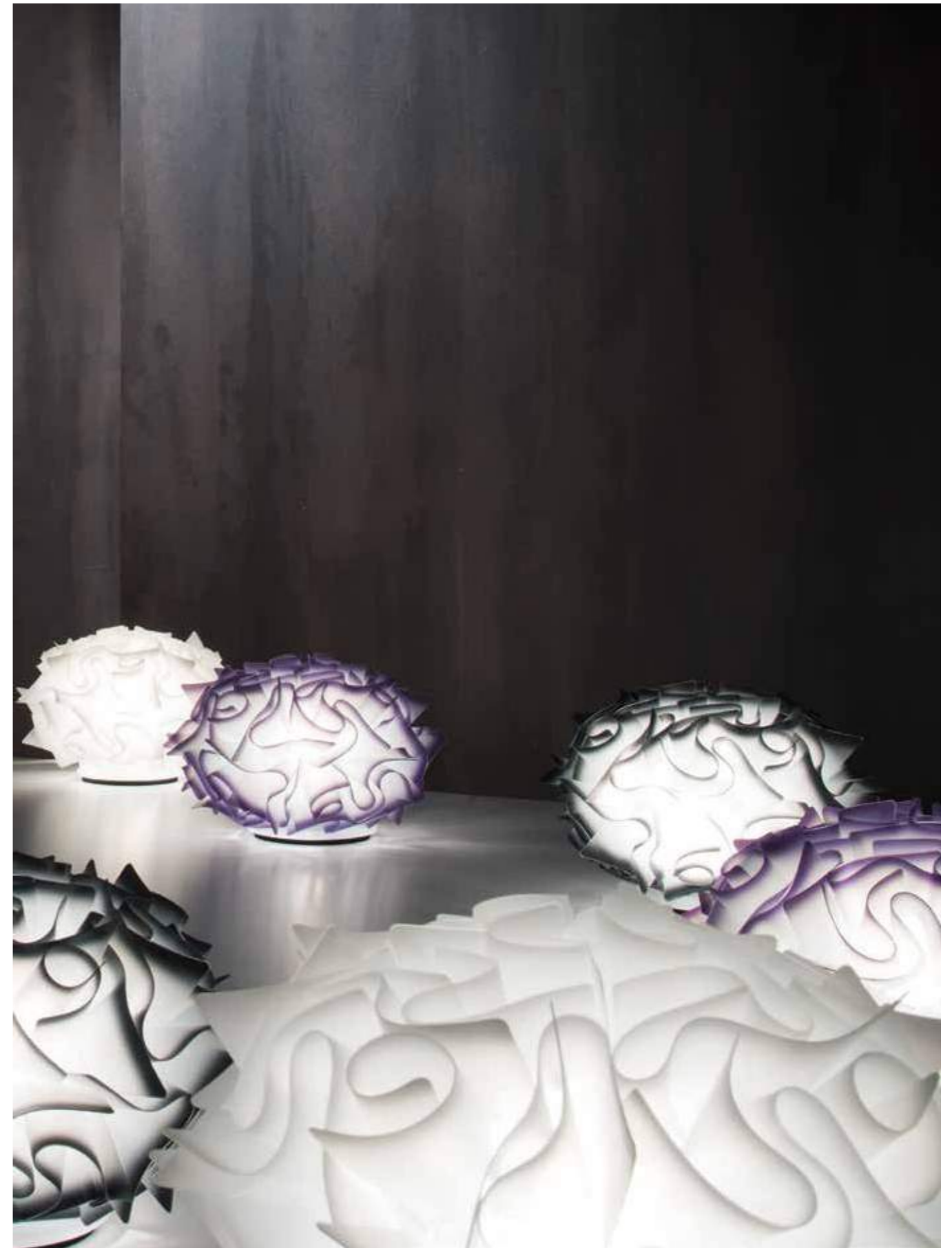
























Sorelle Fontana's dress at Musei Capitolini courtyard, Rome 1952. Photo by Regina Relang. - Courtesy Mittelner Stadtmuseum, Sammlung Fotografien, Archiv Relang.



BELLEZZA

BELLEZZA



LUMINOTECA

by Domitilla Dardi

A simple and effective idea: to create three-dimensional shapes that arise from a flat sheet of material. It is the starting point for the work of a fashion designer, with textiles, and likewise for Slamp, with the surfaces of materials. If the aim is not to clothe a body but dress an entire space, only one raw material makes this possible: light.

The design vision is combined with material research to transform a surface into objects that convey the most magical of substances.

Un'idea semplice ed efficace: creare forme tridimensionali che nascono da un foglio di materiale piano. È il punto di partenza del mestiere dello stilista di moda, con i tessuti, e anche quello di Slamp, con le superfici materiche. Se poi l'ambizione è quella di vestire non un corpo ma uno spazio intero, ecco che la materia prima possibile è solo una: la luce.

La visione del design si unisce alla ricerca sui materiali per trasformare una superficie in oggetti che veicolano la più magica della materie. Un'energia vitale

↑ *Aria and Aria collection, Tokyo Opera City Art Gallery.*

A vital energy that is shaped according to interpretations and points of view potentially endless, vibrant with emotion, bearer of both beauty and charm, renewed in every project and the turning on of every light switch.

Slamp offers the opportunity to give substance to a desire: channelling elusive light into an object that corresponds to the idea of original and personal lighting; and achieving this with the aid of lamps that lend themselves to the “masterly game of volumes under the light”. The sheets of material are in turn cut, folded, perforated, and composed to give shape to the idea. Whether it's an tomographic architectural vision (Hadid) or multi-perspective (Fuksas), a movement of light and air (Rachele), a playful presence (Coates), a modern classic (Giovannoni), a poetic atmosphere of the past (Bozzoli) or of light beams that smack of the future (Hugo). Craftsmanship that necessitates technical knowledge but also manual skills, treating each piece of the series with bespoke tailoring, driven by the curiosity for the next challenge. As always only Italian companies know how to do: making a multiple unique, through the passion for their work.

che viene plasmata secondo interpretazioni e chiavi di lettura potenzialmente infinite, vibrante di emozione, portatrice di bellezza e suggestioni che si rinnovano in ogni progetto e a ogni accensione.

Slamp offre la possibilità di dare corpo a un desiderio: incanalare la sfuggente luce in un oggetto che corrisponde a un'idea di illuminazione originale e personale. E di farlo attraverso lampade che si prestano al “gioco sapiente dei volumi sotto la luce”. Le lastre materiche vengono di volta in volta tagliate, piegate, forate, composte per dare forma all'idea. Che si tratti di una visione architettonica tomografica (Hadid) o multi-prospettica (Fuksas), di un movimento leggero e aereo (Rachele), di una presenza giocosa (Coates), di un classico moderno (Giovannoni), di una poetica atmosfera di altri tempi (Bozzoli) o di un fascio luminoso che sa di futuro (Hugo).

Per farlo viene usata conoscenza tecnica ma anche manualità, trattando ogni pezzo di serie con cura sartoriale, spinti dalla curiosità per la prossima sfida. Come solo le aziende italiane da sempre sanno fare: rendendo unico un multiplo attraverso la passione per il proprio lavoro.

“ If the aim is to dress an entire space, only one raw material makes this possible: light ”

↑ *Domitilla Dardi (Historian and Curator of Design)*

↓ *Black Box, Slamp HQ.*



Doriana and Massimiliano

FUKSAS



Doriana and Massimiliano Fuksas © Fabio Lovino



“The idea springs from the world of illusions, the challenge of transforming a two-dimensional element into multiplying endless volumes” Doriana and Massimiliano Fuksas say regarding the new collections Chantal and Charlotte designed for Slamp in 2015. Studio Fuksas, with more than 600 projects completed – included the latest Shenzhen Bao'an International Airport - is one of the most outstanding international architectural firm in the world.

“L'idea nasce dal mondo dell'illusione, dalla sfida di trasformare un elemento bidimensionale in volumi che si moltiplicano all'infinito”, raccontano Doriana e Massimiliano Fuksas rispetto alle nuove collezioni Charlotte e Chantal disegnate per Slamp nel 2015. Lo studio Fuksas, con all'attivo oltre 600 progetti - tra cui il recente Shenzhen Bao'an International Airport - è uno dei più affermati studi internazionali di architettura nel mondo.

↑ Chantal collection by Doriana and Massimiliano Fuksas.

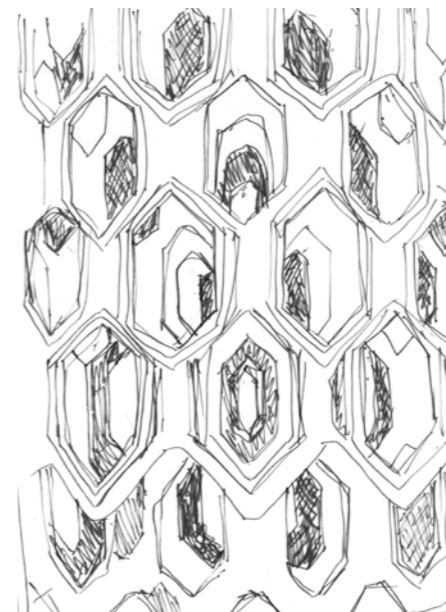
↑ Shenzhen Bao'an International Airport © Leonardo Finotti.

“The effect we wanted to achieve is a light reminiscent of waves chasing each other and the transparency of the moment when they thin out, and dematerialise, returning asinfinite illuminated drops”.

“L'effetto che volevamo ottenere è quello della luce trasmessa dal rincorrersi delle onde e la trasparenza del momento in cui si assottigliano, si dematerializzano rinviando interminabili gocce luminose”.



↑ Shenzhen Bao'an International Airport by Massimiliano and Doriana Fuksas. © Archivio Fuksas.



Zaha HADID



Architectural and dynamic projects builds, perfectly integrated with natural topography, are the expression of over thirty years of revolutionary exploration and research in the interrelated fields of urbanism, architecture and design of Zaha Hadid, winner of the Pritzker Architecture Prize in 2004. The Archistar, included in the TIME list of the “100 Most Influential People in the World”, designs for Slamp

Opere architettoniche dinamiche e perfettamente integrate alla topografia naturale sono l'espressione degli oltre 30 anni di rivoluzionaria esplorazione nei settori correlati all'urbanistica, all'architettura e al design di Zaha Hadid, vincitrice nel 2004 del Pritzker Architecture Prize. L'archistar, inserita dal TIME nell'elenco delle “100 persone più influenti al mondo”, disegna per Slamp Aria e Avia, due collezioni di lampade

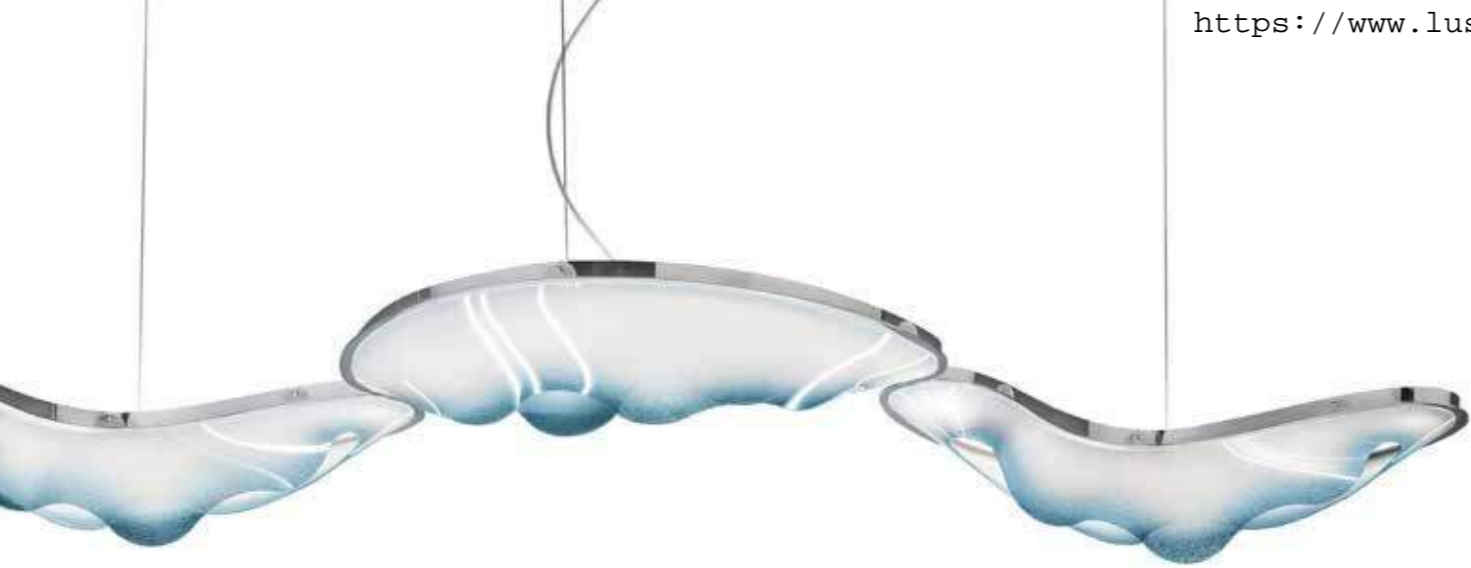
↑ Heydar Aliyev Centre – Baku, Azerbaijan © Helene Binet
↑ Elastic, Photography © Konstantin Eulenburg



↑ Dongdaemun Design Plaza, Seoul, Korea © Virgile Simon Bertrand

Aria and Avia, two suspension lamp collections that reproduce the majesty of great architectural works – such as the Dongdaemun Design Plaza of Seoul and the Heydar Aliyev Centre in Baku- modulating important volumes and state-of-the-art lighting technologies.

a sospensione che riproducono la maestosità delle grandi opere architettoniche - come il Dongdaemun Design Plaza di Seoul e il Heydar Aliyev Centre di Baku – modulando importanti volumi e tecnologie di illuminazione all'avanguardia.



↓ Upturning convention, in the 1980s Coates discovered an expressionistic architectural drawing style that captures the dynamics of space.



Nigel COATES

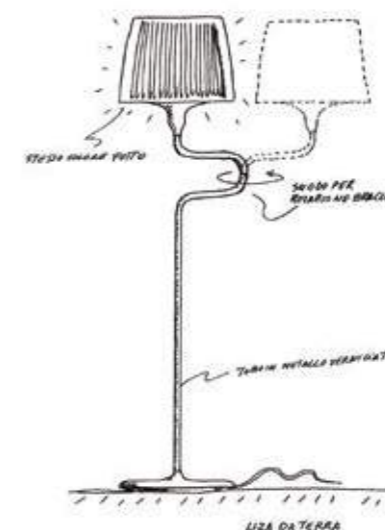
“In my mind the new Crocco suspension literally floats; its three half-moons unravel a ribbon of light that hangs in the air. This effect makes the most of Lentiflex as a luminescent, refractive material. Each element of this magical material is cut in such a way that when bent to fit the stainless steel frame, it bulges into a zoomorphic three-dimensionally outline. Continuous LED strips hidden along the edges ensure an even, upward light. Just one Crocco suspension is enough to make a sculptural statement, but when multiplied they can be tailored into a highly individual suspended art piece”.

“Nella mia mente la nuova sospensione Crocco fluttua nel vero senso della parola, le sue tre mezzelune ricreano un nastro di luce sospeso in aria. Questo effetto è dovuto al massimo sfruttamento del Lentiflex®, materiale luminescente e rifrangente. Ogni parte di questo magico materiale è tagliato in modo tale che, quando viene piegato e adattato alla struttura in acciaio inox, sporge in una linea zoomorfa tridimensionale. Le strisce continue di LED nascoste lungo i bordi assicurano una luce uniforme e rivolta verso l'alto. Una sola sospensione è sufficiente per creare una struttura scultorea, ma quando assemblate – a gusto personale - diventano un pezzo d'arte sospeso”.



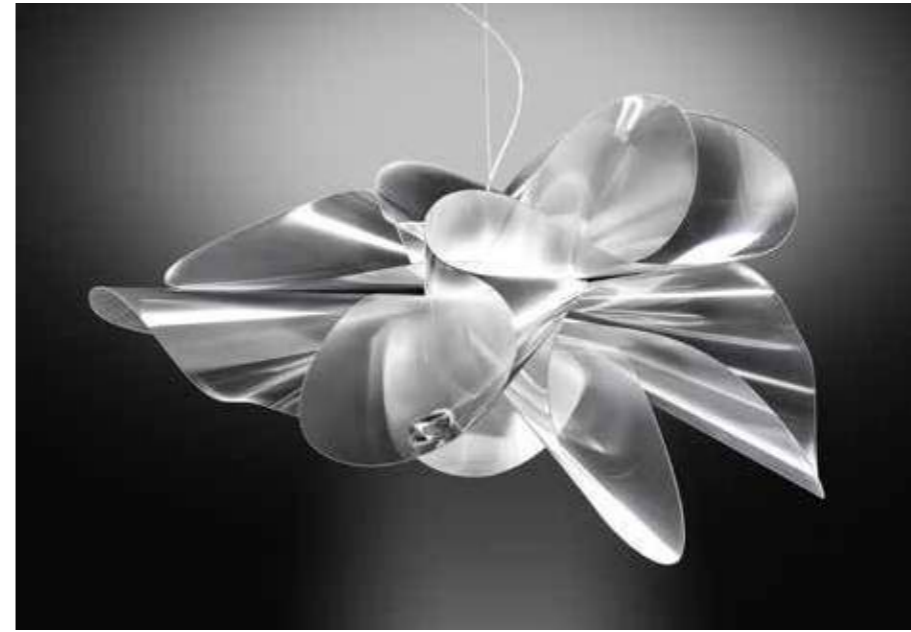
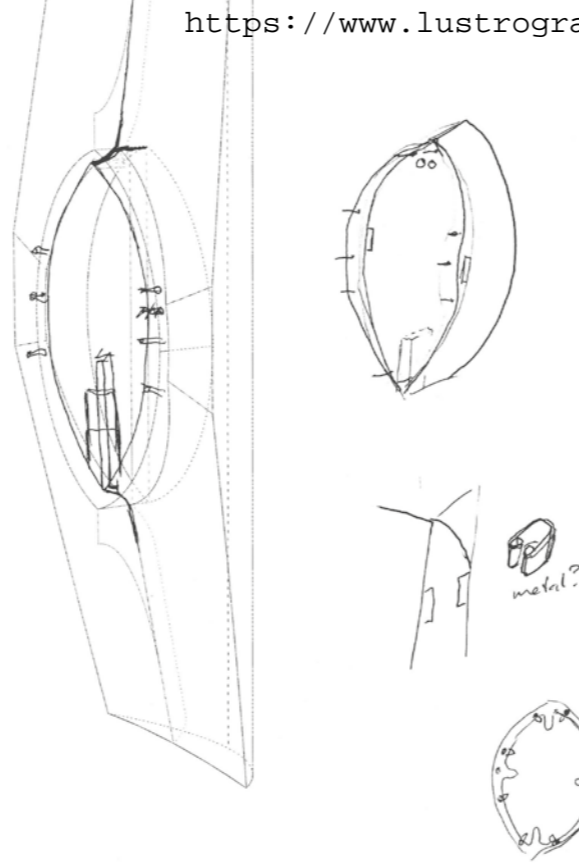
“When tackling a project for Slamp, it is the material which commands the highest challenge of the planning. In particular Lentiflex® produces refractions of light that have effects that range, according to the different orientations of the sheet, from kaleidoscopic to liquid, resembling the refractions of a crystal.” Elisa Giovannoni, Stefano's partner and wife, designed LIZA collection starting from the iconic crystal table lamp interpreted in a modern fashion. “The lamp is a decorative object for interior design, therefore the purpose of illumination is not its principal scope, but rather its ability to add distinction to the surrounding area”. A seductive collection that includes also an articulated floor lamp for reading.

“Nell'affrontare il progetto per Slamp il materiale è un imperativo progettuale con cui confrontarsi. In particolare il Lentiflex® produce delle rifrazioni della luce con degli effetti che vanno a seconda dell'orientamento del foglio dal caleidoscopico al liquido ricordando le rifrazioni del cristallo”. Elisa Giovannoni, moglie e partner di Stefano, disegna la collezione LIZA partendo dall' iconica lampada da tavolo in cristallo e reinterpretandola in chiave contemporanea. “La lampada è un oggetto decorativo per interni, quindi non è nella funzione di illuminare la sua principale valenza, ma piuttosto nella capacità di caratterizzare lo spazio che la circonda”. Una collezione seducente che comprende anche una piantana con snodo per la lettura.



↑ Liza collection, design by Elisa Giovannoni.





Adriano RACHELE

1 Étoile Suspension,
by Adriano Rachele.

Étoile recreates an explosion of light with a soft and dynamic form – Adriano Rachele says – an elegant dancing star, self-confident and able to fit in with any furnishings. A resolute lamp, a new way of illuminating with LED ...it recreates a theatrical light whose rays invoke that feeling experienced when next to the warm light of an old lamp. With Clizia, instead, a harmonic and romantic collection, I decided to appreciate craftsmanship and recreate the values of a fashion house”.

“Étoile ricrea un'esplosione di luce dalle forme morbide e dinamiche – racconta Adriano Rachele - un'elegante stella danzante sicura di sé e in sintonia con ogni arredo. Una lampada con carattere, un modo nuovo di illuminare con i LED...ricrea l'emozione di una luce calda di una vecchia lampadina. Con Clizia invece, una collezione armonica e romantica, ho voluto valorizzare l'aspetto artigianale e ricreare i valori di un atelier di moda”.



A natural optical illusion recreated in a wall lamp with a long shape that lends itself to multiple installations in linear geometries or free arrangements. “For the Mirage project –Manuel Wijffels says, the dutch designer who has already designed for Slamp the top seller Gemmy together with a team of designers – I started from a research to transform points of LED light into fascinating rays of light. The result is a variable light, which fills the spaces with its discreet presence, and is at the same time intriguing.

Un'illusione ottica naturale ricreata in un'appliche dalla forma longilinea che si presta ad allestimenti multipli in geometrie lineari o in disposizioni libere. “Per il progetto della Mirage - racconta Manuel Wijffels, designer olandese che ha già disegnato per Slamp il best seller Gemmy a quattro mani con altri progettisti – sono partito da una ricerca: trasformare i puntini dei LED in affascinanti raggi di luce. Il risultato è una luce mutevole, che riempie gli spazi con la sua presenza discreta e al tempo stesso intrigante”.

Manuel WIJFFELS



1 Clizia Fumé,
by Adriano Rachele.

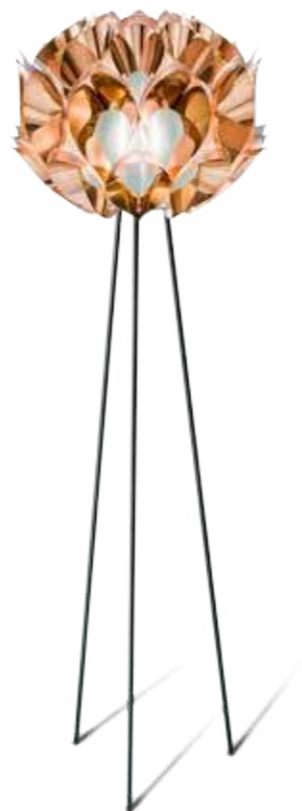


Zanini DE ZANINE



To design Flora I was inspired by a tropical plant which is abundant in Rio de Janeiro, the place where I live. I think that it's a lamp that transmits delicacy, functionality and...Brazilianity". Zanini de Zanine, growing up watching his father José Zanine Caldas working on architectural, sculptural and design projects, talks about his project for Slamp that won the Idea Design Award in 2014. "I wanted to make a "warm" lamp: a versatile lamp for the home as well as for public spaces".

“Per disegnare Flora mi sono ispirato a una pianta tropicale che è molto facile incontrare a Rio de Janeiro, la città dove vivo. Credo sia una lampada che trasmette delicatezza, funzionalità e...brasilianità”. Zanini De Zanine, cresciuto osservando il padre José Zanine Caldas lavorare a progetti di architettura, scultura e design, racconta il suo concept per Slamp che nel 2014 ha vinto l’Idea Design Award. “Ho voluto fare una lampada “calda” per gli spazi, una lampada anche versatile per le case, come per gli spazi pubblici”.



↑ Flora collection, by Zanini De Zanine



↑ La Lollo Copper Green, design by Lorenza Bozzoli.



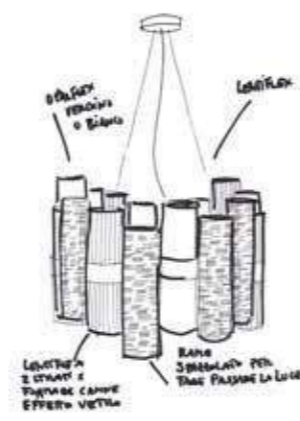
Lorenza BOZZOLI



← La Lollo photo setting, Slamp HQ.

Fashion first, then industrial designer with a high level of feminine romanticism, Lorenza Bozzoli, always fascinated by brass tube lamps, designed for Slamp “La Lollo”, a collection of stylish suspension lamps “which exude optimism” – as she herself declares. “A brass chandelier like that would weigh about 20 kg, but not with Slamp’s materials”. The diffuser is designed to fracture the light emitted by a thin circular source. One part illuminates the lamp itself, enhancing its decorative appearance, spreading itself softly through the surrounding area, and the other part is directed longitudinally by means of a game of reflections, providing a direct light on the furniture below.

Prima fashion poi industrial designer, con una rilevante quota di femminile romanticismo, Lorenza Bozzoli, da sempre affascinata dalle lampade con tubi in ottone, disegna per Slamp La Lollo, una collezione di sospensioni eleganti “che trasudano ottimismo” – come lei stessa racconta. “Un lampadario così in ottone peserebbe più o meno 20 chili, ma non con i materiali di Slamp”. Il diffusore è progettato per scomporre la luce emessa da una sottile sorgente circolare. Una parte illumina la lampada in sé valorizzandone l'aspetto decorativo e diffondendosi morbidamente nell'ambiente. Una parte è indirizzata longitudinalmente tramite un gioco di riflessioni per offrire una luce diretta all'arredamento sottostante.



PROGETTO ВЪОБЩЕНО

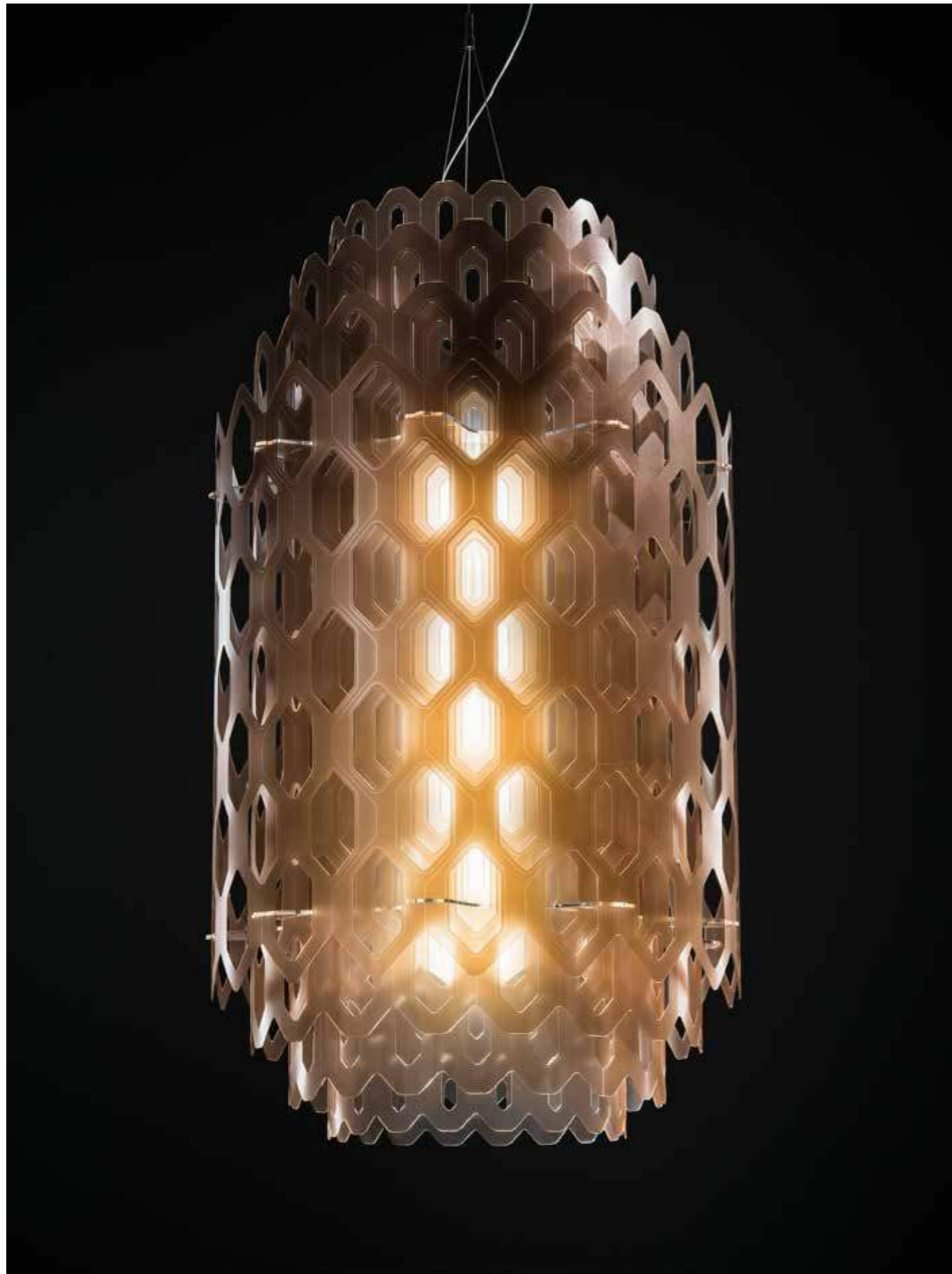
CHANTAL

BY DORIANA AND MASSIMILIANO FUKSAS

The idea springs from the world of illusions, the challenge of transforming a two-dimensional element into multiplying endless volumes. A light reminiscent of waves chasing each other and the transparency of the moment when they thin out, and dematerialise, returning as infinite drops of light.

L'idea nasce dal mondo dell'illusione, dalla sfida di trasformare un elemento bidimensionale in volumi che si moltiplicano all'infinito. Una luce che ricorda il rincorrersi delle onde e la trasparenza del momento in cui si assottigliano, si dematerializzano rinviando interminabili gocce luminose.









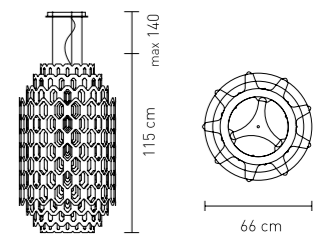
CHANTAL

design by Doriana and Massimiliano Fuksas

LARGE SUSPENSION

LED: 120W - 220V - 12.000 Lumen
2700 Kelvin

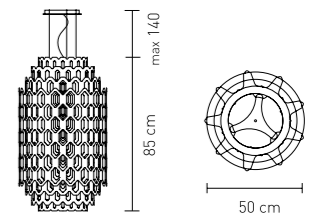
Made of: Cristalflex® / Lentiflex®



MEDIUM SUSPENSION

LED: 80W - 220V - 8.000 Lumen
2700 Kelvin

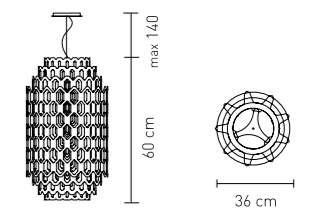
Made of: Cristalflex® / Lentiflex®



SMALL SUSPENSION

LED: 40W - 220V - 4.000 Lumen
2700 Kelvin

Made of: Cristalflex® / Lentiflex®



ORANGE



BLUE

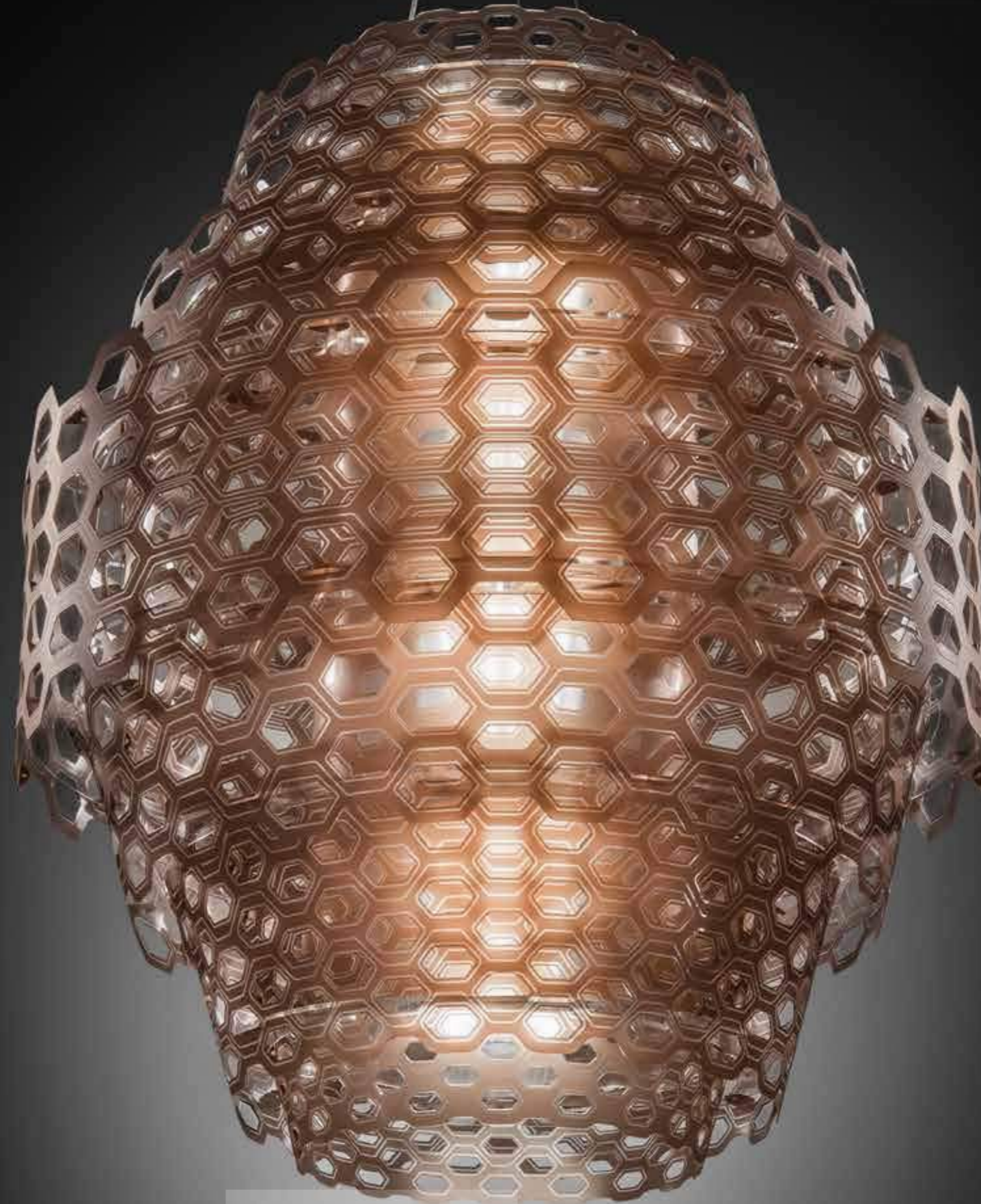


WHITE

List Ref: page 6

CHARLOTTE

BY DORIANA AND MASSIMILIANO FUKSAS





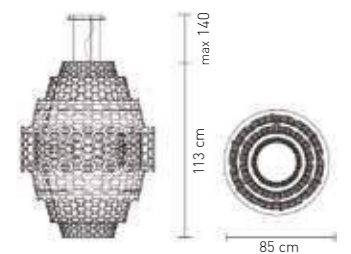
CHARLOTTE

design by Doriana and Massimiliano Fuksas

SUSPENSION

LED: 160W - 220V - 16.000 Lumen
2700 Kelvin

Made of: Cristalflex® / Lentiflex®



ORANGE



BLUE



WHITE

List Ref: page 7

ARIA *Transparent*

BY ZAHA HADID

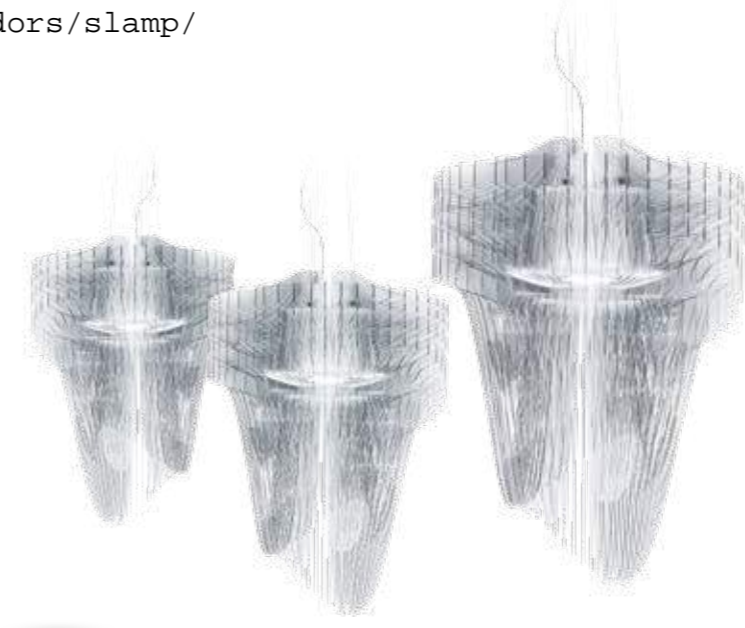
Zaha Hadid's dynamic and visionary architecture results in a volume that is apparently dematerialised, where illumination and lightness blend, defining natural design, becoming almost aquatic. 50 transparent surfaces, encountering LED lights positioned on their axis, take on a texture and enlighten the space with a vibrant atmosphere.

L'architettura dinamica e visionaria di Zaha Hadid si traduce in un volume apparentemente smaterializzato, in cui luce e leggerezza si avvolgono definendo un design naturale, quasi acquatico. 50 superfici trasparenti, incontrando la luce dei LED posizionati sul loro asse, prendono consistenza e accendono lo spazio di un'atmosfera vibrante.







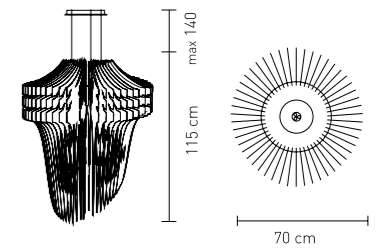


ARIA *Transparent* design by Zaha Hadid

LARGE SUSPENSION

LED: 76W - 220V - 10.000 Lumen
2700 Kelvin

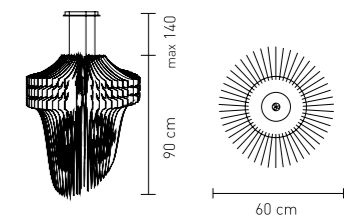
Made of: Cristalflex® / Lentiflex®



MEDIUM SUSPENSION

LED: 38W - 220V - 5.000 Lumen
2700 Kelvin

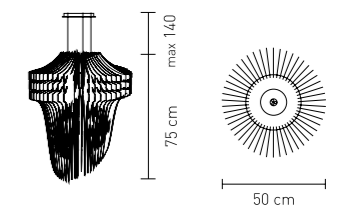
Made of: Cristalflex® / Lentiflex®



SMALL SUSPENSION

LED: 38W - 220V - 5.000 Lumen
2700 Kelvin

Made of: Cristalflex® / Lentiflex®



TRANSPARENT

List Ref: page 10

ARIA

BY ZAHA HADID



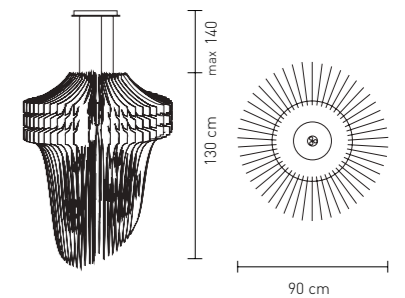
ARIA design by Zaha Hadid

SUSPENSION

Bulbs E27:

- 6 X 8W - LED Filament
- + 1 X 16W - Spot LED or
- 6 X 52W max - Halogen
- + 1 X 100W - Spot Halogen

Made of: Cristalflex® / Lentiflex®



BLACK SHADE

List Ref: page 11

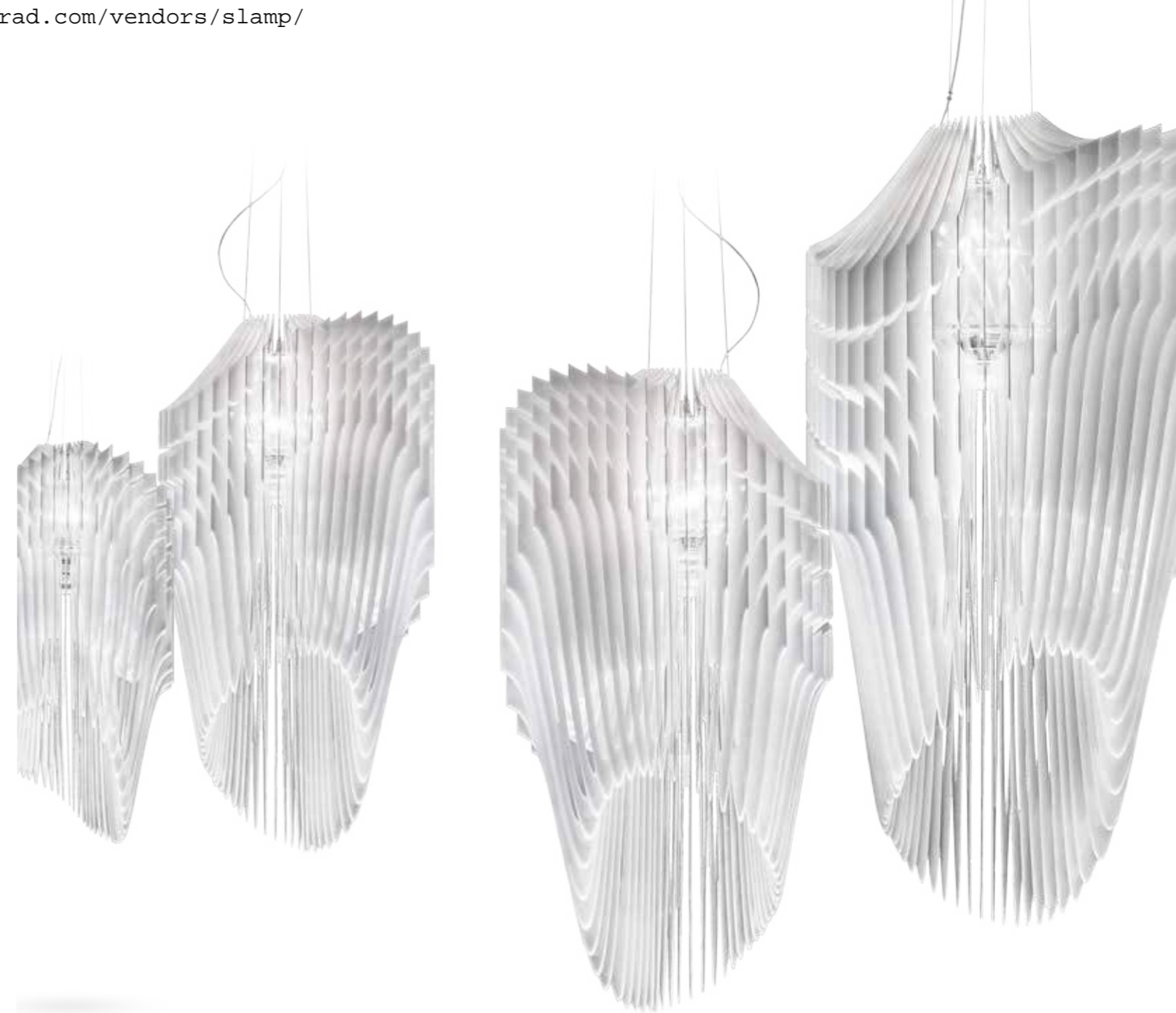
AVIA

BY ZAHA HADID

Fluid and dynamic, Avia combines the majesty of great architecture with a lamp for day-to-day use, perfectly integrating large volumes and advanced lighting techniques and technologies. 50 different layers of polycarbonate create a perfect architecture that surrounds the light source and transforms the light source into sculpture to be admired.

Fluida e dinamica, Avia unisce la maestosità delle grandi opere architettoniche a una lampada di utilizzo quotidiano, integrando alla perfezione importanti volumi a tecniche e tecnologie d'illuminazione all'avanguardia. 50 diversi layers di policarbonato creano una perfetta architettura che avvolge la sorgente luminosa e la trasformano da fonte di luce a scultura da ammirare





AVIA WHITE COLLECTION



AVIA

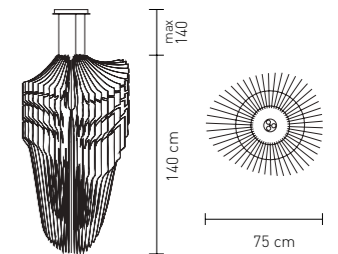
 design by Zaha Hadid

EXTRA LARGE SUSPENSION

Bulbs E27:

- 6 X 8W - LED Filament
- + 1 X 16W - Spot LED or
- 6 X 52W max - Halogen
- + 1 X 100W - Spot Halogen

Made of: Polycarbonate / Lentiflex®

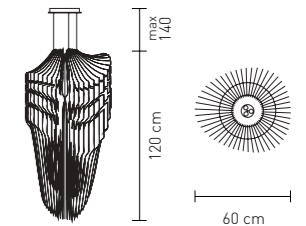


LARGE SUSPENSION

Bulbs E27:

- 4 X 8W - LED Filament
- + 1 X 16W - Spot LED or
- 4 X 52W max - Halogen
- + 1 X 100W - Spot Halogen

Made of: Polycarbonate / Lentiflex®

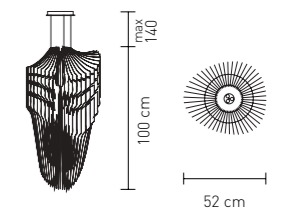


MEDIUM SUSPENSION

Bulbs E27:

- 3 X 8W - LED Filament
- + 1 X 11W - Spot LED or
- 3 X 52W max - Halogen
- + 1 X 100W - Spot Halogen

Made of: Polycarbonate / Lentiflex®

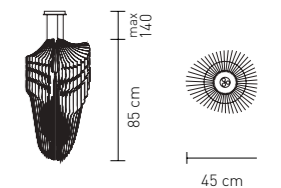


SMALL SUSPENSION

Bulbs E27:

- 2 X 8W - LED Filament
- + 1 X 11W - Spot LED or
- 2 X 52W max - Halogen
- + 1 X 100W - Spot Halogen

Made of: Polycarbonate / Lentiflex®



BLACK WHITE

List Ref: page 12

CLIZIA *Fumé*

BY ADRIANO RACHELE

Just as a cloud captures sunlight and irradiates iridescent reflections, Clizia brings back to environment the romantic glow of the early hours of dawn. Regular shapes, embedded in a perfect balance of transparencies and reflections create a design that appears chaotic, but in reality is naturally harmonious.

Proprio come una nuvola cattura la luce del sole e la carica di riflessi cangianti, Clizia riporta nell'ambiente il romantico chiarore delle prime ore del giorno. Forme regolari incastrate in un perfetto equilibrio di trasparenze e riflessi compongono un design all'apparenza caotico, eppure naturalmente armonico.





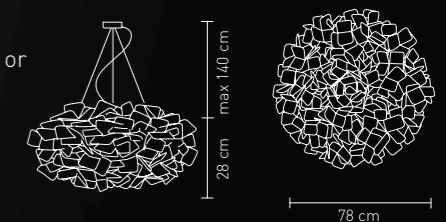
CLIZIA *Fumé* design by Adriano Rachele

LARGE SUSPENSION

Bulbs E27:
4 X 8W - LED Filament or
4 X 20W - FBT

Made of: Cristalflex Fumé®,
Lentiflex®

With: MagneticSystem®

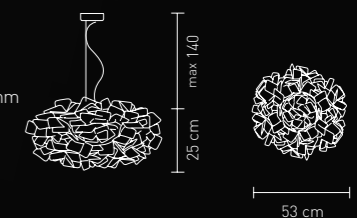


MEDIUM SUSPENSION

Bulbs E27:
2 X 8W - LED Filament or
2 X 20W - FBT - max length 115 mm

Made of: Cristalflex Fumé®,
Lentiflex®

With: MagneticSystem®



List Ref: page 16



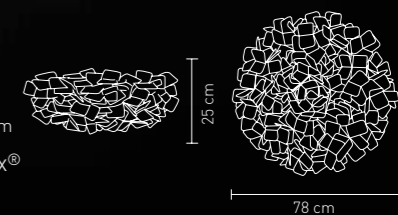
CLIZIA *Fumé* design by Adriano Rachele

LARGE CEILING / WALL LAMP

Bulbs E27:
3 X 8W - LED Filament or
3 X 20W - FBT - max length 105 mm

Made of: Cristalflex Fumé® /Lentiflex®

With: MagneticSystem®

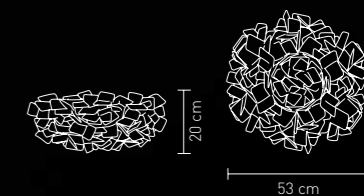


MEDIUM CEILING / WALL LAMP

Bulbs E27:
2 X 8W - LED Filament or
2 X 20W - FBT - max length 115 mm

Made of: Cristalflex Fumé® /Lentiflex®

With: MagneticSystem®

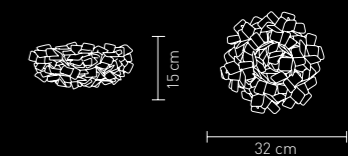


MINI CEILING / WALL LAMP

Bulbs E14:
1 X 4W - LED Filament or
1 X 11W - FBT - max length 110 mm

Made of: Cristalflex Fumé® /Lentiflex®

With: MagneticSystem®



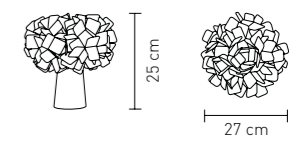
List Ref: page 17



CLIZIA *Fumé* design by Adriano Rachele

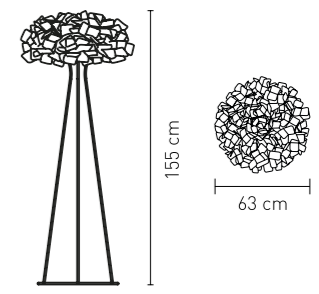
TABLE LAMP

Bulbs E14:
1 X 4W - LED Filament or
1 X 11W - FBT - max length 100 mm
Made of: Cristalflex Fumé® / Lentiflex®
With: MagneticSystem®
Coloured Steel Base



FLOOR LAMP

Bulbs E27:
3 X 8W - LED Filament or
3 X 20W - FBT - max length 115 mm
Made of: Cristalflex Fumé® / Lentiflex®
With: MagneticSystem®
Coloured Steel Base and Stem



List Ref: pages 18,19



CLIZIA

BY ADRIANO RACHELE



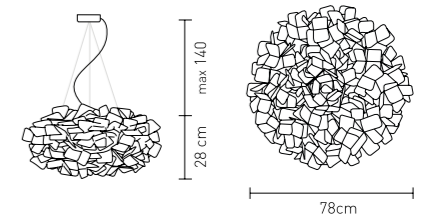
CLIZIA LARGE SUSPENSION.



CLIZIA design by Adriano Rachele

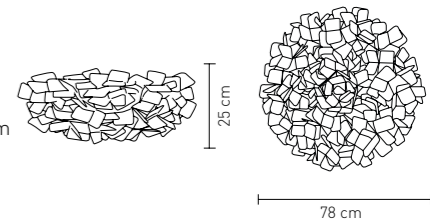
LARGE SUSPENSION

Bulbs E27:
4 X 8W - LED Filament or
4 X 20W - FBT
Made of: Opalflex®
With: MagneticSystem®



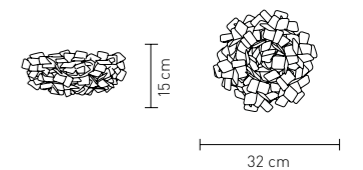
LARGE CEILING-WALL LAMP

Bulbs E27:
3 X 8W - LED Filament or
3 X 20W - FBT - max length 105 mm
Made of: Opalflex®
With: MagneticSystem®



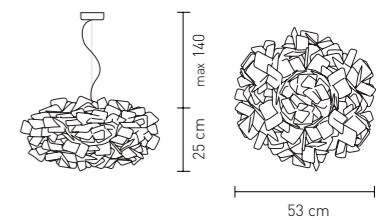
MINI CEILING-WALL LAMP

Bulbs E14:
1 X 4W - LED Filament or
1 X 11W - FBT - max length 110 mm
Made of: Opalflex®
With: MagneticSystem®



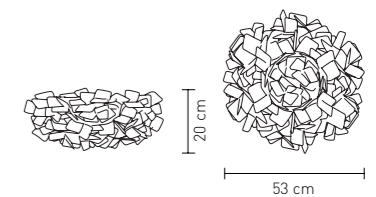
MEDIUM SUSPENSION

Bulbs E27:
2 X 8W - LED Filament or
2 X 20W - FBT - max length 115 mm
Made of: Opalflex®
With: MagneticSystem®

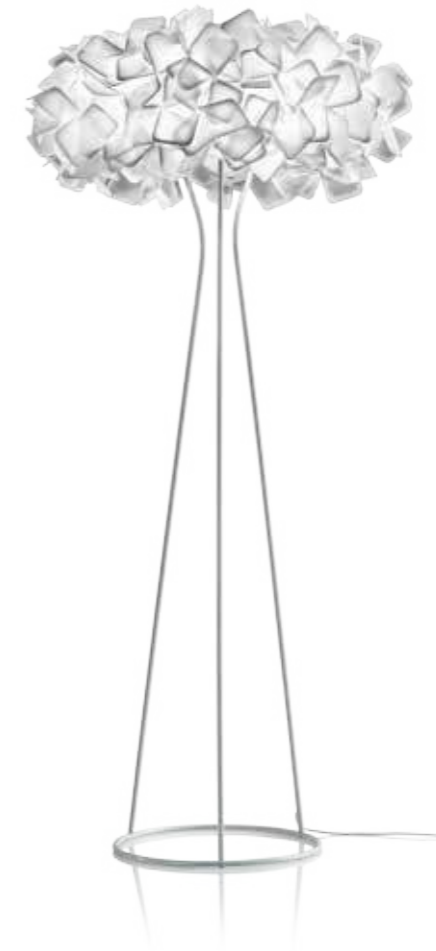


MEDIUM CEILING-WALL LAMP

Bulbs E27:
2 X 8W - LED Filament or
2 X 20W - FBT - max length 115 mm
Made of: Opalflex®
With: MagneticSystem®



List Ref: pages 16, 17



CLIZIA design by Adriano Rachele

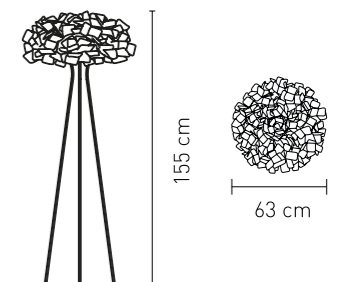
FLOOR LAMP

Bulbs E27:

- 3 X 8W - LED Filament or
- 3 X 20W - FBT - max length 115 mm

Made of: Opalflex®/Cristalflex Fumé®/
Lentiflex®

With: MagneticSystem®
Coloured Steel Base and Stem



List Ref: page 18



CLIZIA design by Adriano Rachele

TABLE LAMP

Bulbs E14:
1 X 4W - LED Filament or
1X 11W - FBT - max lenght 100 mm
Made of: Lentiflex®
With: MagneticSystem®
Coloured Steel Base



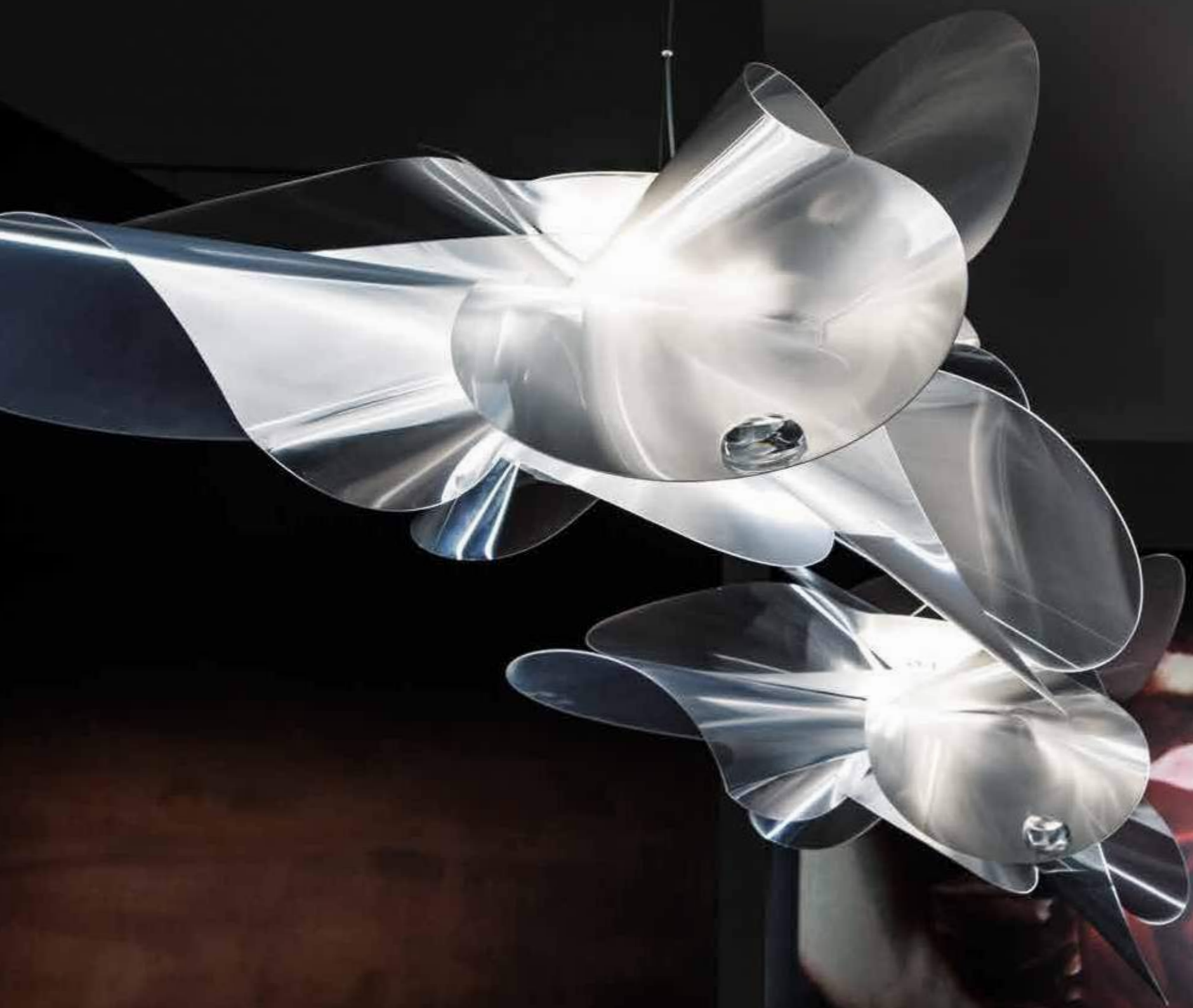
List Ref: page 19

ÉTOILE

BY ADRIANO RACHELE

It hovers lightly in the air with sublime elegance like a dancing star. Light is an accomplice of matter: together they start from the centre and reach the outermost surfaces propagating in the environment an explosion of energy and theatricality. The undisputed star of the scene, a perfect balance of asymmetrical forms, now also with a ceiling version with an ad hoc LED circuit.

Con leggerezza e sublime eleganza si libra nell'aria come una stella danzante. La luce è complice della materia: insieme partono dal cuore e raggiungono le superfici più esterne propagando nell'ambiente un'esplosione di energia e teatralità. Protagonista indiscussa della scena, in perfetto equilibrio su forme asimmetriche, ora anche in versione a soffitto con circuito LED realizzato ad hoc.





122 Étoile ceiling lamp, perspective view



ÉTOILE CEILING LAMP





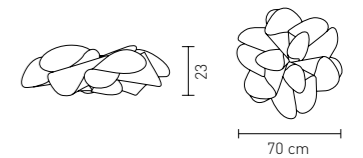
ÉTOILE

design by Adriano Rachele

CEILING-WALL LAMP

LED: 35W - 220V - 3500 Lumen
2700 Kelvin (warm white)
CRI 90

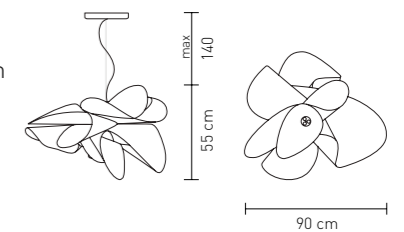
Made of: Lentiflex®
With: MagneticSystem®



LARGE SUSPENSION

LED: 38W - 220V - 5500 Lumen
2700 Kelvin (warm white)
CRI 90

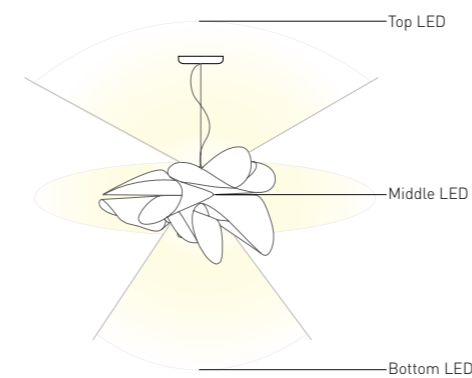
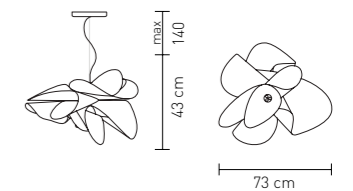
Made of: Lentiflex®
With: 3 light sources



SMALL SUSPENSION

LED: 38W - 220V - 5500 Lumen
2700 Kelvin (warm white)
CRI 90

Made of: Lentiflex®
With: 3 light sources



PRISMA

List Ref: page 22

LIZA

BY ELISA GIOVANNONI

The poetry of light meets the recollection of crystal lamps. A range of luminous presences, that extends from the table version with courtesy LED lights to the articulated floor lamps for reading. The unvaried element is the Lentiflex® shade that wraps one layer over the other, modelling the suspended pleats in colourful fabric, creating a kaleidoscope effect that floods the surroundings with reflections.

La poesia della luce incontra la memoria delle lampade in cristallo. Una gamma di presenze luminose che, dalla versione da tavolo con LED di cortesia, si amplia fino alla piantana con snodo per la lettura. Elemento invariante è il paralume in Lentiflex® che avvolge un layer nell'altro modellando le plissettature delle sospensioni in tessuto colorato e creando un effetto caleidoscopio che disegna l'ambiente di riflessi.





LIZA design by Elisa Giovannoni

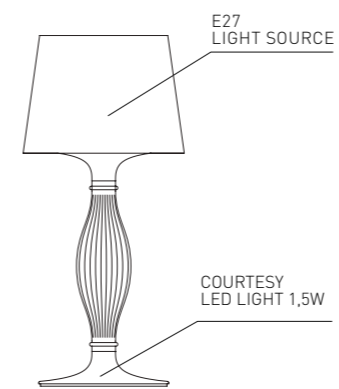
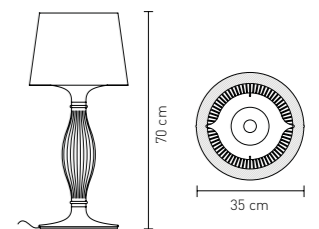
TABLE LAMP

HAT Bulbs E27:
1 X 8W - LED Filament or
1 X 70W max - Halogen

BASE LED:
1,5W - 220V - 100 Lumen

Made of: Lentiflex® / Polycarbonate

With: Two positions light switch



LIGHT SOURCES DISPOSITION



PRISMA YELLOW PURPLE

List Ref: page 26



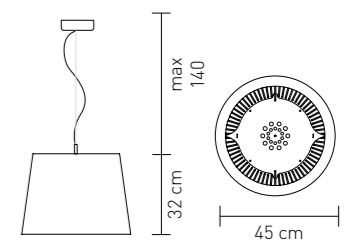


LIZA design by Elisa Giovannoni

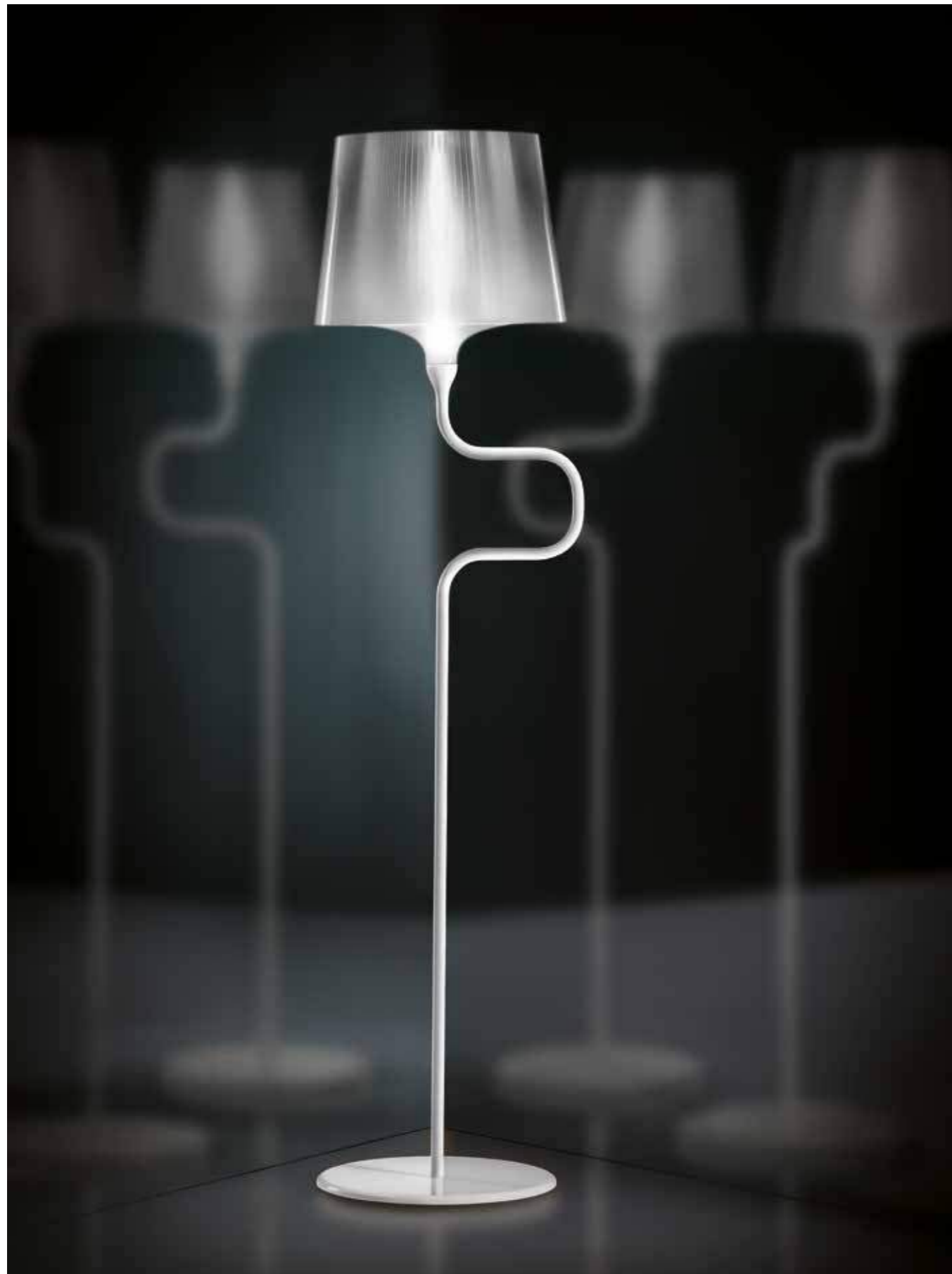
SUSPENSION

Bulbs E27:
1 X 8W - LED Filament or
1 X 70W max - Halogen

Made of: Lentiflex® / Polycarbonate



List Ref: page 27



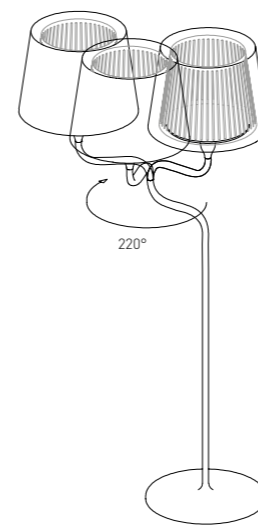
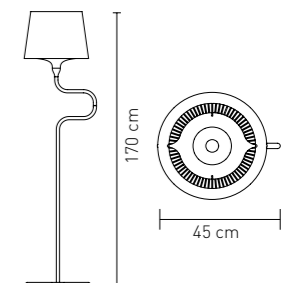
LIZA design by Elisa Giovannoni

FLOOR LAMP

Bulbs E27:
1 X 8W - LED Filament or
1 X 70W max - Halogen

Made of: Lentiflex®/ Polycarbonate

With: Coloured Steel Base and Stem



220° HAT ROTATION



PRISMA

YELLOW

PURPLE

List Ref: page 28

HUGO

BY SLAMP TEAM

Runs along the space from one end to the other, parallel to the floor, sideways, perpendicular. It customises the environment with a sinuous design and the softness of LED lights, diffused evenly by the Lentiflex®. Using a series in a longitudinal mode or in a free sequence is an individual choice, suitable for both a decorative project as well as for technical illumination.

Corre da un capo all'altro dello spazio, parallelo al pavimento, obliquo, perpendicolare. Personalizza l'ambiente con un disegno sinuoso e con la morbidezza della luce dei LED diffusa in maniera uniforme dal Lentiflex®. Disporre una serie in modo longitudinale o in sequenza libera è una scelta individuale, adatta tanto a un progetto decorativo quanto illuminotecnico.





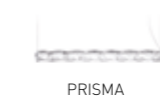
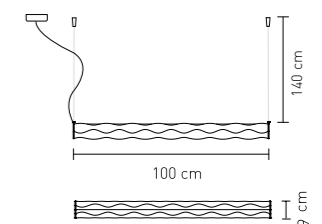


HUGO design by Slamp Team

SUSPENSION

LED: 30W - 220V - 3000 Lumen
2700 Kelvin

Made of: Lentiflex®



List Ref: page 32

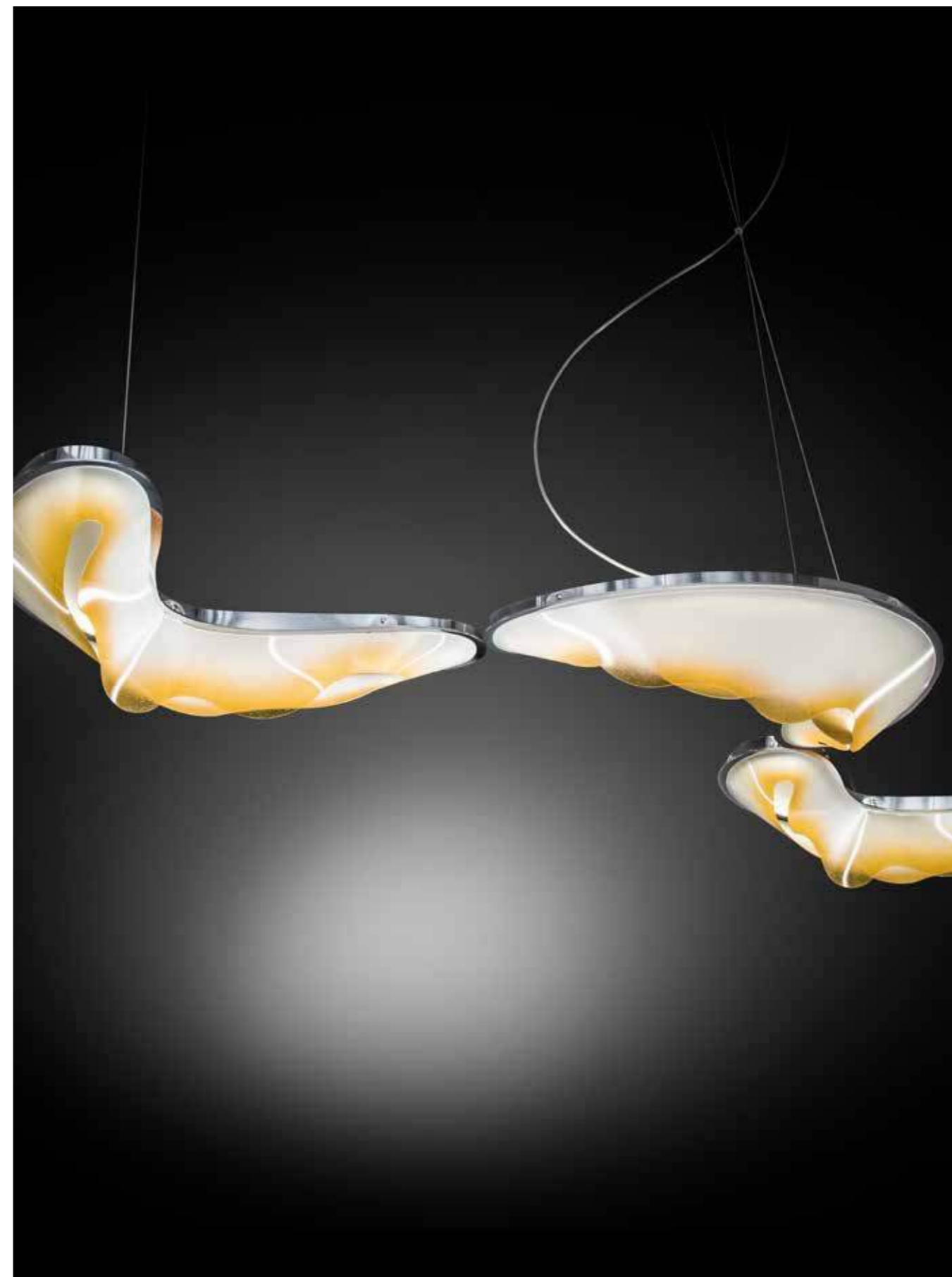
CROCCO

BY NIGEL COATES

It redesigns space, as multiple compositions of the wall lamp versions, or suspended in the new version in three modules that seems to float in the air. The brightness of Lentiflex®, the material used to design a zoomorphic form starting from the metal support, is increased by the nuance of the “morphing effect”, which makes the surface silky and colourful encountering LED light.

Ridisegna lo spazio, in composizioni multiple su parete nelle versioni applique, o nella nuova versione sospesa a tre moduli che sembra quasi galleggiare nell'aria. La luminosità del Lentiflex®, il materiale che dal supporto metallico disegna una forma zoomorfa, viene aumentata dalla sfumatura “morphing effect” che, incontrando la luce dei LED, rende la superficie setosa e colorata.





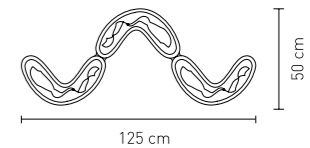


CROCCO design by Nigel Coates

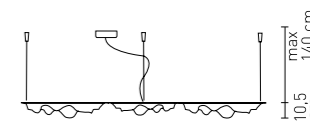
SUSPENSION

LED: 54W - 12V - 4200 Lumen

Made of: Lentiflex®



With: Stainless Steel Support



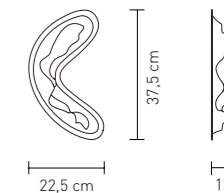
YELLOW GREY SKY

SMALL WALL LAMP

LED: 15W - 12V - 1200 Lumen
2700 Kelvin (warm white)

Made of: Lentiflex®

With: Stainless Steel support

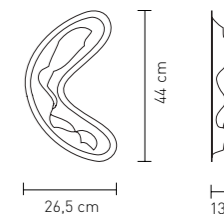


MEDIUM WALL LAMP

LED: 18W - 12V - 1400 Lumen
2700 Kelvin (warm white)

Made of: Lentiflex®

With: Stainless Steel support

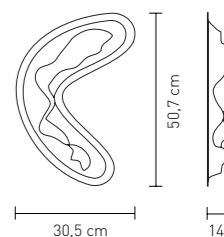


LARGE WALL LAMP

LED: 20W - 12V - 1600 Lumen
2700 Kelvin (warm white)

Made of: Lentiflex®

With: Stainless Steel support



YELLOW PINK GREY RED SAND SKY LEMON

List Ref: page 36

LA LOLLO

BY LORENZA BOZZOLI

It animates space with elegance and spontaneity, awakening memories of a past full of celebrity divas and limelight with its shape and chromes. LED illuminated cylinders are arranged at different heights around a central ring and alternate shades of precious metals in pastel colours with transparencies. The brushing of the metallisation leaves to the light the task of creating the suggested decorum.

Anima lo spazio con eleganza e spontaneità, risvegliando con forma e cromie i ricordi di una storia di dive e riflettori. I cilindri illuminati a LED sono disposti ad altezze variabili attorno a un anello centrale e alternano tonalità di metalli preziosi a trasparenze e colori pastello. La spazzolatura della metallizzazione lascia alla luce il compito di disegnare la suggestione del decoro.



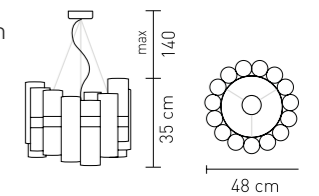




LA LOLLO design by Lorenza Bozzoli

SUSPENSION

LED: 28W - 12V - 1100 Lumen - 2700 Kelvin
Made of: Opalflex® / Cristalflex® /
Goldflex® / Steelflex® / Copperflex®
Lentiflex®



With: Ceiling Rose Matching Colour



GOLD - FUME



COPPER - GREEN



PEWTER - WHITE

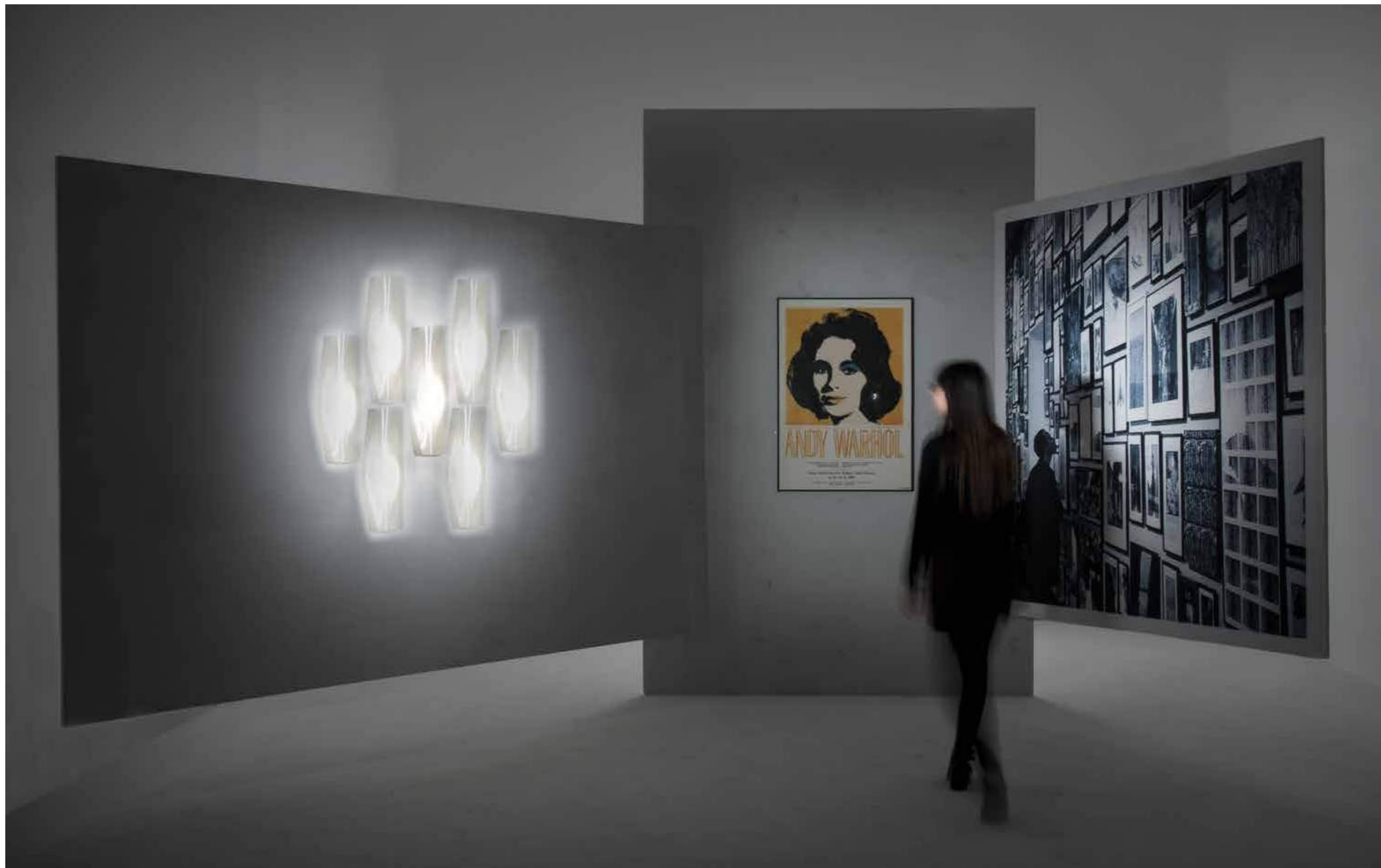
List Ref: page 53

MIRAGE

BY MANUEL WIJFFELS

A natural optical illusion recreated in a wall lamp with a long shape that lends itself to multiple installations in linear geometries or free arrangements. The light becomes decoration due to the LED crown that sparkles like a firework at the centre of the structure. The etymology and aesthetics of the prismatic surface of the diffuser recalls an affinity with glass and transparencies.

Un'illusione ottica naturale ricreata in un'appliche dalla forma longilinea che si presta ad allestimenti multipli in geometrie lineari o in disposizioni libere. La luce diventa decoro tramite la corolla di LED che brilla come un fuoco d'artificio al centro della struttura. La superficie prismatica del diffusore richiama, per etimologia ed estetica, l'affinità con il vetro e le trasparenze.





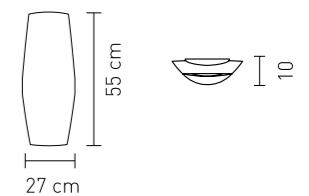
MIRAGE design by Manuel Wijffels

WALL LAMP

LED: 14W - 12V - 1100 Lumen
2700 Kelvin

Made of: Lentiflex®

With: Stainless Steel Support



PRISMA

List Ref: page 51

FLORA

BY ZANINI DE ZANINE

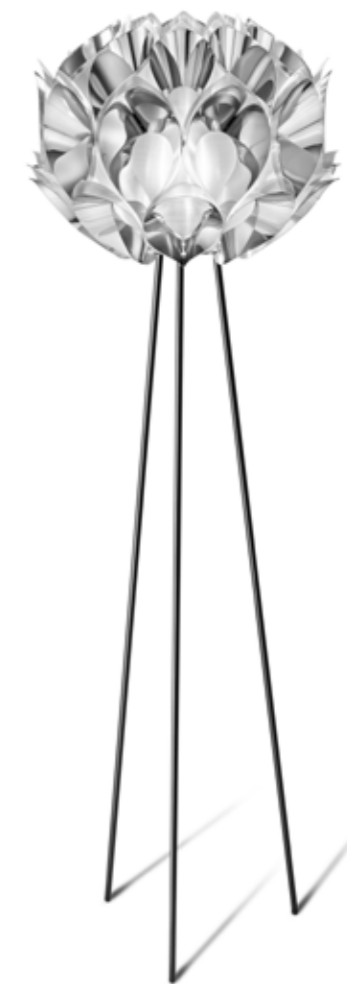
Inspired by the lush plants of the Brazilian jungle, Flora's design is structured around a central light source that transforms its petals into a fascinating crown of light. In Gold, Silver and Copper finishings, it generates sophisticated blazes of light in a game of reflections, mirroring the effects of the sun at its zenith over a field of ripe wheat.

Traendo ispirazione dalle forme della natura sudamericana, il design di Flora si articola intorno alla fonte luminosa centrale smerigliata che trasforma i petali in una affascinante corolla di luce. Nelle versioni Gold, Silver e Copper genera bagliori sofisticati in un gioco di riflessioni rubato all'effetto del sole allo zenith su un campo di grano maturo.





FLORA GOLD, SILVER AND COPPER



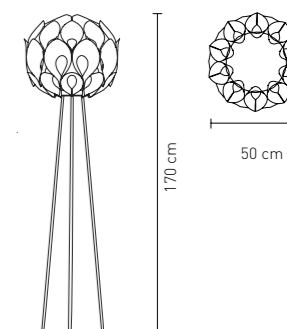
FLORA design by Zanini De Zanine

FLOOR LAMP

Bulbs E27:
3 X 8W - LED Filament or
3 X 20W - FBT Dimmable

Made of: Goldflex®/Steelflex®/Copperflex®
Methacrylate Sphere

With: MagneticSystem®
Handicraft-finished Sphere
Dimmer



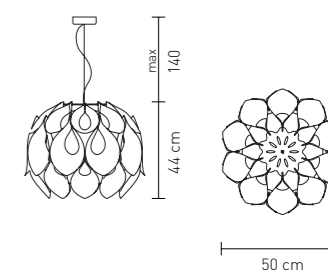
List Ref: page 41



FLORA design by Zanini De Zanine

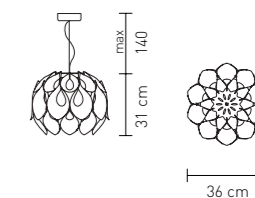
MEDIUM SUSPENSION

Bulbs E27:
 3 X 8W - LED Filament or
 3 X 42W max - Halogen
 Made of: Lentiflex®/ Methacrylate
 Copperflex®/Steelflex®/Goldflex®
 With: MagneticSystem®
 Handicraft-finished Sphere



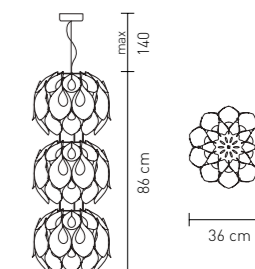
SMALL SUSPENSION

Bulbs E27:
 1 X 8W - LED Filament or
 1 X 42W max - Halogen
 Made of: Lentiflex®/ Methacrylate
 Copperflex®/Steelflex®/Goldflex®
 With: MagneticSystem®
 Handicraft-finished Sphere



TRIPLE SUSPENSION

Bulbs E14:
 3 X 4W - LED Filament or
 3 X 28W max - Halogen
 Made of: Lentiflex®/ Methacrylate
 Copperflex®/Steelflex®/Goldflex®
 Colours: White, Purple, Yellow, Blue



List Ref: page 40

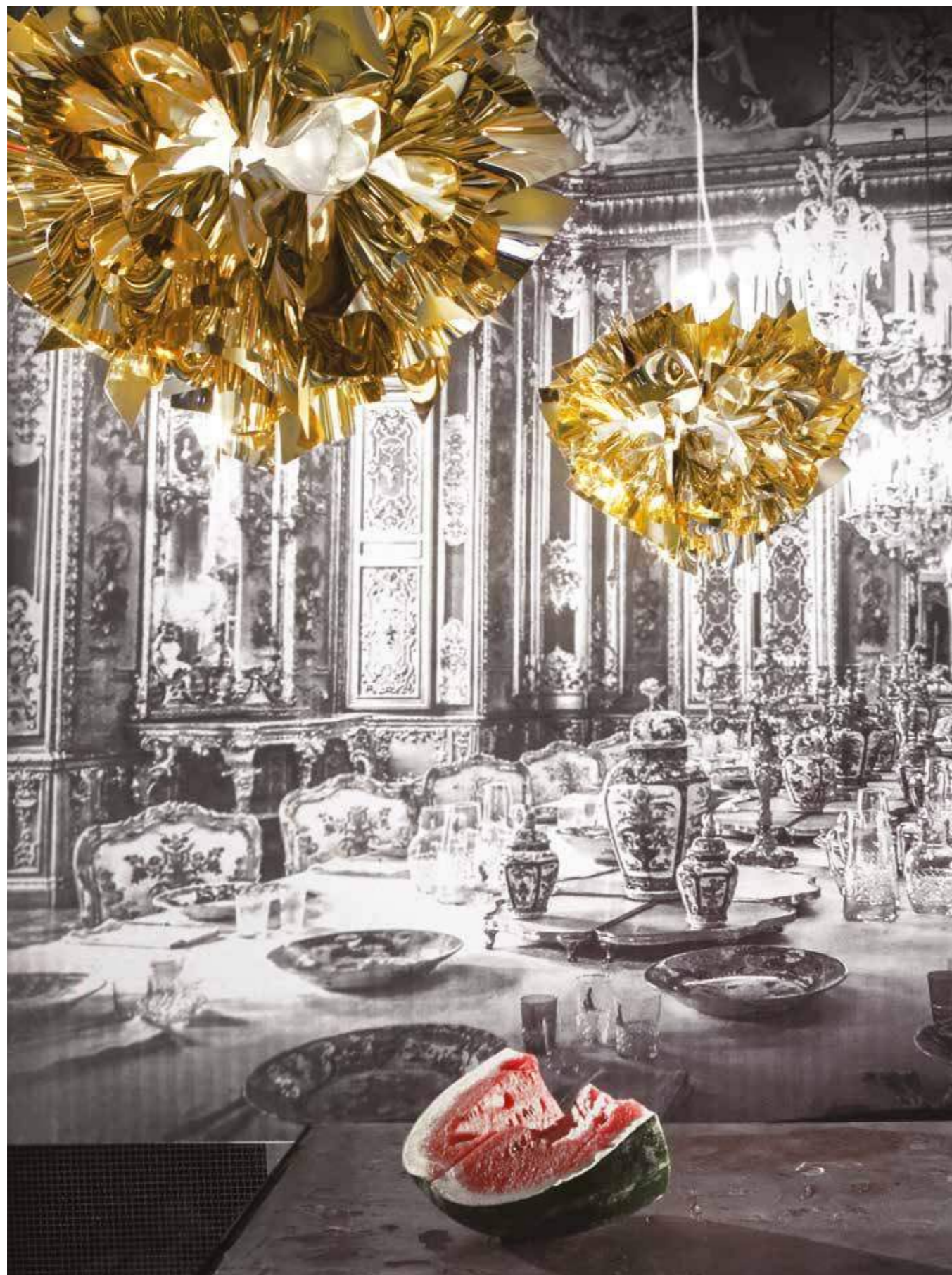
VELI

BY ADRIANO RACHELE

Inspired by the variegated world of fashion houses, where soft three-dimensional volumes are formed through folds, drapes and carvings, Veli is a glamorous and sophisticated collection of lamps. By means of a system of joints completed by hand, Veli is structured into a sinuous and elegant design, capable of enhancing all interiors; in the coloured shaded versions with a diffused light, intense in the transparent variants and lavishly full of reflections in the metallic finishes.

Ispirata al variegato mondo dell'haute couture dove con pieghe, panneggi e intagli si dà forma a morbidi volumi tridimensionali, Veli è una collezione di lampade glamour e sofisticate. Tramite un sistema di incastri eseguiti a mano, Veli si articola in un design sinuoso ed elegante capace di valorizzare ogni interior con luce diffusa nelle versioni con sfumatura colorata, intensa nelle varianti trasparenti e ricca di riflessi nelle finiture metallizzate.

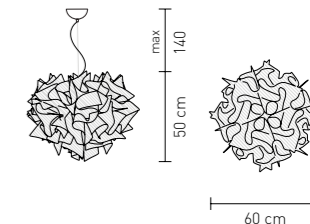




VELI *Gold, Silver and Copper* by Adriano Rachele

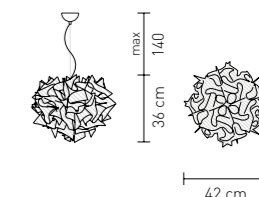
LARGE SUSPENSION

Bulbs E27:
4 X 8W - LED Filament or
4 X 20W max - FBT
Made of: Goldflex®/Steelflex®/Copperflex®
With: MagneticSystem®
Ceiling Rose Matching Colour



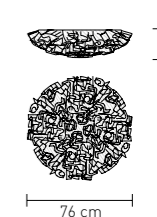
MEDIUM SUSPENSION

Bulbs E27:
2 X 8W - LED Filament or
2 X 20W max - FBT
(max length 135 mm)
Made of: Goldflex®/Steelflex®/Copperflex®
With: MagneticSystem®
Ceiling Rose Matching Colour



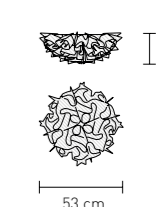
LARGE CEILING-WALL LAMP

Bulbs E27:
3 X 8W - LED Filament or
3 X 20W max - FBT
(max length 105 mm)
Made of: Goldflex®/Steelflex®/Copperflex®
With: MagneticSystem®



MEDIUM CEILING-WALL LAMP

Bulbs E27:
2 X 8W - LED Filament or
2 X 20W max - FBT
(max length 115 mm)
Made of: Goldflex®/Steelflex®/Copperflex®
With: MagneticSystem®



MINI CEILING-WALL LAMP

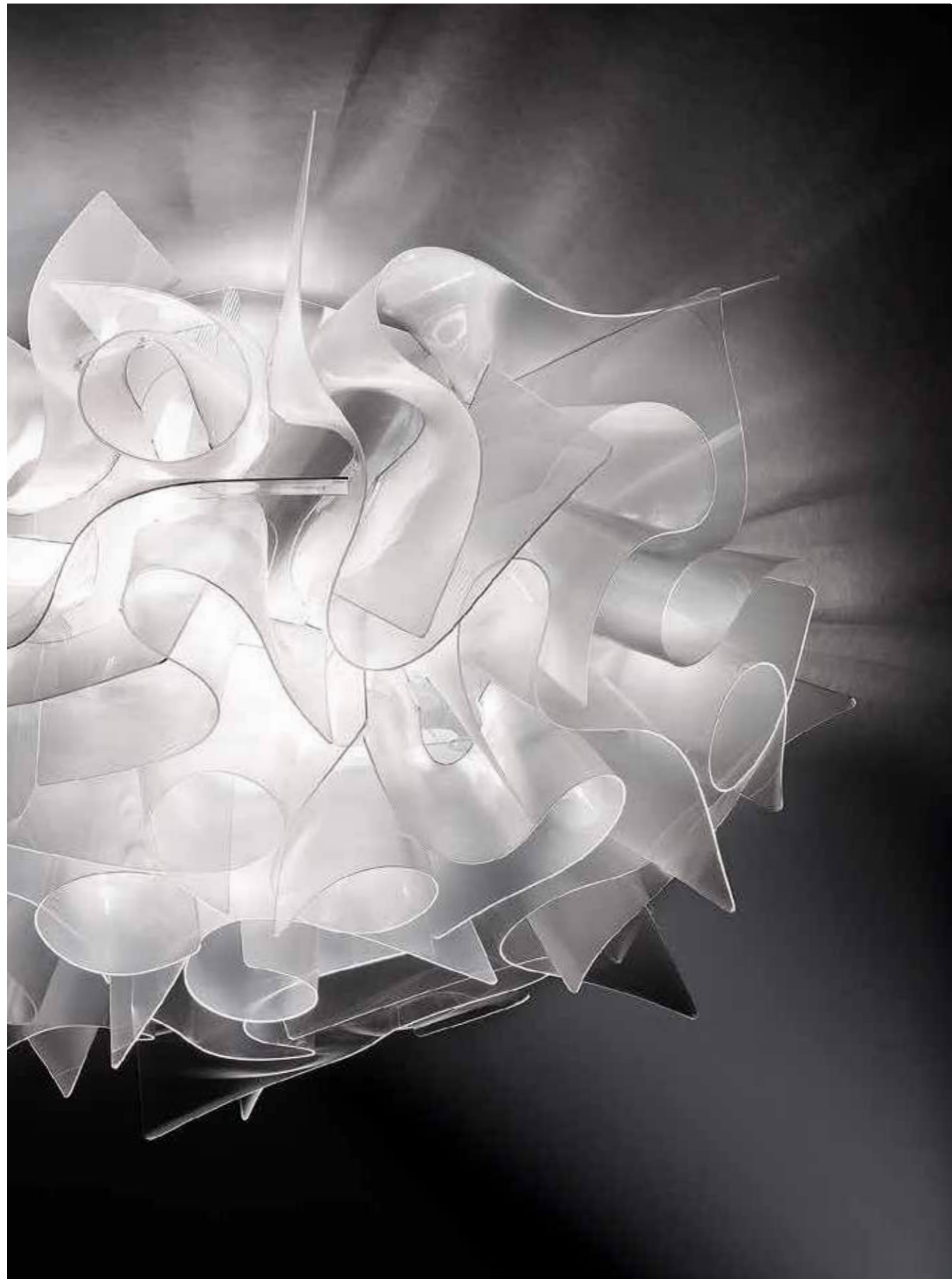
Bulbs E14:
1 X 4W - LED Filament or
1 X 11W max - FBT
(max length 110 mm)
Made of: Goldflex®/Steelflex®/Copperflex®
With: MagneticSystem®



List Ref: page 44



VELI COPPER, GOLD AND SILVER

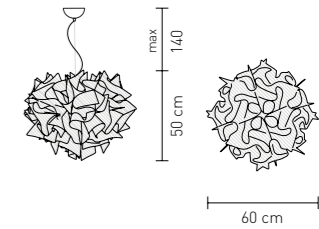


VELI PRISMA design by Adriano Rachele

LARGE SUSPENSION

Bulbs E27:
4 X 8W - LED Filament or
4 X 20W max - FBT

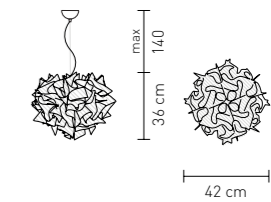
Made of: Prisma Lentiflex®
With: MagneticSystem®



MEDIUM SUSPENSION

Bulbs E27:
2 X 8W - LED Filament or
2 X 20W max - FBT
(max length 135 mm)

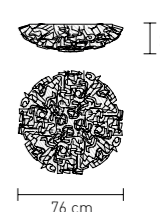
Made of: Prisma Lentiflex®
With: MagneticSystem®



LARGE CEILING-WALL LAMP

Bulbs E27:
3 X 8W - LED Filament or
3 X 20W max - FBT
(max length 105 mm)

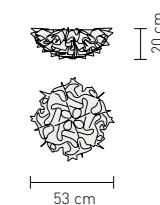
Made of: Prisma Lentiflex®
With: MagneticSystem®



MEDIUM CEILING-WALL LAMP

Bulbs E27:
2 X 8W - LED Filament or
2 X 20W max - FBT
(max length 115 mm)

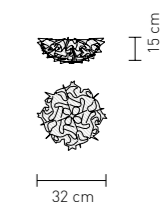
Made of: Prisma Lentiflex®
With: MagneticSystem®



MINI CEILING-WALL LAMP

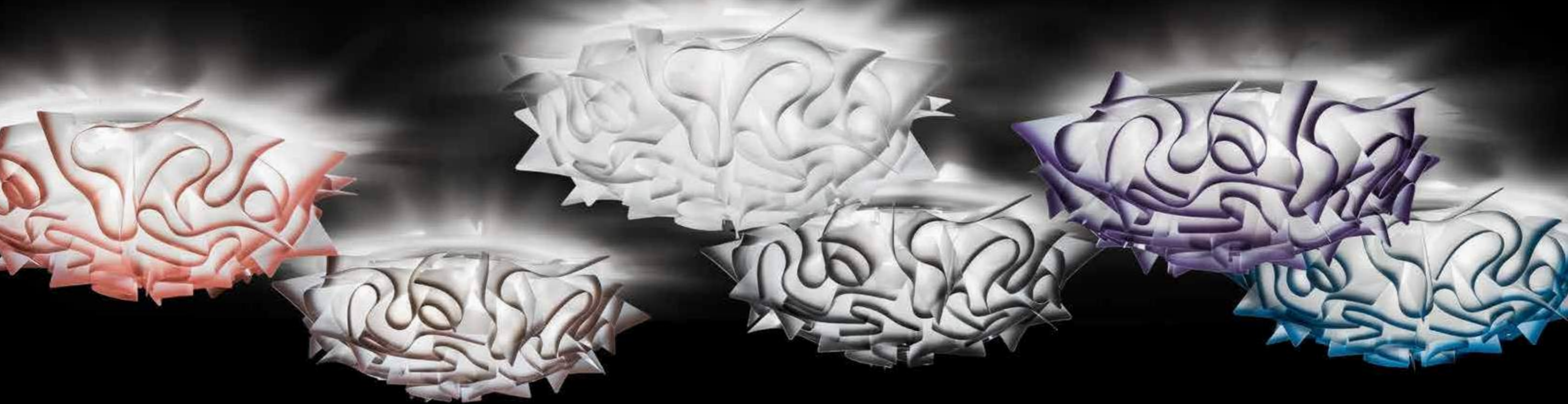
Bulbs E14:
1 X 4W - LED Filament or
1 X 11W max - FBT
(max length 110 mm)

Made of: Prisma Lentiflex®
With: MagneticSystem®



PRISMA

List Ref: page 44



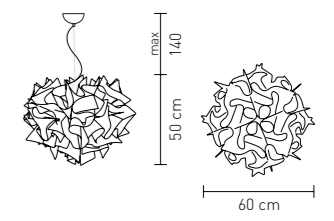


VELI design by Adriano Rachele



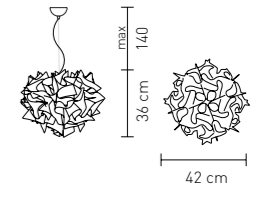
LARGE SUSPENSION

Bulbs E27:
4 X 8W - LED Filament or
4 X 20W max - FBT
Made of: Opalflex®
With: MagneticSystem®



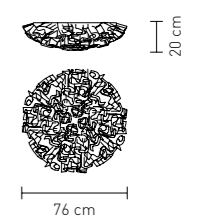
MEDIUM SUSPENSION

Bulbs E27:
2 X 8W - LED Filament or
2 X 20W max - FBT
(max length 135 mm)
Made of: Opalflex®
With: MagneticSystem®



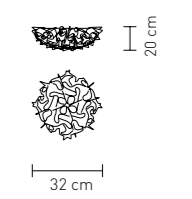
LARGE CEILING-WALL LAMP

Bulbs E27:
3 X 8W - LED Filament or
3 X 20W max - FBT
(max length 105 mm)
Made of: Opalflex®
With: MagneticSystem®



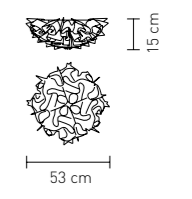
MINI CEILING-WALL LAMP

Bulbs E14:
1 X 4W - LED Filament or
1 X 11W max - FBT
(max length 110 mm)
Made of: Opalflex®
With: MagneticSystem®

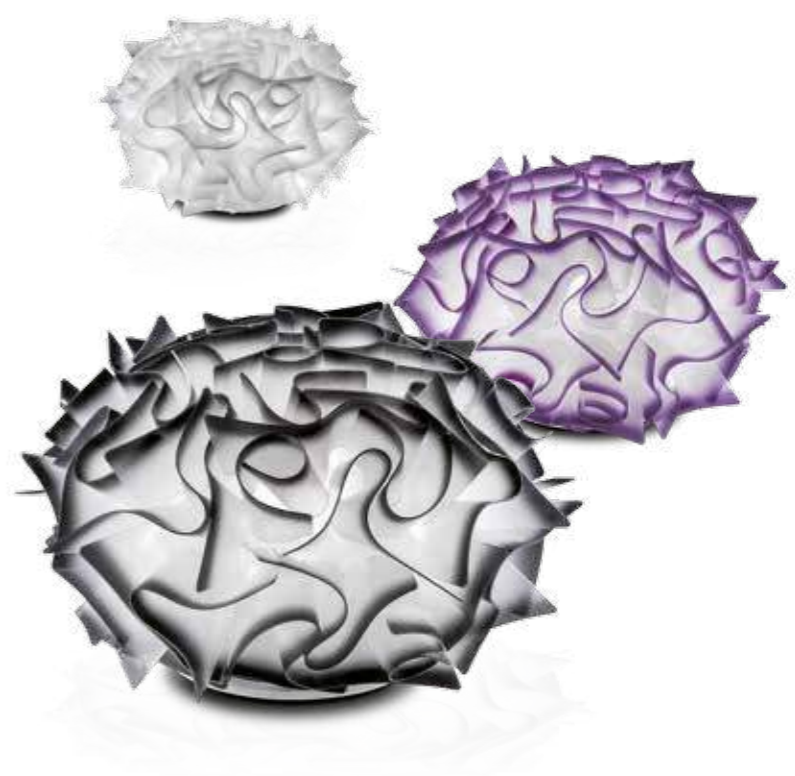


MEDIUM CEILING-WALL LAMP

Bulbs E27:
2 X 8W - LED Filament or
2 X 20W max - FBT
(max length 115 mm)
Made of: Opalflex®
With: MagneticSystem®



List Ref: pages 44

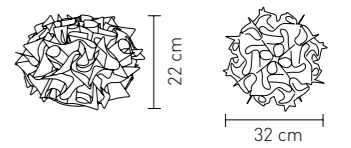


VELI TABLE design by Adriano Rachele

TABLE LAMP Ø 32

Bulbs E14:
1 X 4W LED Filament or
1 X 11W max - FBT
max lenght 110mm

Made of: Opalflex®
With: Metacrylate base



List Ref: page 49



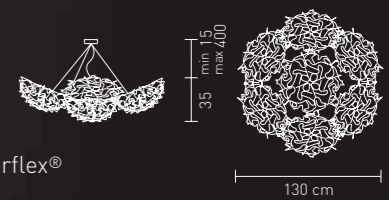
VELI 7 design by Adriano Rachele

CEILING-WALL LAMP

Bulbs E27:

9 X 8W LED Filament or
9 X 20W max FBT

Made of: Opalflex® / Lentiflex® / Copperflex®
Goldflex® / Steelflex®



List Ref: page 45

FIORELLA

BY NIGEL COATES

Realistic, embracing and suggestive, with its naturalistic details it transports the imagination to a floral world where the reality of small ruffled boxwood bushes meets the magic of the fresh figurativeness of Slamp's seductive expressive potential. The reflections of the petals play with light and are dispersed onto the walls of every type of interior, transforming the sequences of shadows and projected refractions into spells.

Realistica, avvolgente e suggestiva, con i suoi naturalistici dettagli conduce l'immaginazione verso un mondo floreale dove la realtà dei piccoli cespugli arruffati di bosso incontra la magia del fresco figurativismo e delle seducenti potenzialità espressive di Slamp. Riflessioni di petali giocano con la luce e si disperdono sulle pareti di ogni interior, trasformando in incantesimo le sequenze di ombre e rifrazioni proiettate.





FIGRELLA *Gold, Silver and Copper* design by Nigel Coates

MINI SUSPENSION

Bulbs E27:

- 1 X 8W LED Filament or
- 1 X 40W max - Halogen

Made of: Goldflex® / Steelflex® / Copperflex®

With: Ceiling Rose matching colour

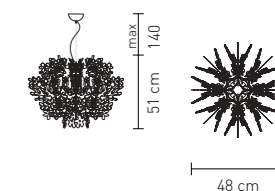


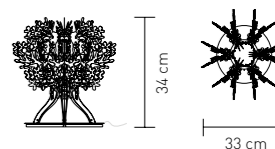
TABLE LAMP - FIGRELLINA

Bulbs E14:

- 1 X 4W LED Filament or
- 1 X 28W max - Halogen

Made of: Goldflex® / Steelflex® / Copperflex®

With: Bulb included
Base matching colour



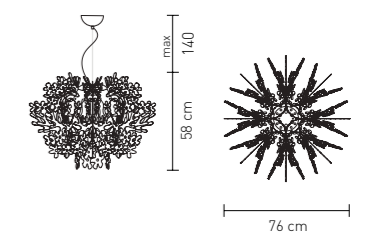
List Ref: page 56



FIORELLA design by Nigel Coates

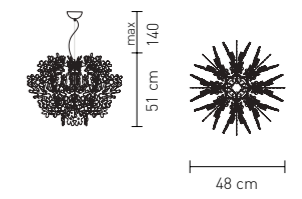
SUSPENSION

Bulbs E27:
1 X 8W LED Filament or
1 X 100W max - Halogen
Made of: Opalflex® / Cristalflex®



MINI SUSPENSION

Bulbs E27:
1 X 8W LED Filament or
1 X 40W max - Halogen
Made of: Opalflex® / Cristalflex®
Colours: White, Gold, Silver, Copper



MINI WALL LAMP

Bulbs E14:
1 X 4W LED Filament or
1 X 25W max - Halogen
Made of: Opalflex® / Cristalflex®
With: Stainless Steel support

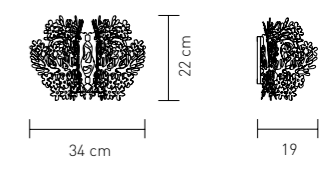
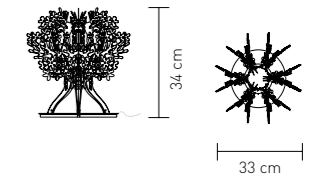


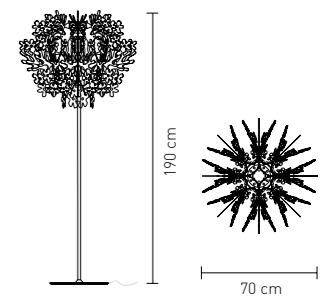
TABLE LAMP - FIORELLINA

Bulbs E14:
1 X 4W LED Filament or
1 X 28W max - Halogen
Made of: Opalflex® / Cristalflex®
With: Bulb included
Colours: White, Fumé, Gold, Silver, Copper



FLOOR LAMP

Bulbs E27:
1 X 8W LED Filament or
1 X 75W max - Halogen
Made of: Opalflex® / Cristalflex®
With: Stainless Steel base and stem



List Ref: page 56

BACH

BY FRANCESCO PARETTI

Slender, stately and refined, it gives off a sense of warmth and unexpected welcome. Light colours and different heights so as to embrace every interior, creating a poetically entrancing atmosphere. The elegant yet rigorous forms join the modern curves that follow perfectly the lines of each architectural environment.

Snella, statuarica, raffinata, sprigiona un senso di calore ed accoglienza inattesi. Colori chiari e altezze diverse per abbracciare ogni interior, creando un'atmosfera poeticamente avvolgente. Le eleganti ma rigorose forme si legano alle moderne curvature capaci di seguire perfettamente le linee di ogni ambiente architettonico.





BACH design by Francesco Piretti

SMALL TABLE LAMP

Bulbs E14:

1 X 4W LED Filament or
1 X 40W max - Halogen

Made of: Opalflex®

With: Stainless Steel base



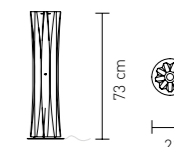
MEDIUM TABLE LAMP

Bulbs E27:

1 X 8W LED Filament or
1 X 60W max - Halogen

Made of: Opalflex®

With: Stainless Steel base



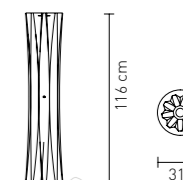
LARGE FLOOR LAMP

Bulbs E27:

2 X 8W LED Filament or
2 X 60W max - Halogen

Made of: Opalflex®

With: Stainless Steel base



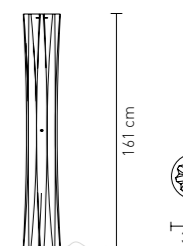
EXTRALARGE FLOOR LAMP

Bulbs E27:

3 X 8W LED Filament or
3 X 75W max - Halogen

Made of: Opalflex®

With: Stainless Steel base
Dimmer



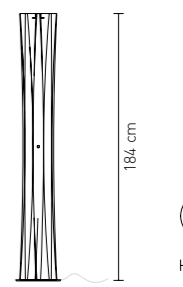
XXLARGE FLOOR LAMP

Bulbs E27:

3 X 8W LED Filament or
3 X 75W max - Halogen

Made of: Opalflex®

With: Stainless Steel base
Dimmer



WHITE GOLD

List Ref: page 58

GEMMY

BY RAGNISCO, WIJFFELS, CROCE, SPALLETTA

Contemporary, dynamic and versatile. Inspired by the precious gems of the desert, it wraps the light geometrically with its polyhedral facets and generates intriguing kaleidoscopic effects, capable of enriching every modern and refined interior with character.

Contemporanea, dinamica e versatile. La collezione ispirata alle preziose gemme desertiche, con le sue poliedriche sfaccettature, avvolge geometricamente la luce e genera intriganti effetti caleidoscopici, capaci di arricchire con carattere ogni interior dal gusto moderno e ricercato.





GEMMY PRISMA

design by Spalletta, Croce, Ragnisco, Wijffels

SUSPENSION

Bulbs E27:

1 X 8W LED Filament or
1 X 75W max - Halogen

Made of: Lentiflex®

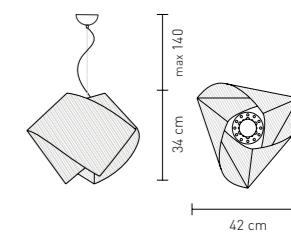


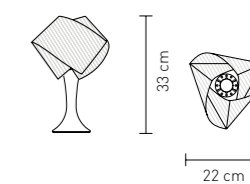
TABLE LAMP

Bulbs E14:

1 X 4W LED Filament or
1 X 40W max - Halogen

Made of: Lentiflex®

With: White Steel Base



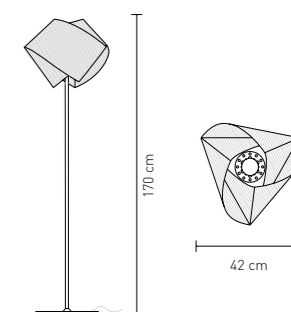
FLOOR LAMP

Bulbs E27:

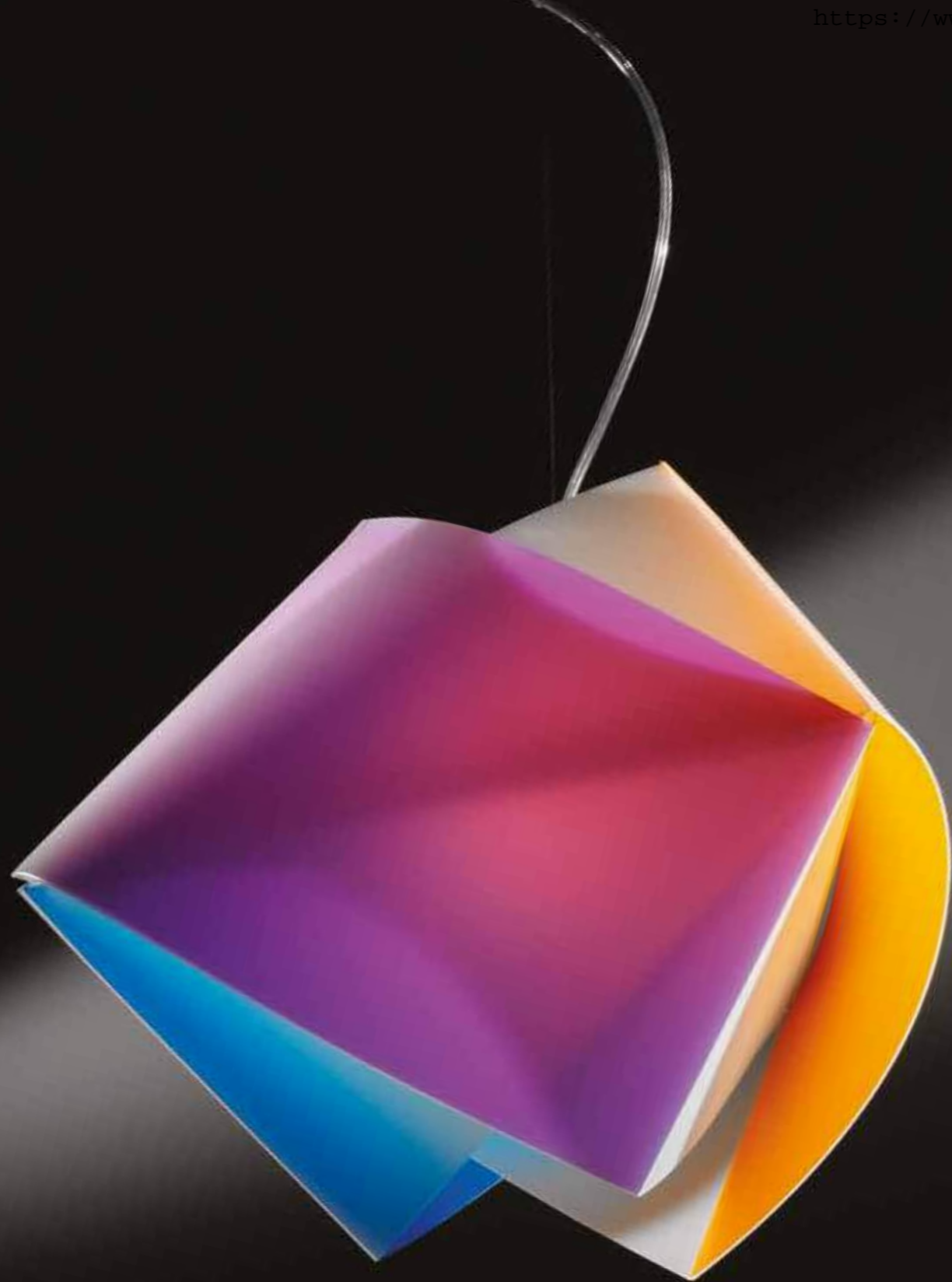
1 X 8W LED Filament or
1 X 75W max - Halogen

Made of: Lentiflex®

With: White Steel Base and Stem



List Ref: page 61



GEMMY design by Spalletta, Croce, Ragnisco, Wijffels

SUSPENSION

Bulbs E27:

1 X 8W LED Filament or
1 X 75W max - Halogen

Made of: Opalflex®

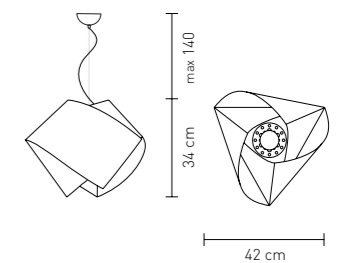


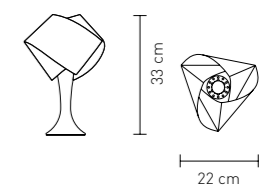
TABLE LAMP

Bulbs E14:

1 X 4W LED Filament or
1 X 40W max - Halogen

Made of: Opalflex®

With: White Steel Base



List Ref: page 60

CEREMONY

BY BRUNO RAINALDI

Like a necklace of pearls or the drape of a neckline, this lamp is a sumptuous homage to femininity at an impressive scale. Five light sources backlight swathes of techno-polymers; suitable as a feature in an entrance hall or staircase.

Suntuoso inno alla femminilità: evoca una gonna e un ballo, una collana di perle, il drappeggio di una scollatura. La luce delle 5 fonti luminose si diffonde tra le "collane" di tecnopolimeri donandole un forte impatto scenografico, una presenza imponente eppure leggera.





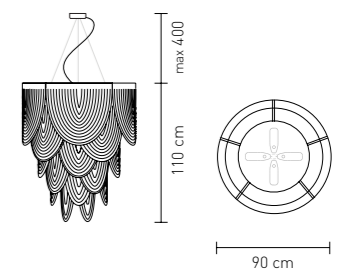
CEREMONY design by Bruno Rainaldi

Ø 90 SUSPENSION

Bulbs E27:

- 4 X 8W - LED Filament
- + 1 X 4W - GU10 Spot LED or
- 4 X 23W max FBT - max lenght 135 mm
- + 1 X 75W max - GU10 Halogen

Made of: Lentiflex® or Cristalflex Fumé® or Opalflex Porcelaine®

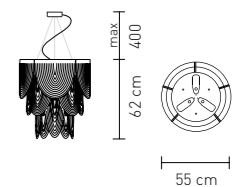


Ø 55 SUSPENSION

Bulbs E27:

- 3 X 8W - LED Filament
- + 1 X 4W - GU10 Spot LED or
- 3 X 23W max FBT - max lenght 115 mm
- + 1 X 75W max - GU10 Halogen

Made of: Lentiflex® or Cristalflex Fumé® or Opalflex Porcelaine®



List Ref: page 62

CACTUS

BY ADRIANO RACHELE

This iconic lamp combines geometry with the advanced technology of Lentiflex® to achieve irresistible sparkle and very suggestive prismatic reflections. In the smallest size, its customised packaging makes the lamp a perfect gift to be placed on every table or by the bedside.

Questa iconica lampada combina la geometria alla tecnologia all'avanguardia del Lentiflex®, che le dona uno sparkling irresistibile e riflessi prismatici molto suggestivi. Nelle misure più piccole, il suo packaging personalizzato la rende un perfetto regalo da porre su ogni tavolo o comodino.



CACTUS PRISMA design by Adriano Rachele

XS TABLE LAMP

Bulbs E14:
1 X 4W LED Filament or
1 X 28W max - Halogen

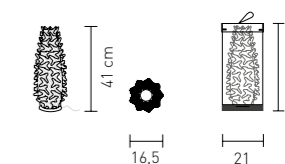


Made of: Lentiflex® / Stainless Steel base

With: Special Gift Pack
Bulb included

XM TABLE LAMP

Bulbs E14:
1 X 4W LED Filament or
1 X 28W max - Halogen

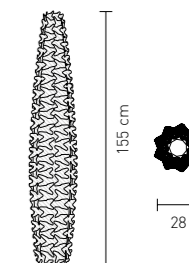


Made of: Lentiflex® / Stainless Steel base

With: Special Gift Pack
Bulb included

EXTRALARGE TABLE LAMP

Bulbs E27:
2 X 8W LED Filament or
2 X 75W max - Halogen



Made of: Lentiflex® / Stainless Steel base

With: Dimmer



PRISMA

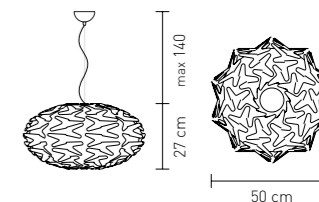
List Ref: page 63



CACTUS design by Adriano Rachele

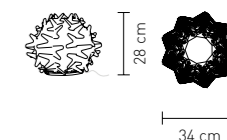
SUSPENSION

Bulbs E27:
1 X 8W LED Filament or
1 X 75W max - Halogen
Made of: Opalflex®



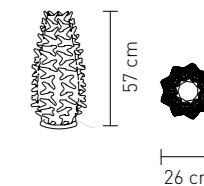
SMALL TABLE LAMP

Bulbs E14:
1 X 4W LED Filament or
1 X 11W FBT
Made of: Opalflex®
With: Stainless Steel base



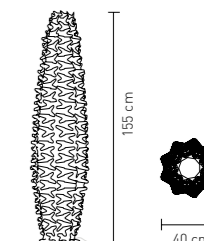
MEDIUM FLOOR-TABLE LAMP

Bulbs E14:
1 X 4W LED Filament or
1 X 11W FBT
Made of: Opalflex®
With: Stainless Steel base



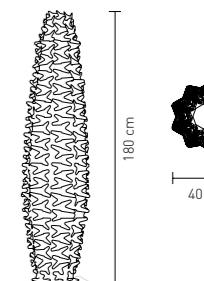
EXTRALARGE FLOOR LAMP

Bulbs E27:
2 X 8W LED Filament or
2 X 24W FBT
Made of: Opalflex®
With: Stainless Steel base



XXLARGE FLOOR LAMP

Bulbs E27:
2 X 8W LED Filament or
2 X 24W FBT
Made of: Opalflex®
With: Stainless Steel base



GOLD

List Ref: page 64

MEDUSA

BY NIGEL COATES

It moves with fluidity and grace, a protector and guardian of its surroundings. An elegant and sophisticated design, embellished by 40 transparent crystal pendants with iridescent reflections, also in the new pewter colour, which donates a mysterious and seductive aspect to those interiors in need of a touch of style and magnificence.

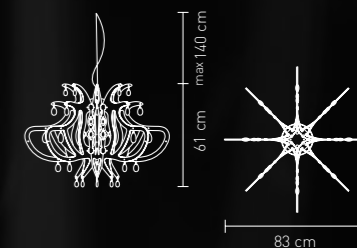
Si muove con fluidità e grazia, protettrice e guardiana di ciò che la circonda. Un design elegante e sofisticato, impreziosito dai 40 pendenti in cristallo trasparenti con riflessi iridescenti, anche nel nuovo color peltro che dona un aspetto misterioso e seducente a quegli interior che cercano un tocco di stile e magnificenza.



MEDUSA design by Nigel Coates

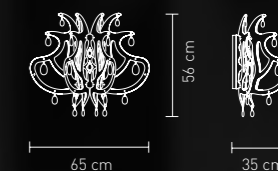
SUSPENSION

Bulbs E27:
1 X 8W LED Filament or
1 X 100W max - Halogen
Made of: Opalflex® / Cristalflex®
With: 56 Swarovski® Crystals



WALL LAMP

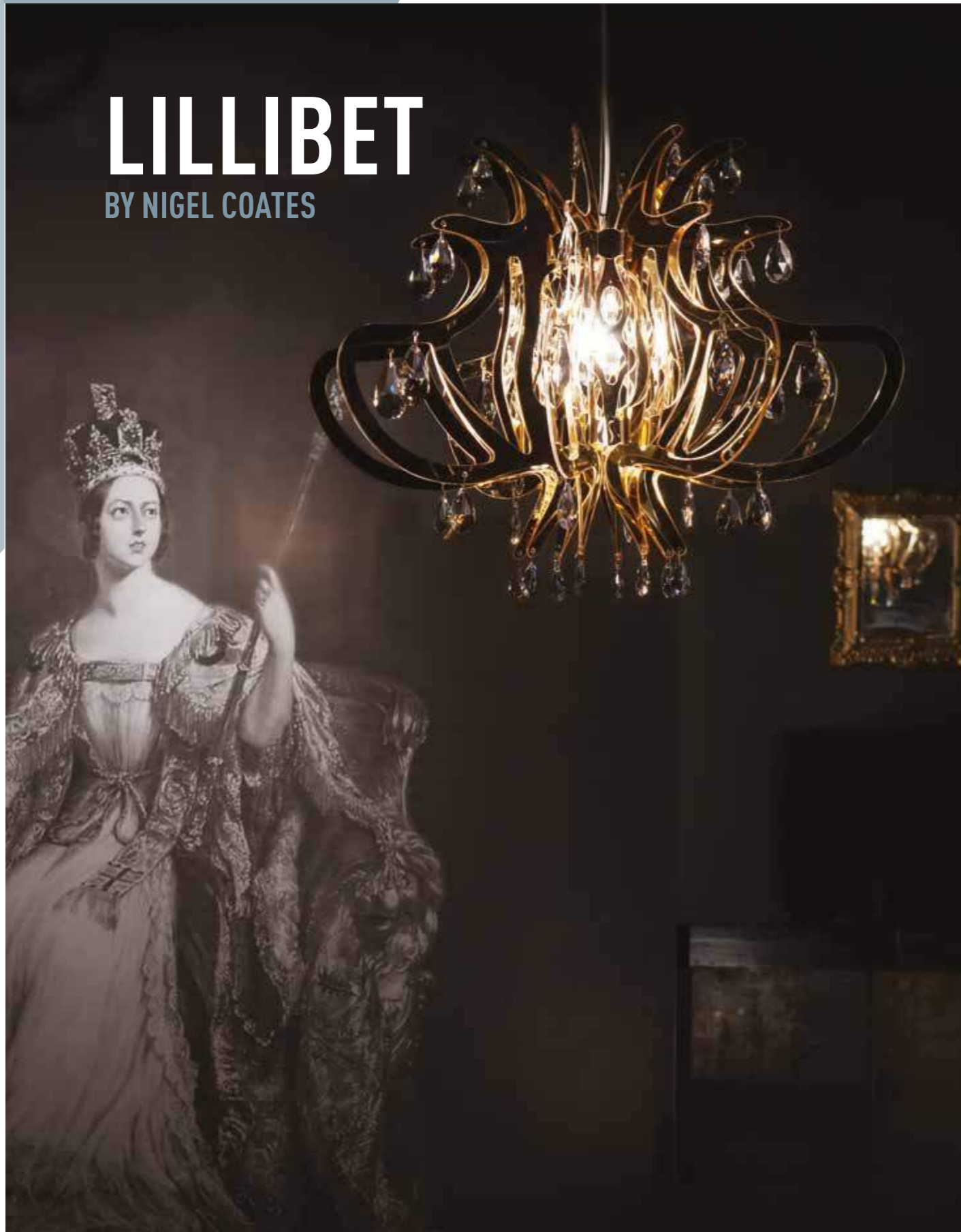
Bulbs E27:
1 X 8W LED Filament or
1 X 75W max - Halogen
Made of: Opalflex® / Cristalflex®
With: 26 Swarovski® Crystals
Stainless Steel support



List Ref: page 66

LILLIBET

BY NIGEL COATES



LILLIBET *Gold, Silver and Copper* by Nigel Coates

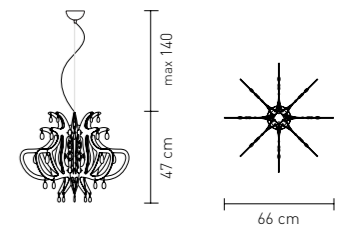
SUSPENSION

Bulbs E27:

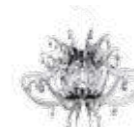
- 1 X 8W LED Filament or
- 1 X 100W max - Halogen

Made of: Goldflex®/Steelflex®/Copperflex®

With: 56 Schöler Crystals
Ceiling Rose Matching Colour



GOLD



SILVER



COPPER

List Ref: page 67

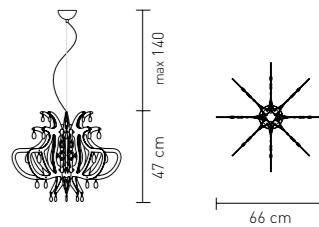


LILLIBET

 design by Nigel Coates

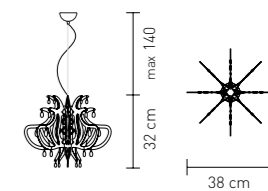
SUSPENSION

Bulbs E27:
1 X 8W LED Filament or
1 X 100W max - Halogen
Made of: Opalflex® or Cristalflex®
With: 56 Schöler Crystals



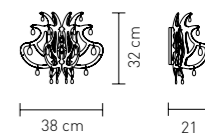
MINI SUSPENSION

Bulbs E14:
1 X 4W LED Filament or
1 X 25W max - Halogen
Made of: Opalflex® or Cristalflex®
With: 42 Schöler Crystals



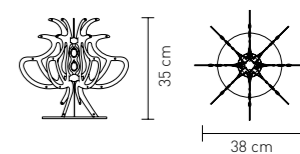
MINI WALL LAMP

Bulbs E14:
1 X 4W LED Filament or
1 X 25W max - Halogen
Made of: Opalflex® or Cristalflex®
With: 26 Schöler Crystals



COMODINA TABLE LAMP

Bulbs E14:
1 X 4W LED Filament or
1 X 28W max - Halogen
Made of: Opalflex® or Cristalflex®
With: 12 Schöler Crystals
Bulb included



List Ref: pages 67,68

FARETTO

BY NIGEL COATES

A contemporary form, a rigorous geometry, a rigid and penetrating line that softens around a central cone where overlapping circles play with the light without losing direction. Due to its suspension, double suspension and table versions, the collection transversely gives light to any interior.

Una forma contemporanea, una geometria rigorosa, una linea rigida e penetrante che si ammorbidisce intorno a un cono centrale dove cerchi sovrapposti giocano con la luce senza perdere la direzione. Grazie alle versioni suspension, double suspension e table, la collezione riesce trasversalmente a dar luce ad ogni ambiente.

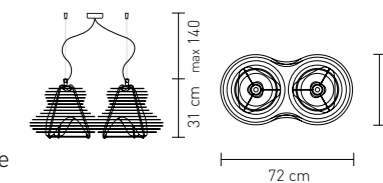




FARETTO design by Nigel Coates

DOUBLE SUSPENSION

Bulbs E27:
2 X 8W LED Filament or
2 X 75W max - Halogen
Made of: Plainflex® / Polycarbonate



SUSPENSION

Bulbs E27:
1 X 8W LED Filament or
1 X 75W max - Halogen
Made of: Plainflex® / Polycarbonate

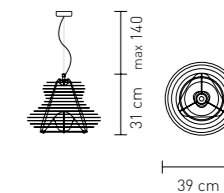
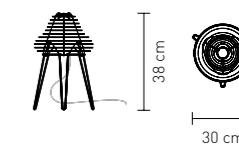


TABLE LAMP

Bulbs E27:
1 X 8W LED Filament or
1 X 40W max - Halogen
Made of: Plainflex® / Polycarbonate
With: Dimmer



List Ref: page 69

AURORA

BY NIGEL COATES

A cascade of crystals amplifies the light of this refined ceiling-lamp, which appears to dance in time with its reflections, gently dispersing its magical effect into every corner of the room. A practical and romantic choice, thanks to its ingenious magnetic base, for every interior that needs to shine.

Una cascata di cristalli amplifica la luce di questa raffinata plafoniera, che sembra quasi volteggiare al ritmo dei suoi riflessi, mentre diffonde grazia ed eleganza in tutta la stanza. Una scelta tanto romantica quanto funzionale, grazie al supporto magnetico, per tutti quegli spazi che amano brillare.





AURORA design by Nigel Coates

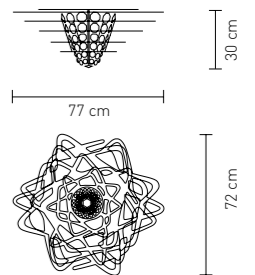
LARGE CEILING LAMP

Bulbs E27:

1 X 8W LED Filament or
1 X 100W max - Halogen

Made of: Plainflex® / Cristalflex®
97 Crystals

With: MagneticSystem®



BLACK



WHITE

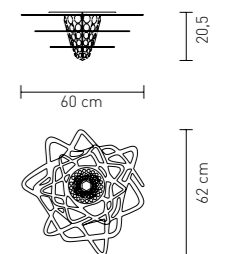
MINI CEILING LAMP

Bulbs E27:

1 X 8W LED Filament or
1 X 100W max - Halogen

Made of: Plainflex® / Cristalflex®
61 Crystals

With: MagneticSystem®



BLACK



WHITE



FUMÉ



TRANSPARENT

List Ref: page 70

WOODY

BY LUCA MAZZA

A minimalist design, with a marked and dynamic graphic line, where light, form and decoration framework the space into a striking and contemporary painting. Woody is a collection of lamps inspired by nature and the world of animals. In the floor version with adjustable arc, the light oak base evokes the knots and grain textures of the suspension lamps, both available in 4 colours.

Design minimalista, tratto grafico deciso e dinamico dove luce, forma e decoro incorniciano lo spazio in un quadro suggestivo e contemporaneo. Woody è una collezione di lampade ispirata alla naturalità e al mondo animale. Nella versione da terra con arco regolabile, la base in legno di rovere chiaro richiama la texture di nodi e venature della sospensione, entrambe disponibili in 4 colori.

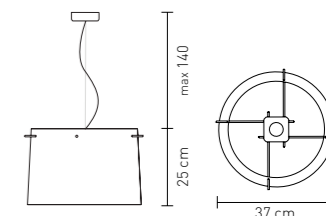




WOODY design by Luca Mazza

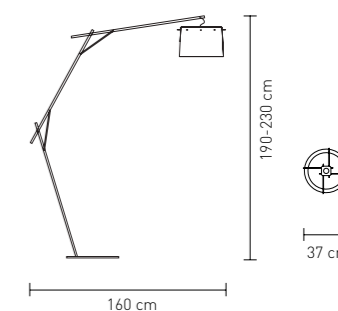
SUSPENSION

Bulbs E27:
1 X 8W LED Filament or
1 X 100W max - Halogen
Made of: Polycarbonate / Wood



FLOOR LAMP

Bulbs E27:
1 X 8W LED Filament or
1 X 100W max - Halogen
Made of: Polycarbonate / Wood
With: Wood base
Dimmer



List Ref: page 71

GINETTA

BY NIGEL COATES

The digital evolution of the classic eight-branched chandelier. Sumptuous in its contemporary interpretation, the lamp is structured around a central light source. From the most modern space to the aristocratic mansion, it fits in perfectly anywhere. Particularly dramatic when hung as a pair over a long table.

L'evoluzione digitale del classico candeliere a 8 bracci. Suntuosa nella sua contemporaneità, si sviluppa attorno a una fonte luminosa centrale e crea riflessi eleganti e raffinati. Si intona perfettamente alle location più attuali così come alle dimore più aristocratiche. Scenografica se installata in coppia su un lungo tavolo.





GINETTA PRISMA design by Nigel Coates

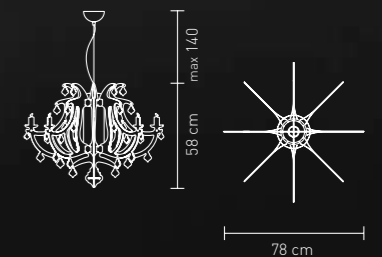
SUSPENSION

Bulbs E27:

- 1 X 8W LED Filament or
- 1 X 100W max - Halogen -max \varnothing 32

Made of: Lentiflex®

With: Iridescent bulb screen
MagneticSystem®



PRISMA

List Ref: page 72

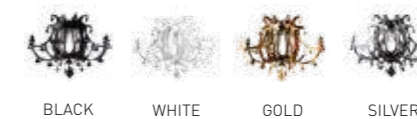
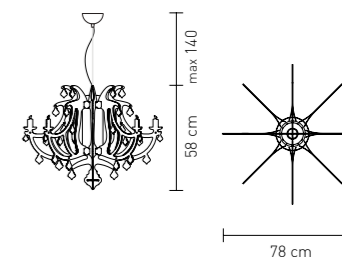


GINETTA design by Nigel Coates

SUSPENSION

Bulbs E27:
1 X 8W LED Filament or
1 X 100W max - Halogen

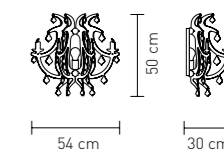
Made of: Black: Opalflex® / Cristalflex®
White: Opalflex® / Cristalflex®
Gold: Goldflex®
Silver: Steelflex®



WALL LAMP

Bulbs E27:
1 X 8W LED Filament or
1 X 75W max - Halogen

Made of: Black: Opalflex® / Cristalflex®
White: Opalflex® / Cristalflex®
Silver: Steelflex®

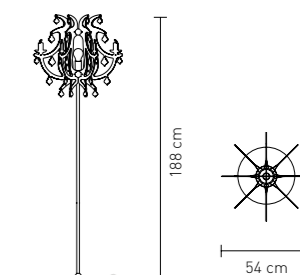


FLOOR LAMP

Bulbs E27:
1 X 8W LED Filament or
1 X 75W max - Halogen

Made of: Black: Opalflex® / Cristalflex®
White: Opalflex® / Cristalflex®
Silver: Steelflex®

With: Stainless Steel base and stem



List Ref: page 73

MILLE BOLLE

BY ADRIANO RACHELE

The fleeting thrill of soap bubbles, the memories of a never too far away past, a romantic play of light and precious timeless reflections. The iridescent charm of the diffuser, artfully folded like an origami, is lit up under an almost invisible light source generating a large collection (wall, floor, table and suspension) capable of tickling youthful fancy and stimulating the imagination.

L'emozione fugace delle bolle di sapone, i ricordi di un passato mai troppo lontano, un romantico gioco di luci e preziosi riflessi senza tempo. Il fascino iridescente del diffusore piegato ad arte come in un origami si accende sotto una fonte luminosa quasi invisibile generando un'ampia collezione (wall, floor, table e suspension) capace di solleticare l'infanzia e stimolare la fantasia.





MILLE BOLLE design by Adriano Rachele

SUSPENSION

Bulbs G9:
 1 X 2W LED or
 1 X 75W max - Halogen
 Made of: Iridescent Polycarbonate
 With: Stainless Steel
 Bulb Included

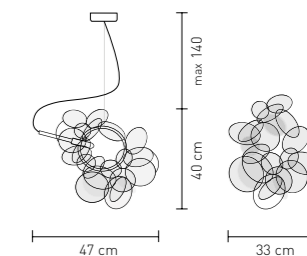
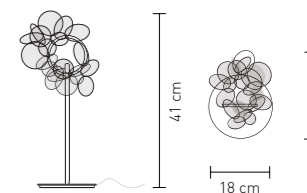


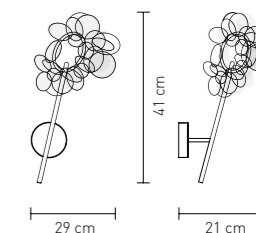
TABLE LAMP

Bulbs G4:
 1 X 3W LED or
 1 X 20W max - 12V Halogen
 Made of: Iridescent Polycarbonate
 With: Stainless Steel Base
 Bulb Included



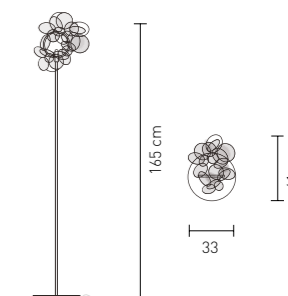
WALL LAMP

Bulbs G4:
 1 X 3W LED or
 1 X 20W max - 12V Halogen
 Made of: Iridescent Polycarbonate
 With: Stainless Steel Support
 Bulb Included



FLOOR LAMP

Bulbs G9:
 1 X 2W LED or
 1 X 75W max - Halogen
 Made of: Iridescent Polycarbonate
 With: Stainless Steel base
 Bulb Included
 Dimmer



IRIDESCENT POLYCARBONATE

List Ref: page 74

HELIOS

BY SLAMP TEAM

Standing 182 cm high, this lamp is inspired by a remote waterfall. 120 LED lights run vertically inside a transparent cylinder that stands on a base turned from prestigious Carrara marble. The effect is of rippling iridescent colour, which can be adjusted with the dimmer switch.

Con i suoi 182 cm si ispira a una cascata d'acqua e ne conserva fluidità e suggestione. Da una prestigiosa base in marmo di Carrara si eleva un cilindro trasparente, al cui interno gioca e si scompone la luce di ben 120 LED. L'effetto cromatico è cangiante e, con il dimmer digitale, è possibile ricreare ogni giorno l'intensità luminosa preferita.







HELIOS design by Slamp Team

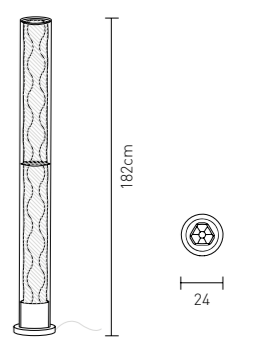
FLOOR LAMP

LED: 50W - 24V - 3800 Lumen
2700 Kelvin (Warm white)



Made of: Lentiflex®/Methacrylate

With: Carrara Marble Base
Dimmer



PRISMA

List Ref: pages 75

DIAMOND

BY PAOLUCCI, STATERA

Sculptural, dynamic, irregular and contemporary. Just let the light inside the Opalflex® surfaces activate its distinctive triangulated structure. Available in three different sizes so as to adapt to any setting.

Scultorea, dinamica, irregolare e contemporanea. Basta che la luce incontri le superfici di Opalflex® per accentuarne le forme sfaccettate, delinearne l'identità e accenderne la struttura decisa. Nelle tre diverse dimensioni rimane perfettamente adeguata a ogni arredo.



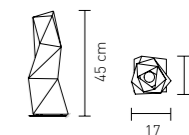
DIAMOND design by Paolucci, Statera

SMALL TABLE LAMP

Bulbs E14:
1 X 4W LED Filament or
1 X 40W max - Halogen

Made of: Opalflex®

With: Aluminium base

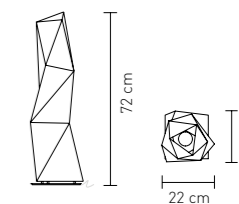


MEDIUM TABLE LAMP

Bulbs E27:
1 X 8W LED Filament or
1 X 60W max - Halogen

Made of: Opalflex®

With: Aluminium base

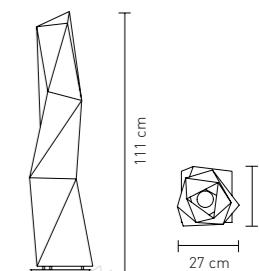


LARGE TABLE LAMP

Bulbs E27:
1 X 8W LED Filament or
1 X 75W max - Halogen

Made of: Opalflex®

With: Aluminium base



WHITE

List Ref: page 76

SUPERMORGANA

BY STEFANO PAPI

Splendid and legendary, SuperMorgana's enchanting forms remind you of phials and crucibles. Everything about her is magical, even the ability to be suspended by an almost invisible thread. Seen from below, another spell is revealed: a pattern like the paved surface of the Piazza del Campidoglio in Rome.

Splendida e leggendaria, ammalia con le sue forme che richiamano alambicchi ed ampolle. Tutto in lei sembra magico, persino la capacità di restare sospesa grazie a un filo quasi invisibile. Vista dal basso rivela un altro incantesimo: la sua prospettiva somiglia a quella del rosone di Piazza del Campidoglio a Roma.





SUPERMORGANA design by Stefano Papi

SUSPENSION

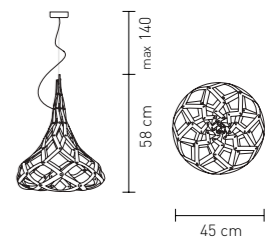
Bulbs G9:

1 X 2W LED or

1 X 75W max - Halogen

Made of: Metallized Polycarbonate

With: Bulb included



MIRROR/BLACK



MIRROR/WHITE



GOLD/BLACK



GOLD/WHITE

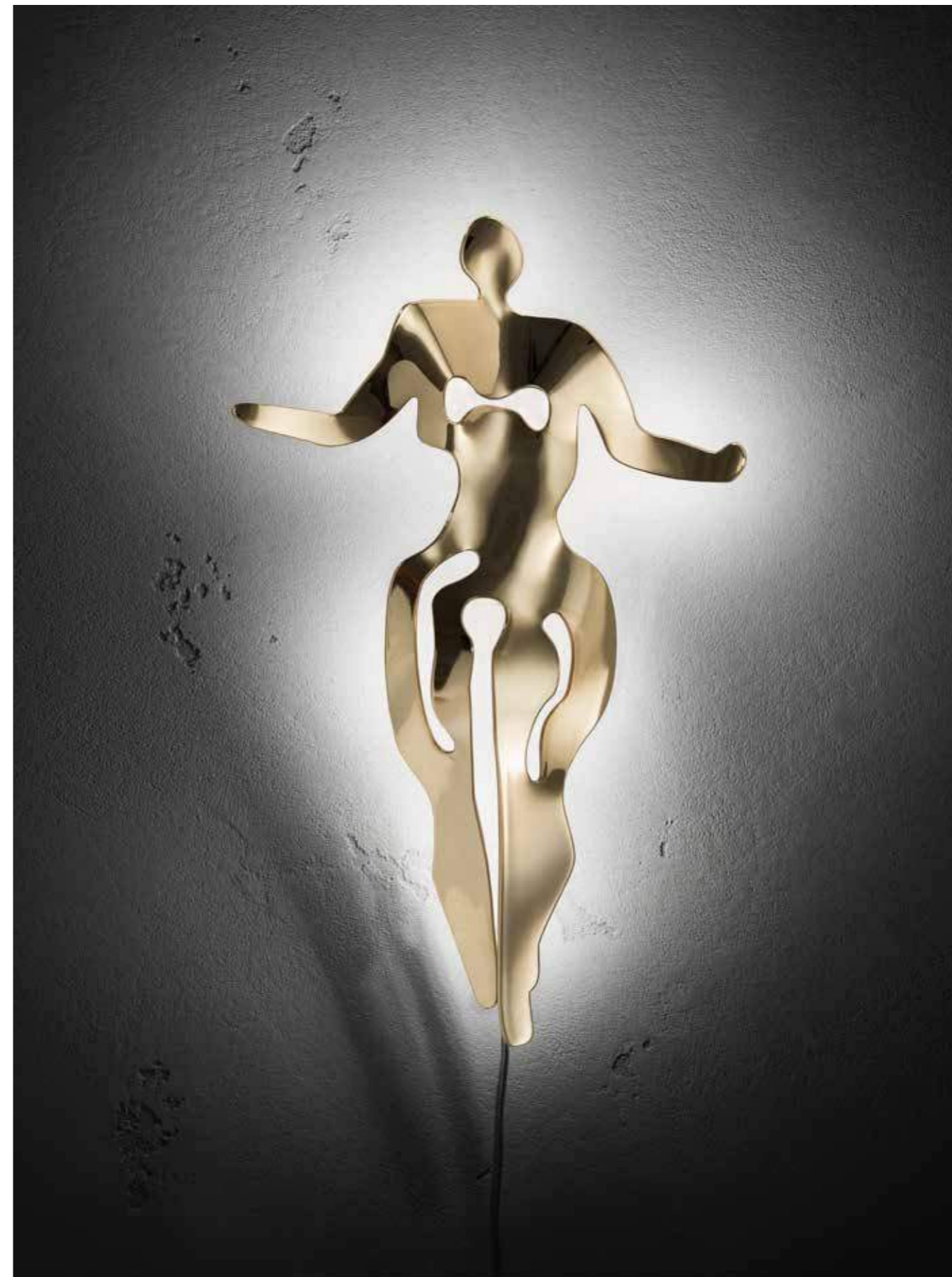
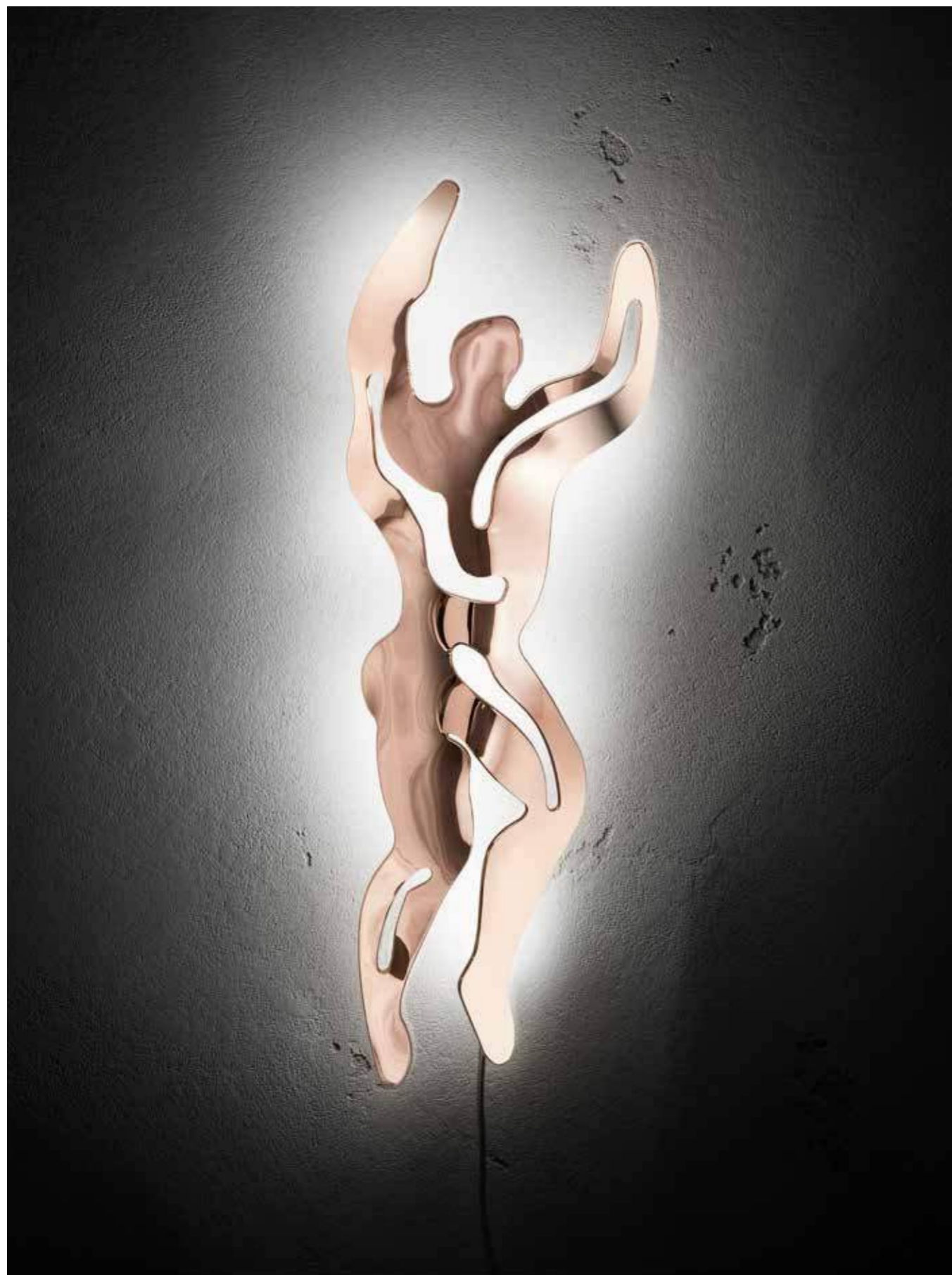
List Ref: page 77

ILLUMINATI

BY NIGEL COATES

In perfect contemporary style, Coates reinterprets ancestral symbols to create a collection of wall-mounted lamps for the most intimate areas of your home. Cuore is red, symbolising faithfulness, devotion and passion; Uomo, suggesting ambition, strength and value, is coated in copper; Donna the source of precious life and security, has a finish of pure gold.

In chiave perfettamente contemporanea, Coates rilegge simboli ancestrali creando una collezione di applique in policarbonato verniciato perfette per le zone più intime della casa. Il Cuore è rosso, a simboleggiare lealtà, devozione e passione; l'Uomo è rame, a indicare aspirazione, forza e valore; la Donna è oro: fonte di vita preziosa e sicura.





ILLUMINATI

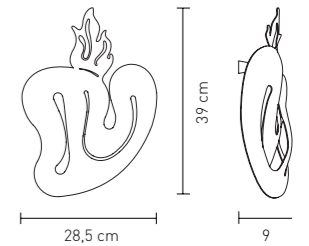
 design by Nigel Coates

CUORE - WALL LAMP

LED: 8W - 12V - 600 Lumen
2700 Kelvin (warm white)

Made of: Plainflex®

With: Power Supply Included



RED

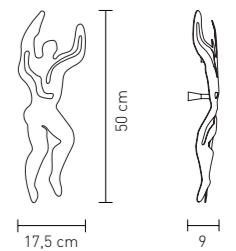
List Ref: page 78

UOMO - WALL LAMP

LED: 6,5W - 12V - 500 Lumen
2700 Kelvin (warm white)

Made of: Plainflex® Bronze plated

With: Power Supply Included



BRONZE

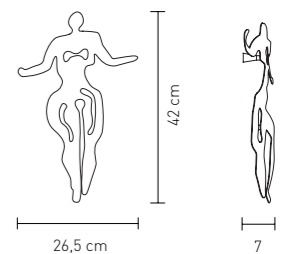
List Ref: page 78

DONNA - WALL LAMP

LED: 6W - 12V - 450 Lumen
2700 Kelvin (warm white)

Made of: Plainflex® Gold plated

With: Power Supply Included



GOLD

List Ref: page 78

PUNCTUM

BY NIGEL COATES

In a new language of voluptuous minimalism, this LED lamp is designed for corners. Its highly polished steel mirror destabilises the architecture of your home, and breaks the line of walls to create unexpected changes of perspective. Whether wall or floor-mounted, Punctum opens up a contemporary, even experimental, space.

In un nuovo linguaggio di minimalismo sensuale, questa lampada a LED è progettata per gli angoli. La sua superficie specchiata destruttura l'architettura domestica e rompe la linearità delle pareti creando dei cambi di prospettiva inaspettati. Che sia montato a terra o a parete, Punctum esplora uno spazio contemporaneo e audace.



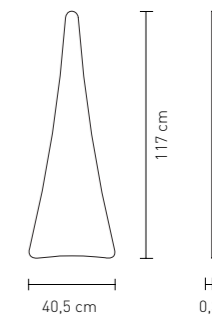
PUNCTUM design by Nigel Coates

FLOOR LAMP

LED: 19,2W - 12V - 1500 Lumen
2700 Kelvin (warm white)

Made of: Supermirror Steel®

With: Power Supply Included

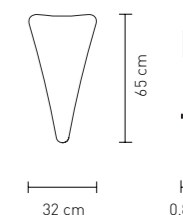


WALL LAMP

LED: 12,6W - 12V - 1000 Lumen
2700 Kelvin (warm white)

Made of: Supermirror Steel®

With: Power Supply Included
Magnetic System



MIRROR

List Ref: page 79

SUPERSTAR

BY PAGANI E PERVERSI

With its energetic asymmetrical outline, and a rippling play of light, this lamp enhances a room with refractive effects that reach along its points. A magnetic lamp fixture makes it easy to clean and assemble. Used in a pair at different heights, it brings dynamism into any space.

Fa risplendere l'ambiente, grazie a un design deciso e a una luminosità cangiante, arricchita da seducenti riflessi che arrivano fino alle punte. L'attacco magnetico ne facilita pulizia e montaggio. In coppia a diverse altezze danno dinamismo allo spazio.



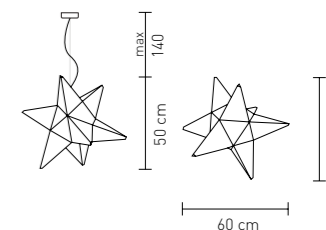
SUPERSTAR design by Pagani e Perversi

MEDIUM SUSPENSION

Bulbs E27:
1 X 8W LED Filament or
1 X 75W max - Halogen

Made of: Lentiflex® /
Iridescent Polycarbonate

With: MagneticSystem®

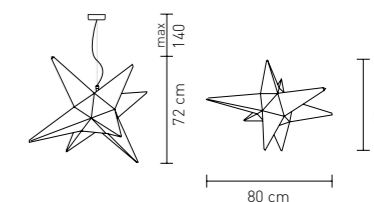


LARGE SUSPENSION

Bulbs E27:
1 X 8W LED Filament or
1 X 75W max - Halogen

Made of: Lentiflex® /
Iridescent Polycarbonate

With: MagneticSystem®



PRISMA

List Ref: page 80

CHAPEAU

BY NIGEL COATES

A contemporary design full of captivating and dynamic character. Its mirrored inner surface contrasts with the black outer coating to create a particularly elegant pooling of light directed downwards. An original and functional household accessory, perfect partner for a favourite reading chair.

Design contemporaneo, ricco di carattere dinamico e attraente. L'interno è specchiato, avvolto in uno strato nero, per creare una rifrazione particolarmente elegante della luce, sia verso il basso sia verso il soffitto. Un complemento d'arredo originale e funzionale, partner perfetto per una sedia da lettura.





CHAPEAU

design by Nigel Coates

SUSPENSION

Bulbs E27:
1 X 8W LED Filament or
1 X 100W max - Halogen
Made of: Polycarbonate /
Stainless Steel

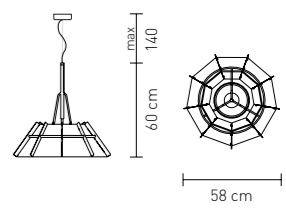
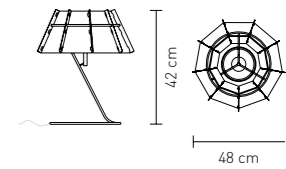


TABLE LAMP

Bulbs E14:
1 X 4W LED Filament or
1 X 40W max - Halogen
Made of: Polycarbonate /
Stainless Steel

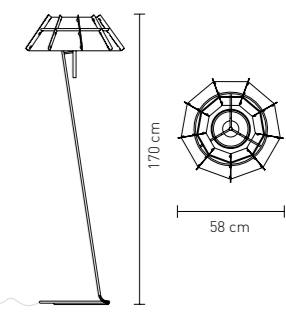
With: Dimmer



FLOOR LAMP

Bulbs E27:
1 X 8W LED Filament or
1 X 100W max - Halogen
Made of: Polycarbonate /
Stainless Steel

With: Dimmer



MIRROR/BLACK

List Ref: page 81

GOCCIA

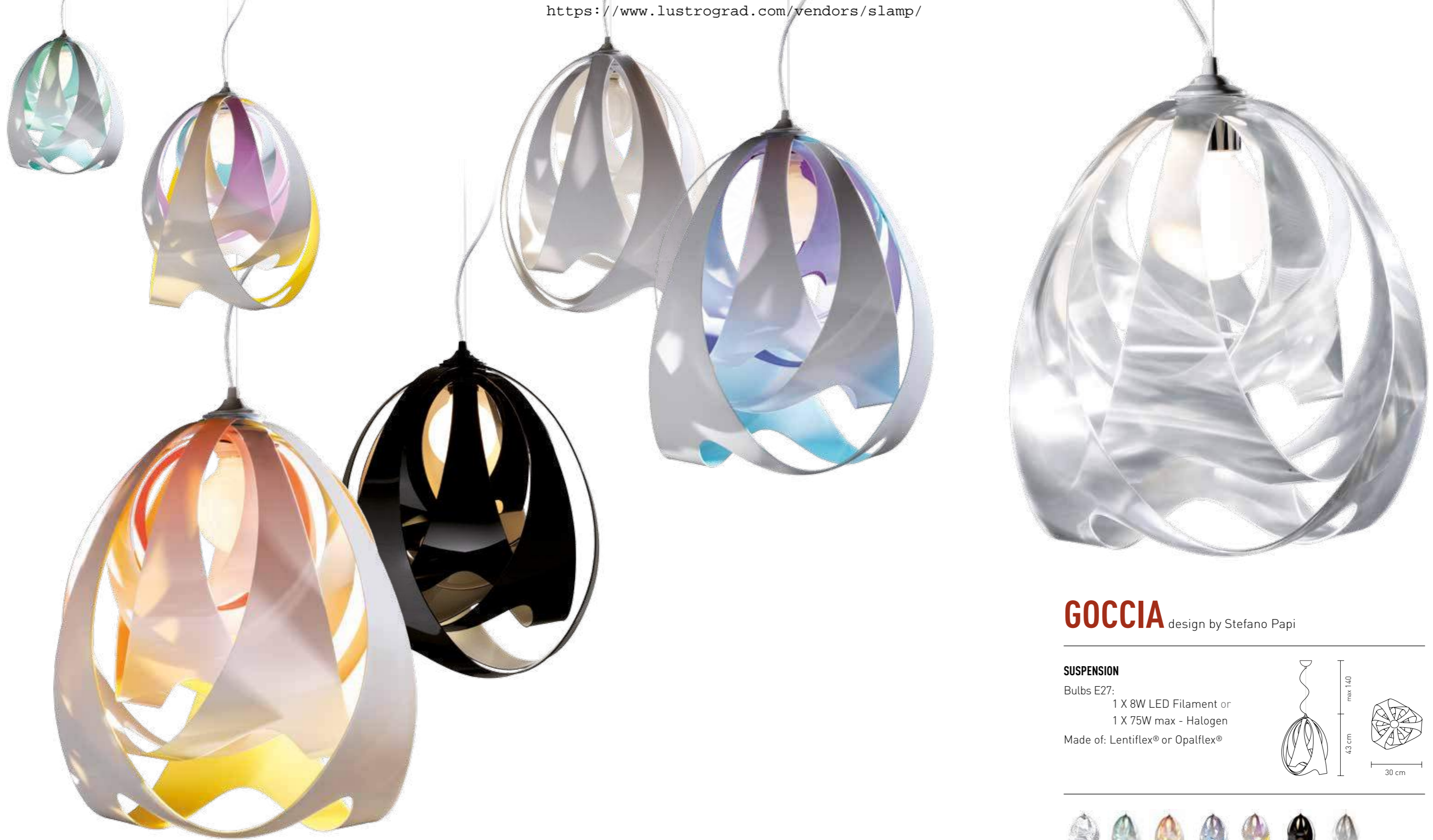
BY STEFANO PAPI

Following the fluid and lightweight form of water, Goccia plays with light, donating extraordinary effects and reflections of illumination in both the Prisma version in Lentiflex® and in the coloured versions. Liquid yet compact, soft and shiny, it brings freshness to the home environment and, especially when used in multiples, it decorates ample and sinuous spaces.

Seguendo la forma fluida e leggera dell'acqua, Goccia gioca con la luce, regalando sia nelle versioni Prisma in Lentiflex® che nelle versioni colorate effetti e riflessi di luce straordinari.

Liquida ma compatta, morbida e brillante, porta freschezza agli ambienti domestici e decora spazi ampi e sinuosi specialmente se usata in multipli.

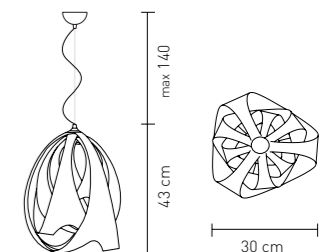




GOCCIA design by Stefano Papi

SUSPENSION

Bulbs E27:
1 X 8W LED Filament or
1 X 75W max - Halogen
Made of: Lentiflex® or Opalflex®



List Ref: page 82

BATTISTA

BY NIGEL COATES

A luminous sculpture that prepares your home to welcome your guests. Perfectly combining technology and nature, the upper structure in white-printed Crystalflex® stands on a poplar base made from recycled timber beams.

Una scultura luminosa che coniuga perfettamente natura e tecnologia. Ha una base di pioppo, ricavata da antiche travi riciclate, su cui poggia una struttura in Cristalflex® delicatamente pennellata di bianco. Battista rende l'ambiente più confortevole e si prepara ad accogliere gli ospiti.



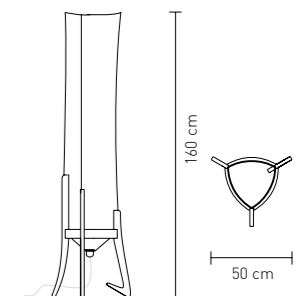
BATTISTA design by Nigel Coates

FLOOR LAMP

Bulbs E27:
1 X 16W Spot LED or
1 X 75W max - Spot Halogen

Made of: Cristalflex®
Reclaimed Wood

With: Dimmer
Signature by the Artist



FUMÉ

List Ref: page 83

BIOS

BY NIGEL COATES

A soft and naturalistic design for a linear lamp with tone-on-tone decoration. Two layers of Opalflex® with irregular holes suggest the complex voids in many natural materials. The lamp allows light to filter through its layers, creating suggestive shadows and reflections.

Un design morbido ed avvolgente per una lampada lineare, decorata tono su tono. Nasce dalla sovrapposizione di due strati di Opalflex® dai quali, attraverso fori irregolari, filtra una luce che crea suggestivi riflessi e dona nuova vita a ogni ambiente domestico.



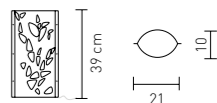
BIOS decor by Nigel Coates

SMALL TABLE LAMP

Bulbs E14:
1 X 4W LED Filament or
1 X 40W max - Halogen

Made of: Opalflex®

With: Aluminium profiles

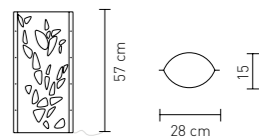


MEDIUM TABLE LAMP

Bulbs E27:
1 X 8W LED Filament or
1 X 75W max - Halogen

Made of: Opalflex®

With: Aluminium profiles

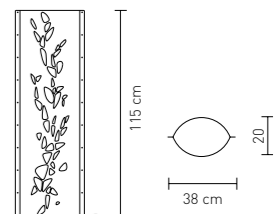


LARGE TABLE LAMP

Bulbs E27:
2 X 8W LED Filament or
2 X 75W max - Halogen

Made of: Opalflex®

With: Aluminium profiles

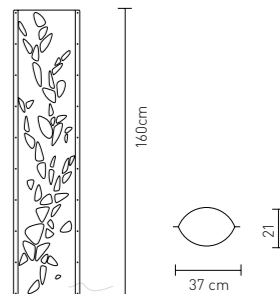


EXTRALARGE TABLE LAMP

Bulbs E27:
3 X 8W LED Filament or
3 X 75W max - Halogen

Made of: Opalflex®

With: Aluminium profiles,
Dimmer



WHITE

List Ref: page 84

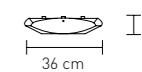


BIOS decor by Nigel Coates

SMALL CEILING-WALL LAMP

Bulbs E27:
2 X 8W LED Filament or
2 X 20W FBT - max length 105mm

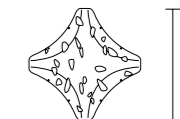
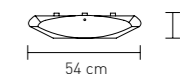
Made of: Opalflex®
With: MagneticSystem®



MEDIUM CEILING-WALL LAMP

Bulbs E27:
3 X 8W LED Filament or
3 X 20W FBT - max length 115mm

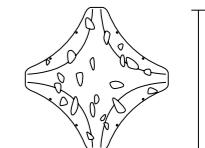
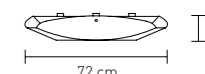
Made of: Opalflex®
With: MagneticSystem®



LARGE CEILING-WALL LAMP

Bulbs E27:
4 X 8W LED Filament or
4 X 24W FBT

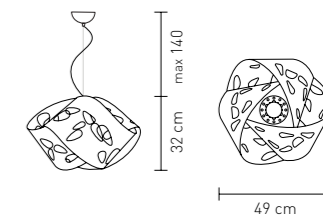
Made of: Opalflex®
With: MagneticSystem®



SUSPENSION "NODO"

Bulbs E27:
1 X 8W LED Filament or
1 X 24W FBT

Made of: Opalflex®



WHITE

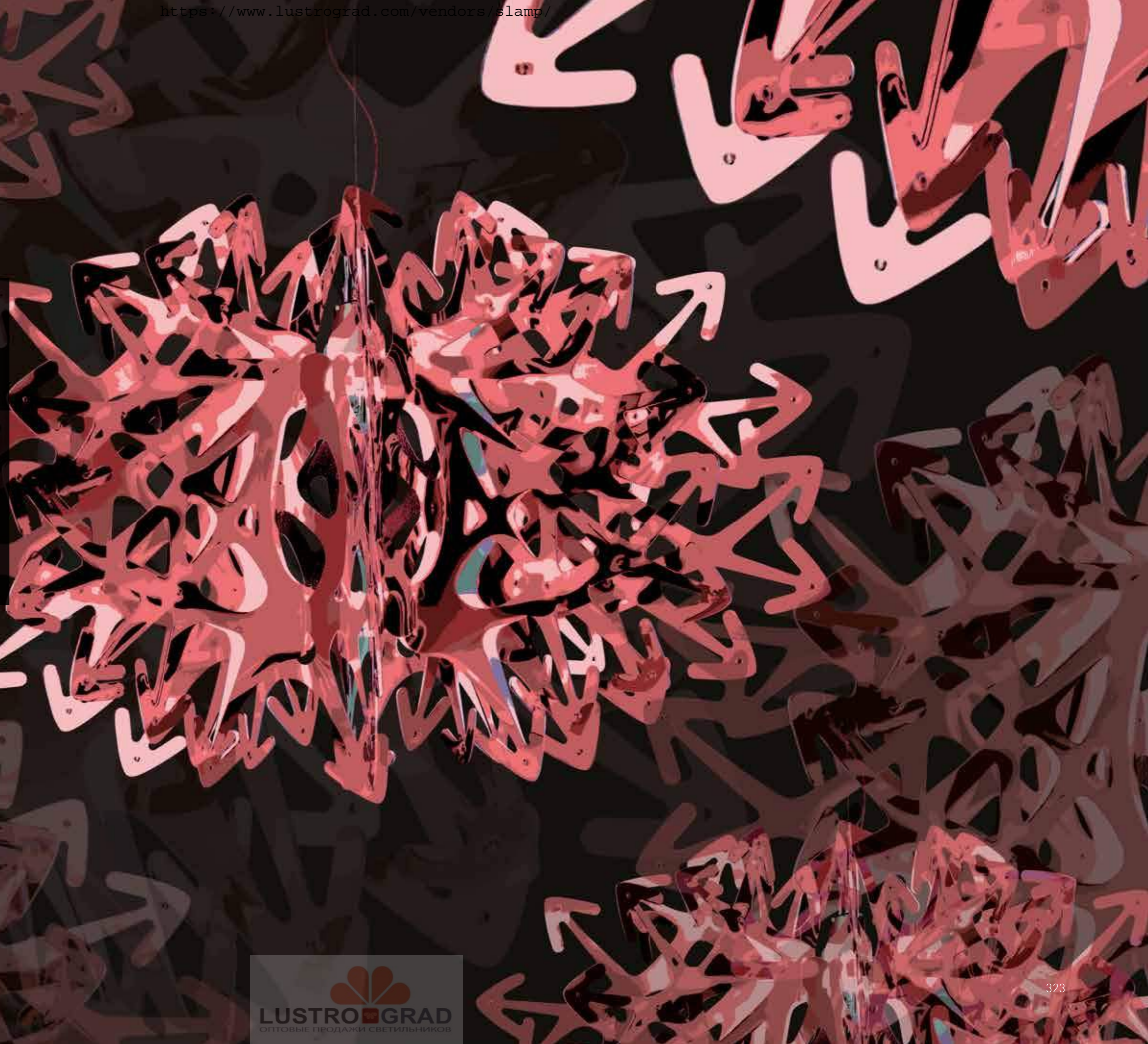
List Ref: page 85

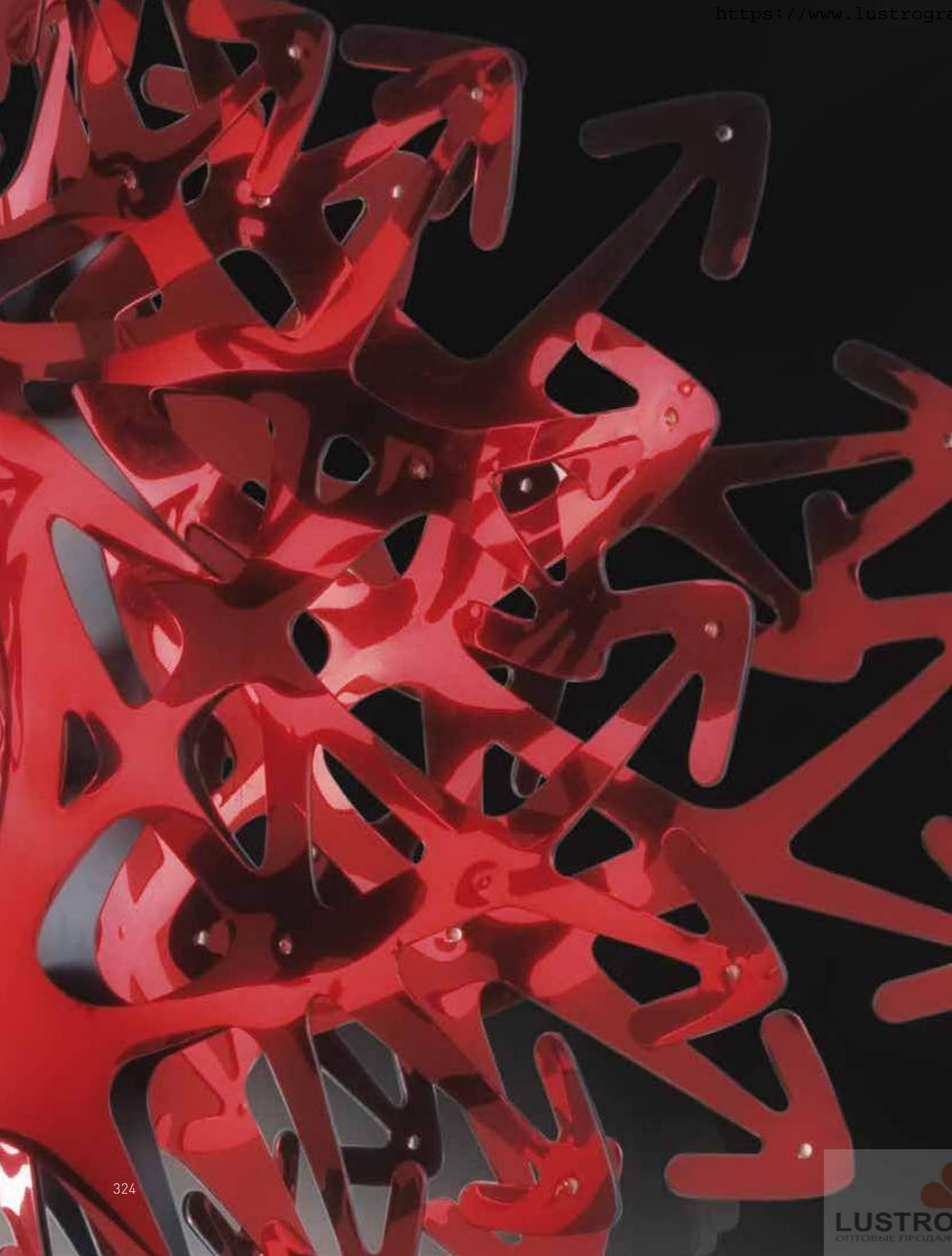
DEVIL

BY NIGEL COATES

A lamp with a decisive and subtly mischievous design. With its countless Steelflex® darts, it demands attention, and captures the gaze of anyone who sees it. Its reflective deep red accentuates its mysterious and seductive character. The perfect choice for large spaces that need a touch of personality and charisma.

Possiede un tratto grafico deciso e sexy. Colpisce l'attenzione con tantissime frecce di Steelflex® pronte a catturare chi la guarda. Il colore rosso scuro ne accentua il carattere misterioso e seducente. Una tentazione per i grandi spazi che hanno bisogno di personalità e carisma.

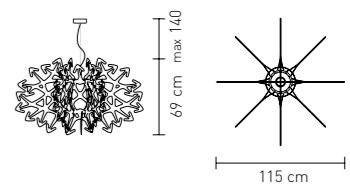




DEVIL design by Nigel Coates

SUSPENSION

Bulbs R7S:
1 X 10W R7S LED or
1 X 240W max - R7S Halogen
max length 118 mm



Made of: Steelflex®



RED

List Ref: page 86

DAFNE

BY NIGEL COATES

A lamp that generates a feeling of peace and wellbeing. Its quality lies in the subtle, tone-on-tone printed decoration inspired by olive branches. Made in two shapes – as a rectangular wall or ceiling lamp, or a floor standing classic tube.

Una lampada che, con la sua luce, genera una sensazione di pace ed equilibrio interiore. Il segreto del suo fascino sta nel delicato decoro tono su tono, ispirato al mondo naturale. Per rendere più accoglienti piccoli disimpegni nella versione plafoniera, o angoli nascosti nella versione da terra.



DAFNE decor by Nigel Coates

SMALL TABLE LAMP

Bulbs E14:
1 X 4W LED Filament or
1 X 40W max - Halogen

Made of: Opalflex®

With: Aluminium profiles



MEDIUM TABLE LAMP

Bulbs E27:
1 X 8W LED Filament or
1 X 75W max - Halogen

Made of: Opalflex®

With: Aluminium profiles

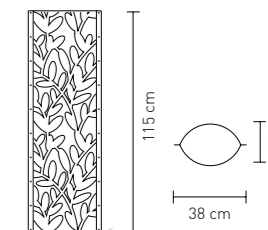


LARGE TABLE LAMP

Bulbs E27:
2 X 8W LED Filament or
2 X 75W max - Halogen

Made of: Opalflex®

With: Aluminium profiles

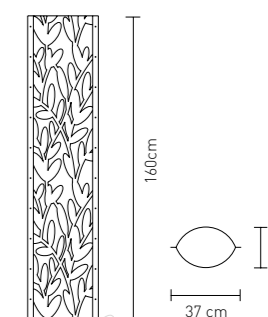


EXTRALARGE TABLE LAMP

Bulbs E27:
3 X 8W LED Filament or
3 X 75W max - Halogen

Made of: Opalflex®

With: Aluminium profiles,
Dimmer



HYPERWHITE EFFECT

List Ref: pages 88

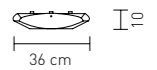


DAFNE decor by Nigel Coates

SMALL CEILING-WALL LAMP

Bulbs E27:
2 X 8W LED Filament or
2 X 20W FBT - max length 115mm

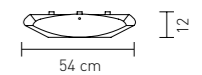
Made of: Opalflex®
With: MagneticSystem®



MEDIUM CEILING-WALL LAMP

Bulbs E27:
3 X 8W LED Filament or
3 X 20W FBT - max length 105mm

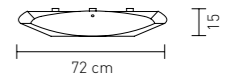
Made of: Opalflex®
With: MagneticSystem®



LARGE CEILING-WALL LAMP

Bulbs E27:
4 X 8W LED Filament or
4 X 24W FBT

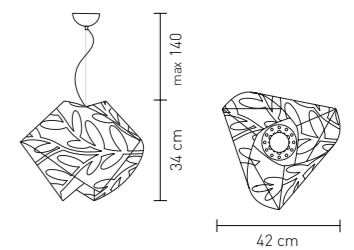
Made of: Opalflex®
With: MagneticSystem®



SUSPENSION "GEMMY DAFNE"

Bulbs E27:
1 X 8W LED Filament or
1 X 75W max - Halogen

Made of: Opalflex®



HYPERWHITE EFFECT

List Ref: page 89

CRAZY DIAMOND

BY LUCA MAZZA

As if an exploding block of ice, this clever light creates an atmosphere of vibrant freshness inside the room. Its many angled surfaces of Crystalflex® generate sparkle around the transparent crystal core.

Intorno al cestello di cristalli trasparenti brillano tutte le irregolarità delle superfici in Crystalflex®. Una lampada che sembra esplodere come un blocco di ghiaccio all'interno della stanza, per dare con la sua luce un'atmosfera di rinnovata freschezza.



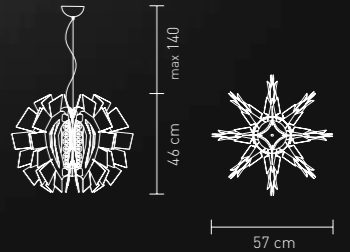
CRAZY DIAMOND design by Luca Mazza

SUSPENSION

Bulbs E27:
1 X 8W LED Filament or
1 X 75W max - Halogen

Made of: Cristalflex® / Polycarbonate

With: 48 Crystals



FUMÉ



TRANSPARENT

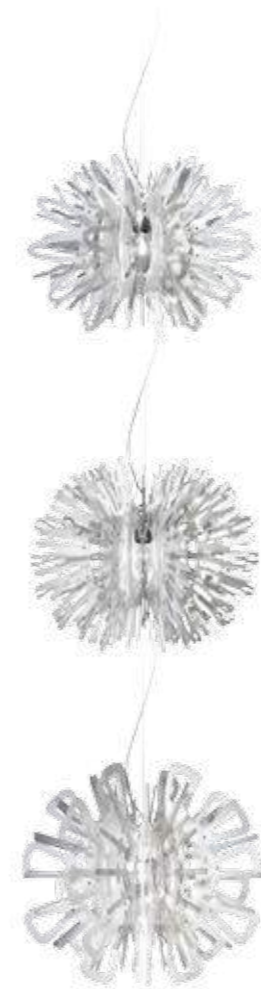
List Ref: page 87

CREATURES

BY NIGEL COATES

This trio of marine animals is almost alive with light. Charged with originality and atmosphere, the three together make a real statement. Created from tough, bright white Opalflex® with many smaller inserts in Fumé.

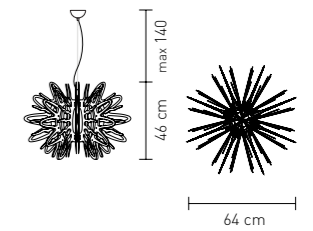
Un trio di creature marine che sembra diventare vivo con la luce. Arricchite di originalità e atmosfera, le tre lampade insieme creano una vera e propria composizione. Realizzate da un resistente quanto luminoso Opalflex® bianco con piccoli inserti in Fumé.



CREATURES design by Nigel Coates

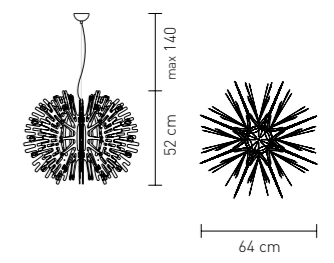
SMALL SUSPENSION

Bulbs E27:
1 X 8W LED Filament or
1 X 100W max - Halogen
Made of: Opalflex®



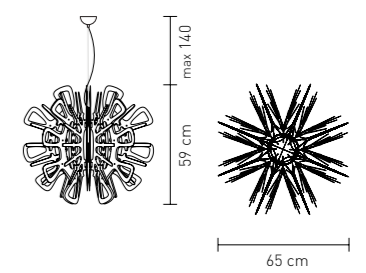
MEDIUM SUSPENSION

Bulbs E27:
1 X 8W LED Filament or
1 X 100W max - Halogen
Made of: Opalflex®



LARGE SUSPENSION

Bulbs E27:
1 X 8W LED Filament or
1 X 100W max - Halogen
Made of: Opalflex®



WHITE/ FUMÉ

List Ref: page 90

PACIS

BY NIGEL COATES

Symbolising peace, a cascade of crystal glides through a crown of laurel leaves, an effect enhanced by the rich contrast of elements. The design is graphic yet delicate, skilfully amplifying the light to superb effect. The magnetic attachment to the base makes it easy to maintain.

Una cascata di cristalli è avvolta da un'avveniristica corona d'alloro concentrica simbolo di pace. Un effetto che aumenta grazie al contrasto degli elementi. Il design grafico e delicato amplifica sapientemente l'effetto superbo della luce. Il supporto magnetico la rende perfettamente funzionale.



PACIS

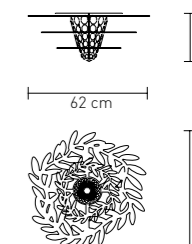
design by Nigel Coates

MINI CEILING LAMP

Bulbs E27:
1 X 8W LED Filament or
1 X 100W max - Halogen

Made of: Plainflex® - Cristalflex®

With: MagneticSystem®
61 Crystals

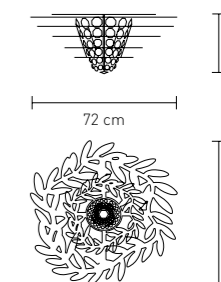


LARGE CEILING LAMP

Bulbs E27:
1 X 8W LED Filament or
1 X 100W max - Halogen

Made of: Plainflex® - Cristalflex®

With: MagneticSystem®
97 Crystals



WHITE

List Ref: pages 91

LUÌ

BY ADRIANO RACHELE

Inspired by the world's smallest bird from which it takes its name, it is protective and welcoming, like a nest to which one always wants to return. Delicate, dreamy and imaginative, it charms thanks to the play of reflections and shadows created by the many branches that surround the light diffuser. It adds a touch of magic to any minimal, coloured or eco-sustainable interior.

Ispirata all'uccellino più piccolo al mondo da cui prende il nome, è protettiva ed accogliente, come il nido a cui si vuol sempre tornare.

Delicata, sognante e fantasiosa incanta grazie ai giochi di riflessi ed ombre creati dai tanti rami che avvolgono il diffusore luminoso.

Aggiunge un tocco di magia ad ogni interior minimal, colorato o ecosostenibile.



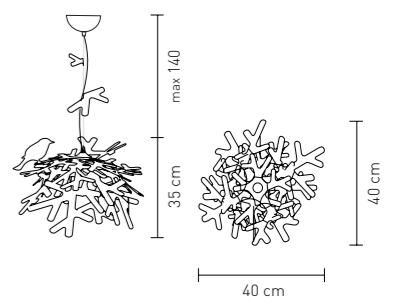
LUi design by Adriano Rachele

SUSPENSION

Bulbs E27:
1 X 8W LED Filament or
1 X 24W FBG

Made of: Cristalflex® / Opalflex®

With: Bulb included



List Ref: page 94

VENTI

BY ALESSANDRO MENDINI

Concentric circles, increasingly larger, soft and regular lines, like those generated by a stone thrown into a pond. The neutral décor, tone on tone of the floor, table and wall versions surround the light source, guiding the vibrations of light and transmitting a calm and relaxed atmosphere, as gentle and regular as the tide, capable of spreading on any interiors

Cerchi concentrici, sempre più grandi, linee morbide e regolari, come quelle generate da un sasso gettato nell'acqua. Il neutro decoro tono su tono delle versioni floor, table e wall avvolge la fonte luminosa guidando le vibrazioni della luce e trasmette un'atmosfera calma e rilassata, delicata e regolare come la marea, capace di distendersi su ogni interior.

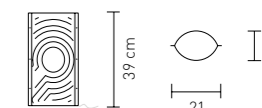


VENTI

 design by Alessandro Mendini

SMALL TABLE LAMP

Bulbs E14:
1 X 4W LED Filament or
1 X 40W max - Halogen

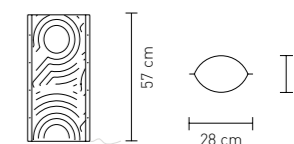


Made of: Opalflex®

With: Aluminium profiles

MEDIUM TABLE LAMP

Bulbs E27:
1 X 8W LED Filament or
1 X 75W max - Halogen

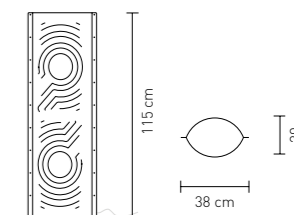


Made of: Opalflex®

With: Aluminium profiles

LARGE TABLE LAMP

Bulbs E27:
2 X 8W LED Filament or
2 X 75W max - Halogen

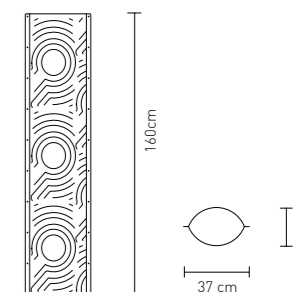


Made of: Opalflex®

With: Aluminium profiles

EXTRALARGE TABLE LAMP

Bulbs E27:
3 X 8W LED Filament or
3 X 75W max - Halogen



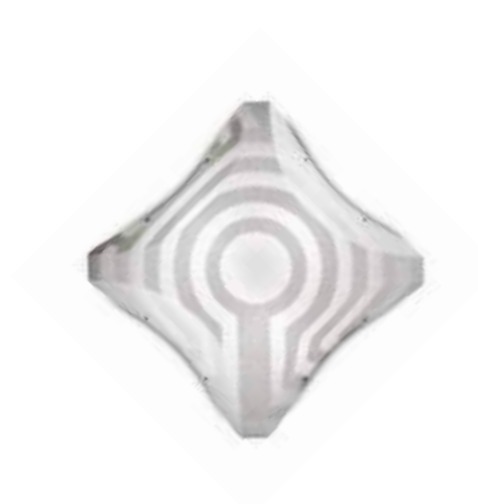
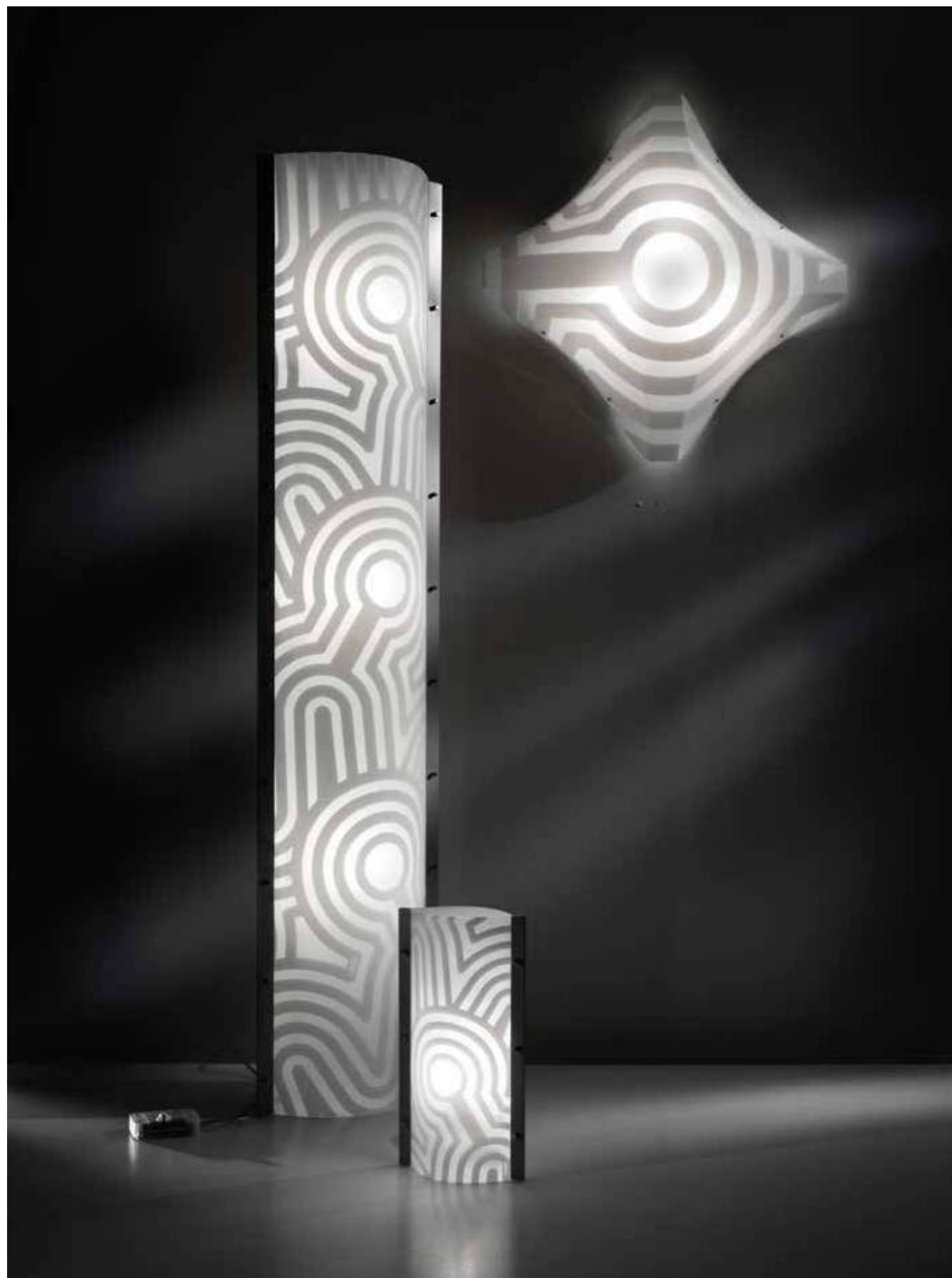
Made of: Opalflex®

With: Aluminium profiles,
Dimmer



HYPERWHITE EFFECT

List Ref: page 96

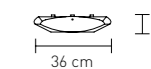


VENTI design by Alessandro Mendini

SMALL CEILING-WALL LAMP

Bulbs E27:
2 X 8W LED Filament or
2 X 20W FBT - max length 115mm

Made of: Opalflex®
With: MagneticSystem®



MEDIUM CEILING-WALL LAMP

Bulbs E27:
3 X 8W LED Filament or
3 X 20W FBT - max length 105mm

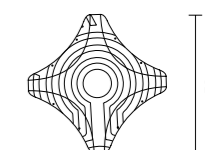
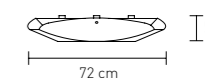
Made of: Opalflex®
With: MagneticSystem®



LARGE CEILING-WALL LAMP

Bulbs E27:
4 X 8W LED Filament or
4 X 24W FBT

Made of: Opalflex®
With: MagneticSystem®



HYPERWHITE EFFECT

List Ref: page 97

ATLANTE

BY NIGEL COATES

Strong, like the name it bears. Obligated by Zeus to keep the heavens on his shoulders and poetically described in the Odyssey as one of the pillars of the sky, Atlante inspires the contemporary design of this lamp, as tied to the universe as to the forms of superhuman life. Made in Cristalflex® with slight dove gray hues, its terrestrial environment is among books on painting and travel stories, photographs albums and architectural projects.

Forte, come il nome che porta. Costretto da Zeus a tenere sulle spalle l'intera volta celeste e descritto poeticamente nell'Odissea come uno dei pilastri del cielo, Atlante ispira il contemporaneo design di questa lampada, legato tanto all'universo quanto alle forme di vita sovrumane. Realizzata in Cristalflex® con una leggera sfumatura tortora, il suo ambiente terrestre è tra libri di pittura e racconti di viaggio, tra album di fotografie e progetti di architettura



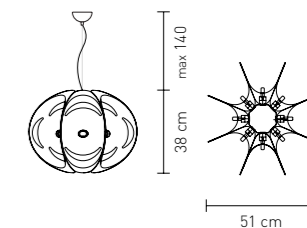
ATLANTE design by Nigel Coates

SUSPENSION

Bulbs E14:
8 X 28W max - Halogen

Made of: Cristalflex®

With: Bulbs Included

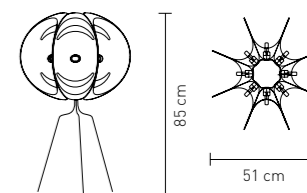


FLOOR-TABLE LAMP

Bulbs E14:
8 X 28W max - Halogen

Made of: Cristalflex®

With: Stainless steel legs
Bulbs Included



FUMÉ

List Ref: page 95

HARRIS

BY FRANCESCO PARETTI

The minimalist rigor of transparent squares meets elegance and warmth of the shades of precious gems. Amethyst, amber, aquamarine and quartz envelop the light diffuser generating a rhythm of interpenetration on which the light dances following a direction that can excite any home or other interior.

Il rigore minimalista di quadrati trasparenti incontra l'eleganza e il calore delle tonalità di preziose gemme. Ametista, ambra, acquamarina e quarzo avvolgono il diffusore luminoso generando un ritmo di compenetrazione su cui la luce danza seguendo una direzione capace di scaldare ogni interior domestico e non.

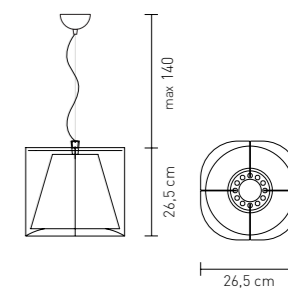


HARRIS design by Francesco Piretti

SUSPENSION

Bulbs E27:
1 X 8W LED Filament or
1 X 75W max - Halogen

Made of: Opalflex® / Cristalflex®/
Polycarbonate



AMETHYST QUARTZ AMBER AQUAMARINE

List Ref: page 92

GIRAFIORE

BY ELODIE LONGO

This splendid layered crown, created by placing petals of Opalflex® next to transparent Cristalflex®, appears to follow wherever the light is pointing – a perfect recreation of the endless game of tag between Sun and sunflower. The result is both softly luminous and naturally diffusing.

La splendida corolla piegata, nata accostando petali di Opalflex® a trasparente Cristalflex®, sembra seguire il punto verso cui la luce è orientata. Ideale per dare forma all'eterno gioco del rincorrersi tra Sole e Girasole. Il risultato è un insieme di morbida luminosità e riflessi naturali.



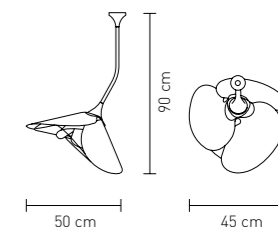
GIRAFIORE design by Elodie Longo

SUSPENSION

Bulbs E27:
1 X 8W LED Filament or
1 X 24W FBG

Made of: Opalflex® Gold /
Cristalflex® Fumé

With: Stainless Steel support
Bulb included

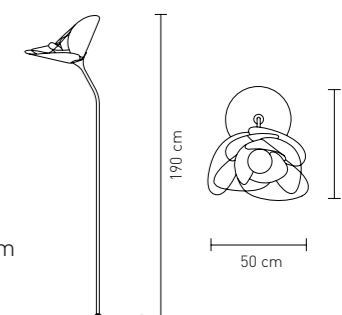


FLOOR LAMP

Bulbs E27:
1 X 8W LED Filament or
1 X 24W FBG

Made of: Opalflex® Gold /
Cristalflex® Fumé

With: Stainless Steel Base and Stem
Bulb included



GOLD/FUMÉ

List Ref: page 93

LAS PALMAS

BY JONAS CLEMENTONI

Two fronds of an exotic palm overlay in a clever combination of folded and printed Opalflex®. If it's a little bit of extra heat you are looking for, this is the perfect addition to an entrance requiring an

exotic flavour.

Tanta voglia di evasione per una forma che si ispira alla struttura di una pianta esotica e con un nome che rimanda a isole da sogno. Un desiderio estivo realizzato in Opalflex® per dare un tocco divertente ma elegante a una stanza lineare e naturalistica.

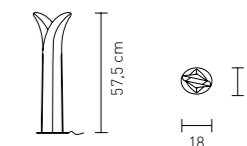


LAS PALMAS design by Jonas Clementoni

SMALL TABLE LAMP

Bulbs E14:
1 X 4W LED Filament or
1 X 40W max - Halogen

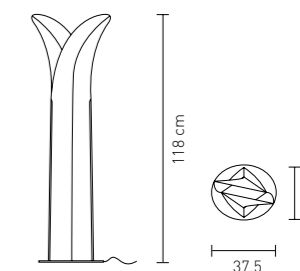
Made of: Opalflex® / Polycarbonate
With: Stainless Steel base and profiles



LARGE FLOOR LAMP

Bulbs E27:
2 X 8W LED Filament or
2 X 60W max - Halogen

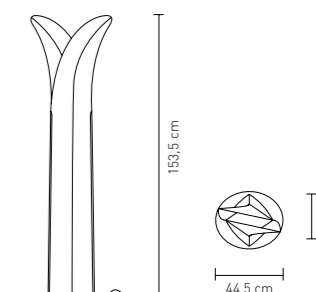
Made of: Opalflex® / Polycarbonate
With: Stainless Steel base and profiles



EXTRALARGE FLOOR LAMP

Bulbs E27:
3 X 8W LED Filament or
3 X 60W max - Halogen

Made of: Opalflex® / Polycarbonate
With: Stainless Steel base and profiles



WHITE

List Ref: page 98

ECSTACITY

BY NIGEL COATES

Elegant, refined and cosmopolitan; a lamp that captures the many voices of truly modern cities where desires and spaces flow in an incongruous harmony. The serigraphic print is composed of quotes from the book of the same name by architect Nigel Coates.

Elegante, raffinata e cosmopolita. Capta tutte le voci di una città ideale, dove desideri e luoghi fisici scorrono in un flusso perfetto. La stampa serigrafica riporta i testi originali dell'omonimo libro di Nigel Coates, accendendone il significato.



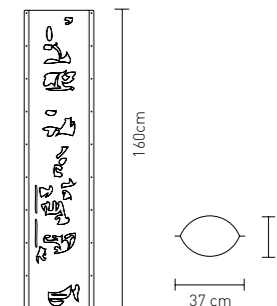


ECSTACITY design by Nigel Coates

FLOOR LAMP

Bulbs E27:
3 X 8W LED Filament or
3 X 75W max - Halogen

Made of: Opalflex®
With: Aluminium Profile
Dimmer



List Ref: page 99

<https://www.instagram.com/orders/slab/>

WATURA ARUTAN

ADAPTABLE
SENSUAL
MYSTERIOUS
INNOVATIVE
ACCESSIBLE
RELIABLE
ASPIRATIONAL
ORIGINAL
RESOURCEFUL
EXPERIMENTAL
SUGGESTIVE

SLAMP:

Made in Italy