

m  i<sup>©</sup>



# ***THE UNEXPECTED WELCOME***

*mooi book 2011*



# LIGHTING



**034**  
RABBIT LAMP



**027**  
NON RANDOM



**053**  
KAIPO



**032**  
HANG



**057**  
LOLITA FLOOR LAMP



**015**  
RAIMOND



**036**  
FRINGE



**036**  
FRINGE



**024**  
NON RANDOM



**032**  
DOUBLE ROUND LIGHT



**054**  
SET UP SHADE



**032**  
DOUBLE SHADE



**075**  
HORSE LAMP



**040**  
CLUSTER LAMP



**039**  
TREE LAMP



**057**  
LOLITA



**044**  
PAPER CHANDELIER



**068**  
RANDOM LIGHT



**022**  
BRAVE NEW WORLD XL



**032**  
OVAL LIGHT



**062**  
EMPEROR



**015**  
RAYMOND



**032**  
TRIX



**049**  
SMOKE CHANDELIER



**032**  
SQUARE LIGHT



**032**  
TUBE



**020**  
BRAVE NEW WORLD



**072**  
ICON



**048**  
PAPER TABLE LAMP



**017**  
RAYMOND ZAFU



**078**  
LIGHT SHADE SHADE  
FLOOR LAMP



**064**  
EMPEROR TABLE LAMP



**032**  
ROUND LIGHT



**028**  
DEAR INGO



**057**  
LOLITA TABLE LAMP



**066**  
RANDOM LIGHT



**047**  
PAPER FLOOR LAMP



**077**  
ROUND & SQUARE BOON



**084**  
MIYAKE



**050**  
DANDELION



**078**  
LIGHT SHADE SHADE



**036**  
FRINGE



**071**  
RANDOM FLOOR LAMP



**032**  
SQUARE LIGHT



**062**  
EMPEROR FLOOR LAMP

# ACCESSORIES



**104**  
FOAM BOWL



**090**  
DELFT BLUE



**111**  
FRAME MIRROR



**113**  
THROW



**109**  
BLOW AWAY VASE



**120**  
PAPER MIRROR



**123**  
CARPETS



**104**  
SPONGE VASE



**098**  
ELEMENTS



**097**  
SOFT CLOCK

# STORAGE



**189**  
PAPER CUPBOARD



**176**  
OBLIQUE



**181**  
CITY



**184**  
PAPER CABINET



**178**  
OBLIQUE



**183**  
PAPER WARDROBE



**187**  
PAPER BUFFET



**103**  
BIG BOLD



**155**  
CONTAINER BOWL



**114**  
"THE KILLING OF  
THE PIGGY BANK"



**125**  
PAPER SCREEN



**117**  
FRAME



**105**  
EGG VASE

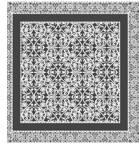

**123**  
CARPETS



**153**  
CONTAINER VASE



**113**  
THROW



**090**  
DELFT BLUE

# TABLES



**171**  
5 O'CLOCK TABLE



**134**  
BALLS



**165**  
TWO TOPS TABLE

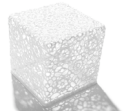

**160**  
CROCHET TABLE



**166**  
PAPER TABLE



**133**  
PIG TABLE



**171**  
5 O'CLOCK TABLE



**157**  
AVL TABLE



**158**  
CHESS TABLE



**162**  
TWO TOPS SECRETARY



**169**  
PAPER SIDE TABLE



**137**  
CONTAINER TABLE

# SEATERS



**252**  
BOUTIQUE XL  
SOPHY



**208**  
MANNEQUIN FEMININE



**229**  
BOTTONI SHELF



**151**  
CONTAINER STOOL



**261**  
BOUTIQUE XL LACE



**219**  
VICA



**264**  
BOUTIQUE TRAVIS



**250**  
BOUTIQUE BLANKET



**259**  
BOUTIQUE CHA-  
MELEON



**193**  
MONSTER ARM CHAIR



**254**  
BOUTIQUE NEW  
YORK



**215**  
AVL SHAKER STOOL



**265**  
BOUTIQUE XL  
PAUSE



**245**  
BOUTIQUE FEET



**208**  
MANNEQUIN  
BLACK JESTER



**202**  
SMOKE CHAIR



**254**  
BOUTIQUE LEATHER



**246**  
BOUTIQUE  
LEATHER



**250**  
BOUTIQUE BLANKET



**251**  
BOUTIQUE JESTER





**265**  
BOUTIQUE XL  
EASY RIDER



**193**  
MONSTER CHAIR



**260**  
BOUTIQUE COCO



**254**  
BOUTIQUE  
MANGA



**224**  
BOTTONI



**253**  
BOUTIQUE DADDY



**231**  
CLIP CHAIR



**233**  
PARENT CHAIR



**222**  
BARBARELLA



**201**  
SMOKE DINING  
ARMCHAIR



**256**  
BOUTIQUE SILVER



**207**  
V.I.P. CHAIR



**227**  
BOTTONI SLIM



**196**  
5 O'CLOCK CHAIR



**254**  
BOUTIQUE SILVER



**258**  
BOUTIQUE KIMONO



**237**  
CORKS



**263**  
BOUTIQUE MEDALLION



**213**  
CARBON CHAIR



**268**  
BOUTIQUE CHAMELEON



**219**  
VICA



**254**  
BOUTIQUE JESTER



**261**  
BOUTIQUE  
MANGA



**267**  
BOUTIQUE DIARY



**239**  
DICKIE

# INDEX

## STAIN COLOURS



Natural Lacquer



Black stained



White wash

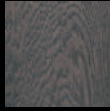

Wenge



Natural Oak



Ochre



Zebrano

## RAL COLOURS



White RAL 9016



Black RAL 9005



Red RAL 3020



Orange RAL 2004



Brown RAL 8017



Pink RAL 3015



Grey RAL 7036



Grey RAL 7044



Ocean Blue  
RAL 5020



Silver Grey  
RAL 9006

## FABRICS TEXTILES



Grey



White



Black

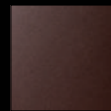

Graphite

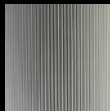

Kaipo  
Light Grey



Kaipo  
Dark Grey



Kaipo  
Red



Kvadrat  
Divina  
Melange 180



Kvadrat  
Divina  
Melange 120



Kvadrat  
Divina  
Melange 681



Kvadrat  
Divina  
Melange 260

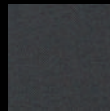

Kvadrat  
Field  
192



Kvadrat  
Field  
132

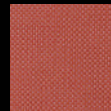

Kvadrat  
Field  
662

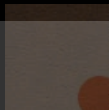

Skai  
Brown

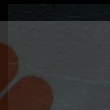

Skai  
Black



Skai  
Green



Skai  
White





*Anthony Kleinepier*



*Maarten Baas*



*Studio Job*



*Front*



*Joel Degermark*



*Ross Lovegrove*



*Neri & Hu*



*Raimond Puts*



*Ron Gilad*



*Piet Boon*



*Nika Zupanc*



*Jurgen Bey*



*Joep van Lieshout*



*Matti Klenell*

*Roderick Vos*

*Arihiro Miyake*

*Fresh West*



*Simone Pullens*

*Marcel Wanders*

*Jaime Hayon*

*Jasper Morrison*

*Edward van Vliet*



*Blasius Osko & Oliver Deichman*

*Kiki van Eijk*

*Richard Hutten*

*Bertjan Pot*



**LUSTRO GRAD**  
ОПТОВЫЕ ПРОДАЖИ СВЕТИЛЬНИКОВ

BRAVE NEW WORLD LAMP  
BRAVE NEW WORLD XL  
CLUSTERLAMP  
DANDELION  
DEAR INGO BLACK  
DEAR INGO WHITE  
DOUBLE ROUND LIGHT  
DOUBLE SHADE  
DOUBLE SQUARE LIGHT  
EMPEROR  
FRINGE  
HANG  
HORSE LAMP  
ICON  
KAIPO  
LIGHT SHADE SHADE  
LONG LIGHT  
LOLITA  
MIYAKE  
NON RANDOM  
OVAL LIGHT  
PAPER CHANDELIER L  
PAPER CHANDELIER XXL  
PAPER FLOOR LAMP  
PAPER TABLE LAMP  
RAIMOND  
RAIMOND ZAFU  
RABBIT LAMP  
RANDOM LIGHT  
RANDOM LIGHT LED  
ROUND BOON  
ROUND LIGHT  
SET UP SHADE  
SMOKE CHANDELIER  
SQUARE BOON  
SQUARE LIGHT  
TREE LAMP  
TRIX  
TUBE

# LIGHTING





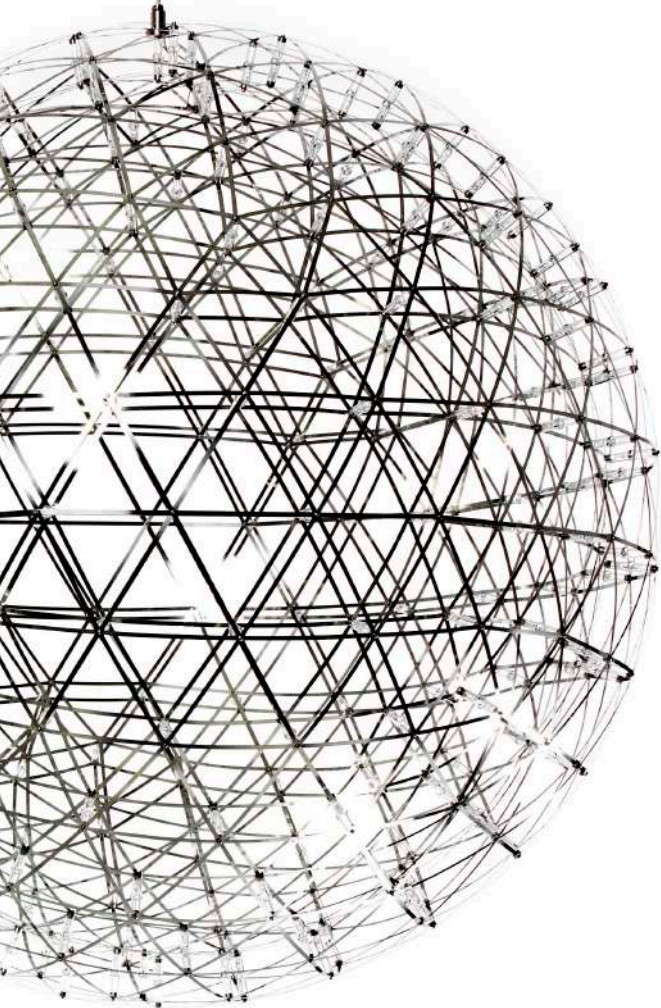

# RAIMOND

**RAIMOND PUTS IN ASSOCIATION WITH OX-ID 2007**

material: stainless 'spring steel'

ø43cm, ø61cm, ø89cm

(Raimonds for USA and CA market have black cable instead of transparent cable)

**in stock**



89cm | 35"

61cm | 24"

43cm | 16.9"





# RAIMOND ZAFU

**RAIMOND PUTS IN ASSOCIATION WITH OX-ID 2007**

material: stainless 'spring steel'

(Raimonds for USA and CA market have black cable instead of transparant cable)

**in stock**



75cm | 29.5"



30cm | 12"

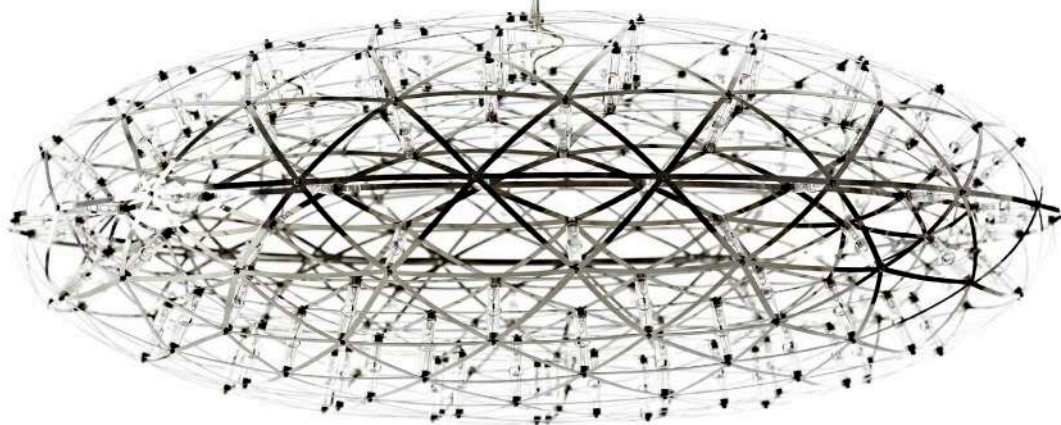

The Raimond lamp is based on the pure beauty of mathematics. Its creator, Raimond Puts, has been busy developing the concept of this extraordinary lamp for great part of his life.

It all started with the discovery of the geometric shape of a football that brought him to consider round shapes formed by triangles. Hundreds of stainless steel strips intersect creating triangles that converge into a perfectly round globe. The poetry of a sphere composed of straight lines.

His love for the absolute and fundamental sciences inspired questions that tickled him for years, until the Raimond lamp as we know it was finalized and became part of the Moooi collection in 2009. Authentic and extremely complex at the same time.

The Raimond lamp: a perfect sphere of mathematical ingredients punctuated by tiny LED lights. Looking at the lamp feels like staring into the soft glow of a starry night. Into the essence.

127cm | 50"

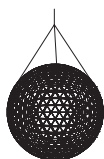

163cm | 64.2"

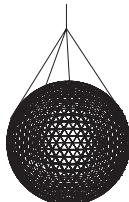

199cm | 78.3"

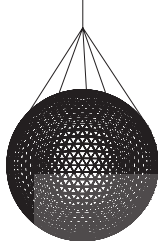

# RAIMOND

## RAIMOND PUTS 2008 IN ASSOCIATION WITH OX-ID

material: stainless 'spring steel'

ø 127cm, ø 163cm, ø 199cm

(Raimonds for USA and CA market have black cable instead of transparent cable)

on commission



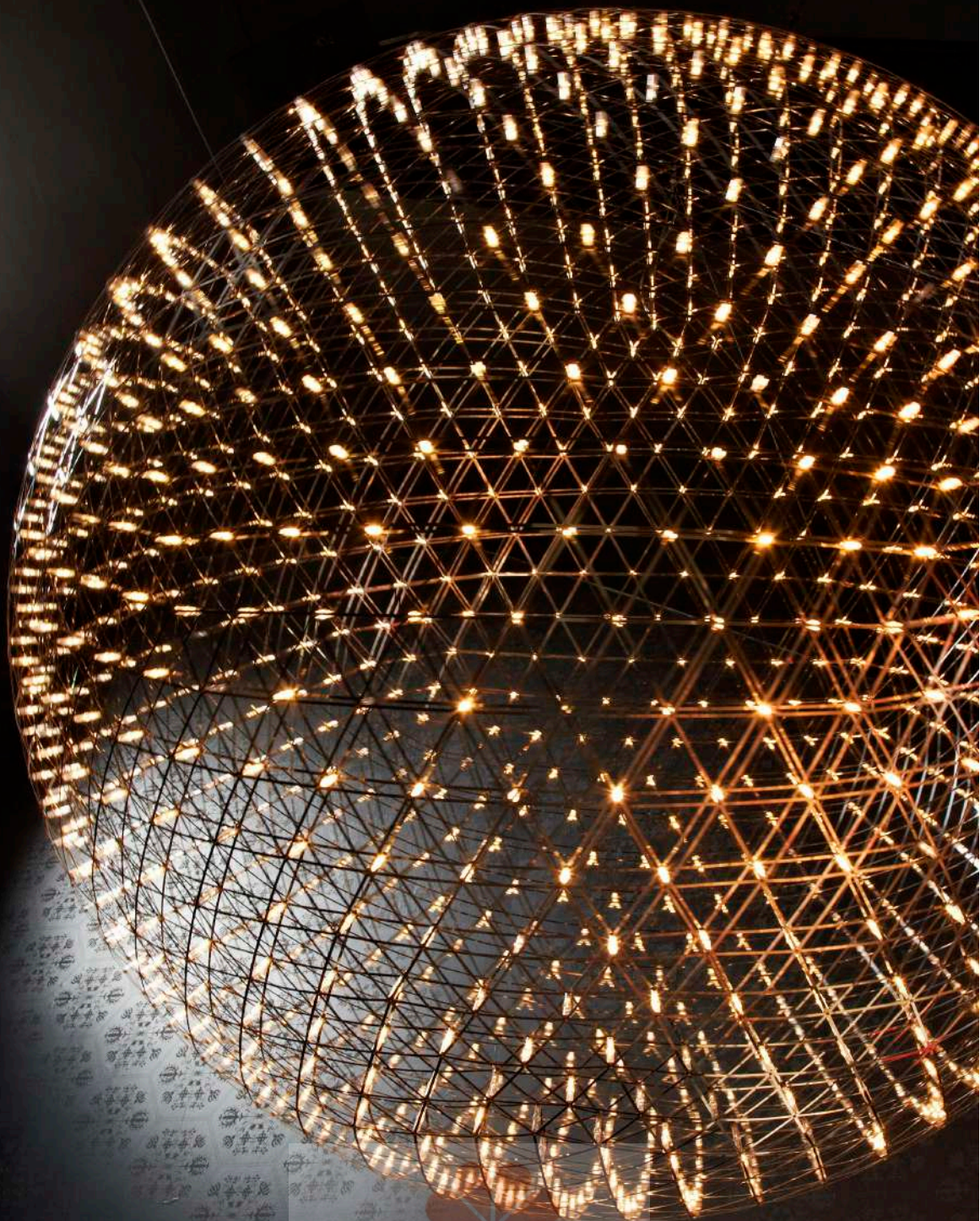



70cm | 27.6"



180cm | 70.9"

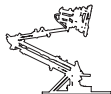

110cm | 43.3"

## **BRAVE NEW WORLD LAMP** **FRESH WEST 2008**

material: oak frame and cast iron balancing weights

**in stock**



*The Brave New World Lamp started as a concept piece of random thought-initiated construction. Inspired by the traditional Far Eastern bamboo scaffolding. The Brave New World Lamp was developed without a design or plan in place. However each piece of wood is carefully notched and pegged together to form an integral part of the overall mechanical mechanism. The limitations of using small pieces of wood to create a large form allowed the design process to be as responsive as possible. Much like a sculptures' relationship to their material.*



# BRAVE NEW WORLD XL



**XL**

160cm | 63"

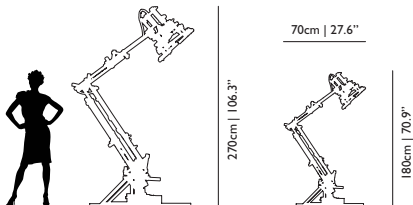

**FRESHWEST 2010**

material: oak frame and cast iron balancing weights  
can be positioned at variable heights  
**on commission**





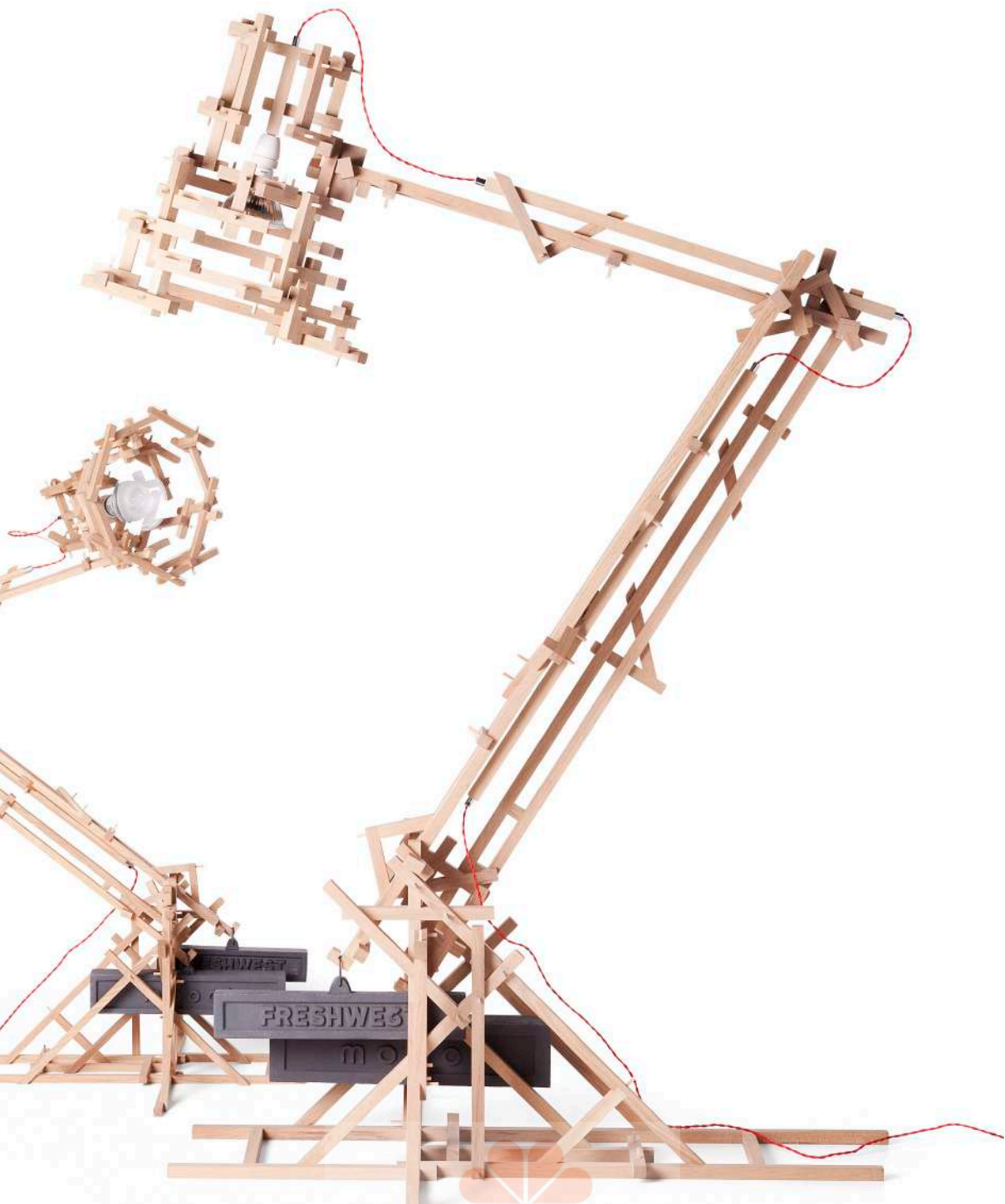



71cm | 28"



48cm | 18.9"



70cm | 27.6"



54cm | 21.3"

## NON RANDOM

### BERTJAN POT 2007

material: fibreglass soaked in epoxy resin, powder coated aluminium cap

material reflector: shiny anodized aluminium

colour: black or white

**in stock**



NON RANDOM

ELEMENT 007

PIG TABLE

BOUTIQUE DOUBLE SEATER JESTER

CHESS TABLE

LOLITA TABLE LAMP

Меню 007



LUSTRO GRAD

ОПТОВЫЕ ПРОДАЖИ СВЕТИЛЬНИКОВ



**BRAVE NEW WORLD  
SET UP SHADE  
CONTAINER TABLE  
CONTAINER BOWL & BASE**



# NON RANDOM

## BERTJAN POT 2007

material: fibreglass soaked in epoxy resin,

powder coated aluminium cap

material reflector: powder coated aluminium

colour: black or white

**in stock**



71cm | 28"



48cm | 18.9"



70cm | 27.6"



54cm | 21.3"





min. 80cm max. 240cm |  
min. 31.5" max. 94.5"

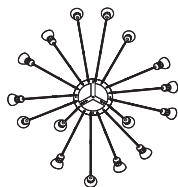

50cm | 19.7"

# DEAR INGO

## RON GILAD 2010

material: powder coated steel

features 16 lamp holders

colour: black or white

**in stock**

*Direct the spots in the most functional crooked way or find your optimum balance.*







min. 80cm max. 240cm |  
min. 31.5" max. 94.5"

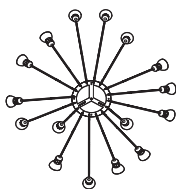

50cm | 19.7"





# DEAR INGO

## RON GILAD 2003

material: powder coated steel

features: 16 lamp holders

colour: white or black

**in stock**

*Direct the spots in the most functional crooked way or find your optimum balance.*



ALL LAMPS ON THIS PAGE ARE



## ROUND LIGHT & SQUARE LIGHT

Marcel Wanders 1999

material: pvc/viscose laminate on metal frame,

chromed steel pendant

colour: white, black or graphite

**in stock**

65cm | 25.6"



20cm | 7.9"

## TUBE

Marcel Wanders 1998

material: pvc/viscose laminate on metal frame,

chromed steel pendant

colour: white

**in stock**



60cm | 23.6"

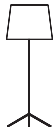

160cm | 63"

## DOUBLE SHADE

Marcel Wanders 1998

material base: powder coated steel

material shade: pvc/viscose

laminate on metal frame

colour: white, black or graphite

**in stock**

30cm | 11.8"



122cm | 48"

## TRIX

Marcel Wanders 1998

material: pvc/viscose laminate on metal frame,

chromed steel pendant

colour: white

**in stock**





60cm | 23.6"



### HANG

Marcel Wanders 1999

material: pvc/viscose laminate on metal

frame, chromed steel pendant

colour: white, black or graphite

**in stock**

105cm | 41.3"

61.5cm | 24.2"



105cm | 41.3"

61.5cm | 24.2"



### LONG LIGHT & OVAL LIGHT

Marcel Wanders 1999

material: pvc/viscose laminate on metal frame,

chromed steel pendant, features 2 lamp holders

colour: white, black or graphite

optional: special ceilingcap with double cord output

**in stock**

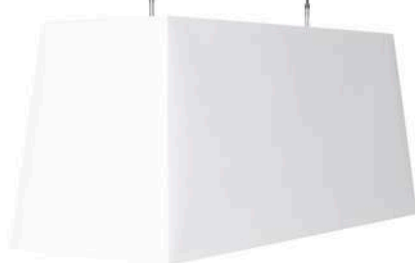

42cm | 16.5"



43cm | 16.9"



### DOUBLE SQUARE LIGHT & DOUBLE ROUND LIGHT

Marcel Wanders 1999

material: pvc/viscose laminate on metal frame

colour: white, black or graphite

**in stock**







28.5cm | 11.2"



54cm | 21.3"

## RABBIT LAMP

### FRONT 2006

material rabbit: fibreglass

material shade: pvc/viscose laminate on metal frame, closed top  
colour: black

The Rabbit Lamp is one of a three piece collection of animal furniture which also includes a life-sized Horse Lamp and Pig Table. A perfect guest for a Mad Hatters tea party.

**in stock**



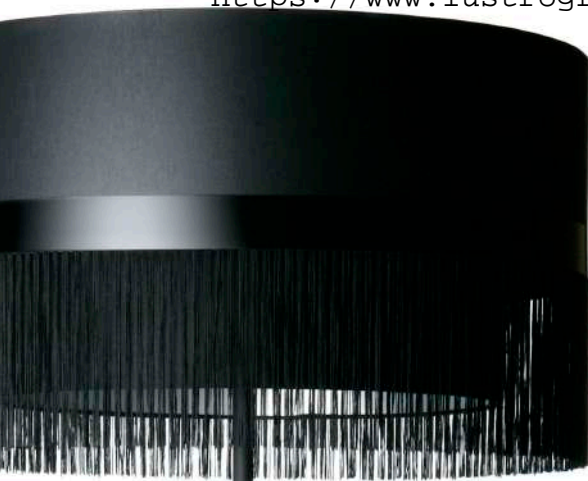

## FRINGE 1, 2, 4, 5 & 6

**EDWARD VAN VLIET 2003**

*material: pvc/viscose laminate on metal frame, chromed steel pendant*

*colour: white*

*fringe 1 & 5: black or white*

**in stock**



**LUSTROGRAD**  
ОПТОВЫЕ ПРОДАЖИ СВЕТИЛЬНИКОВ

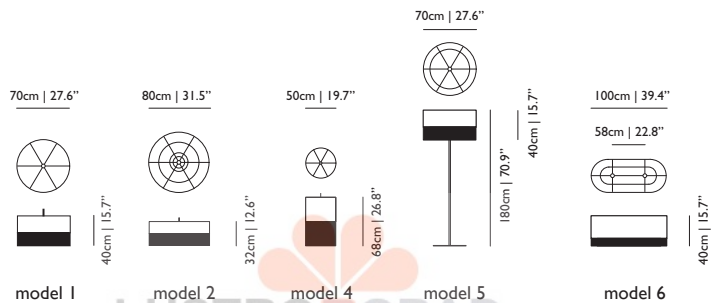



**TREE LAMP, ZEBRANO**  
**OBLIQUE BIG**  
**BOUTIQUE XL TRIPLE MANGA**  
**CORKS**



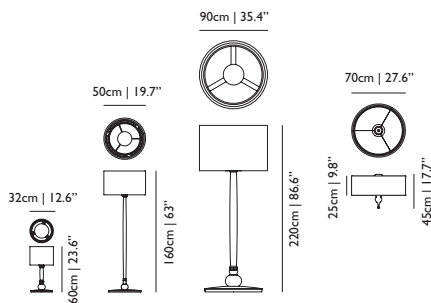

## TREE LAMP

**MOOOI WORKS 2008**

material: zebano and oak structures, glass diffuser

colour: natural oak, zebano or ochre oak

**in stock**



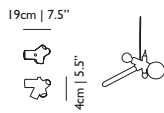

# CLUSTERLAMP

**JOEL DEGERMARK 2004**

*material: fibre reinforced polybutylene terephthalate (PBT)*

*features 5 lamp holders*

*colour: white*

*light bulbs not included*

*Create your own Clusterlamp composition by adding the most exotic light bulbs you can find!*

*Exploring new possibilities with a whole spectrum of lighting combinations.  
The 'Clusterlamp' from Joel Degermark evokes experimentation with ambient expression.*

**in stock**







**D**

# CLUSTERLAMP LIGHT BULBS

**TO GET YOU STARDED!**

*can be ordered separately  
in stock*



**A**



**B**



**C**

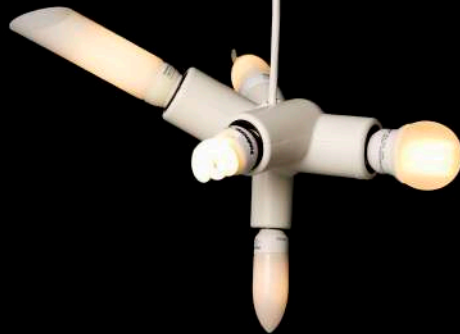

## **ENERGY Clusterlamp**

*Moooi fixtures developed before 2008 have been designed for use with incandescent light sources.  
Due to the new European regulations these will not be available in the European Union in the near future.  
The EU's objective is to save energy and help the market push more efficient CFL & LED lightbulbs.*

*Create your own Energy Clusterlamp composition by adding the most exotic energy-saving lightbulbs you can find!*



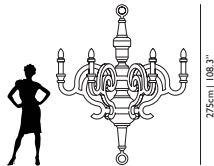
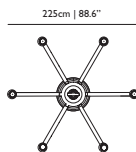

90cm | 35.4\"/>



101.5cm | 40\"/>

# PAPER CHANDELIER L & XXL

## STUDIO JOB 2005

material: wood and cardboard, finished with paper and polyurethane (PU) lacquer

Paper Chandelier L features 5 lamp holders

installation of the Paper Chandelier XXL requires a trained professional

Paper Chandelier XXL features 6 lamp holders

colour: white

A sturdy structure wrapped in the visual softness and innocence of paper.

**in stock**

**PAPER CHANDELIER L**  

**PAPER CHANDELIER XXL**  (Not available for North American market)



**PAPER CHANDELIER L**





# PAPER FLOOR LAMP

## STUDIO JOB 2005

*material: wood and cardboard, finished with paper and polyurethane (PU) lacquer*

*colour: white*

*A sturdy structure wrapped in the visual softness and innocence of paper.*

**in stock**





37cm | 14.6"



84cm | 33.1"



## PAPER TABLE LAMP STUDIO JOB 2008

*material: wood and cardboard, finished with paper and polyurethane (PU) lacquer  
features 2 lamp holders  
colour: white*

*A sturdy structure wrapped in the visual softness and innocence of paper.*

**in stock**



65cm | 25.6"



55cm | 21.7"



## SMOKE CHANDELIER MAARTEN BAAS 2002

material: burnt wood, finished with epoxy resin  
colour: black

*Furniture finished with fire.  
The beauty and character of burnt wood is now captured in a long lasting material, creating  
the strange sensation of burnt furniture.*  
**in stock**





**BALLS TABLE**  
**DELFT BLUE NO. 6**  
**DANDELION FLOORLAMP**





80cm | 31.5"



55cm | 21.7"



170cm | 66.9"

# DANDELION

**RICHARD HUTTEN 2004**

material: powder coated aluminium, chromed steel pendant and (only in CE version) textile covered cord

colour: white

**in stock**



True to its name, Dandelion was initially inspired by the plant that creates the famous and poetic 'dandelion snow' of fuzzy, cotton-like seeds when a gush of wind blows on it.

The lamp transmits an explosive feeling of energy in motion, reaching towards us from its centre. Striking and pure self-generated energy to lighten up and blow away the heaviness of everyday life.

Dandelion is truly a breath of fresh air.





37cm | 14.6"



## KAIPO

**EDWARD VAN VLIET 2001**

material base: silvered mouth blown glass  
material shade: pleated fabric in powder coated steel frame  
colour shade: light grey, dark grey or red

Every base is mouth blown and unique,  
every shade is based on airfilter technology  
the ultimate connection between craftwork  
and industry.  
**in stock**



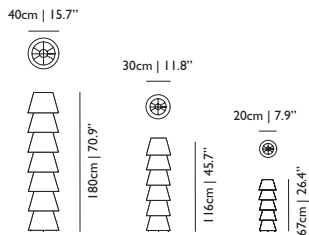

## SET UP SHADE MARCEL WANDERS 1989

material: pvc/viscose laminate on metal frame

colour: white

Exploring the boundaries within type-forms Marcel Wanders presents the 'Set Up Shades' for this intriguing collection.

**in stock**









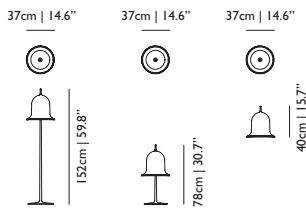
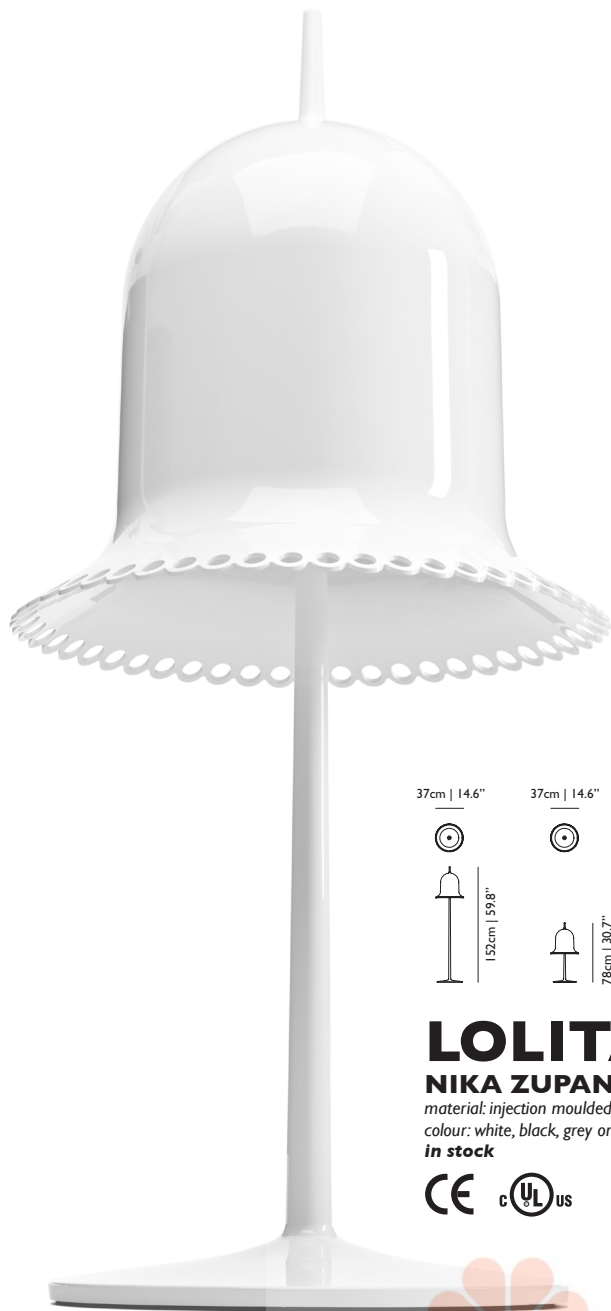

# LOLITA

## NIKA ZUPANC 2008

material: injection moulded ABS shade, polyurethane base  
colour: white, black, grey or pink (inside shade pearle white)

**in stock**





## “WHO IS AFRAID OF PINK?.....”

*...My imagination chases female archetypes intentionally. Frivolous, even naïve objects are my favorite victims. And when, during such a process, I manage to be creative in an evidently reserved way, I then touch the purest meaning of my work and frivolity becomes timeless elegance. Lolita is here to play with your emotions. She is here to break your everyday routine.”*





**SALONE DEL MOBILE 2010**

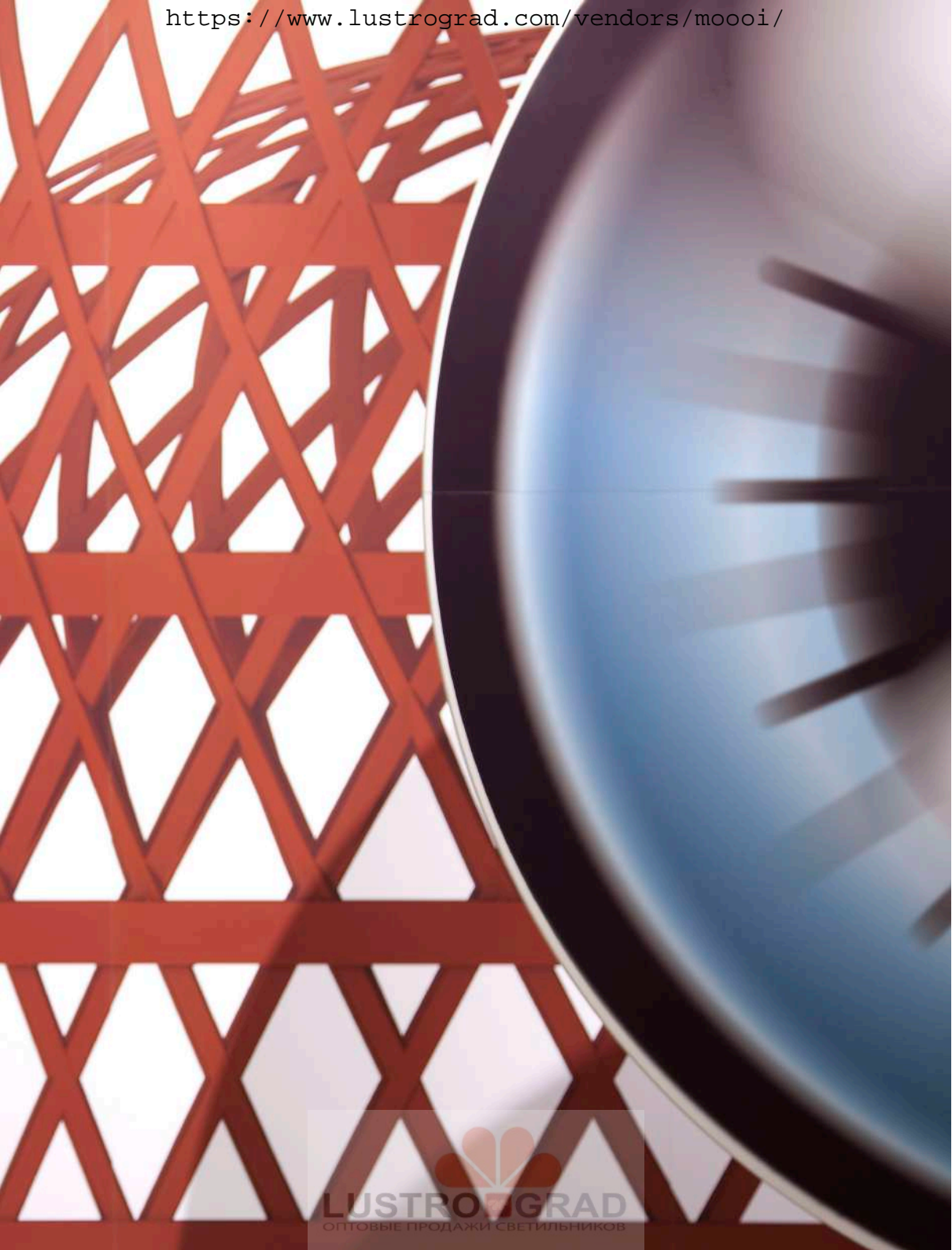

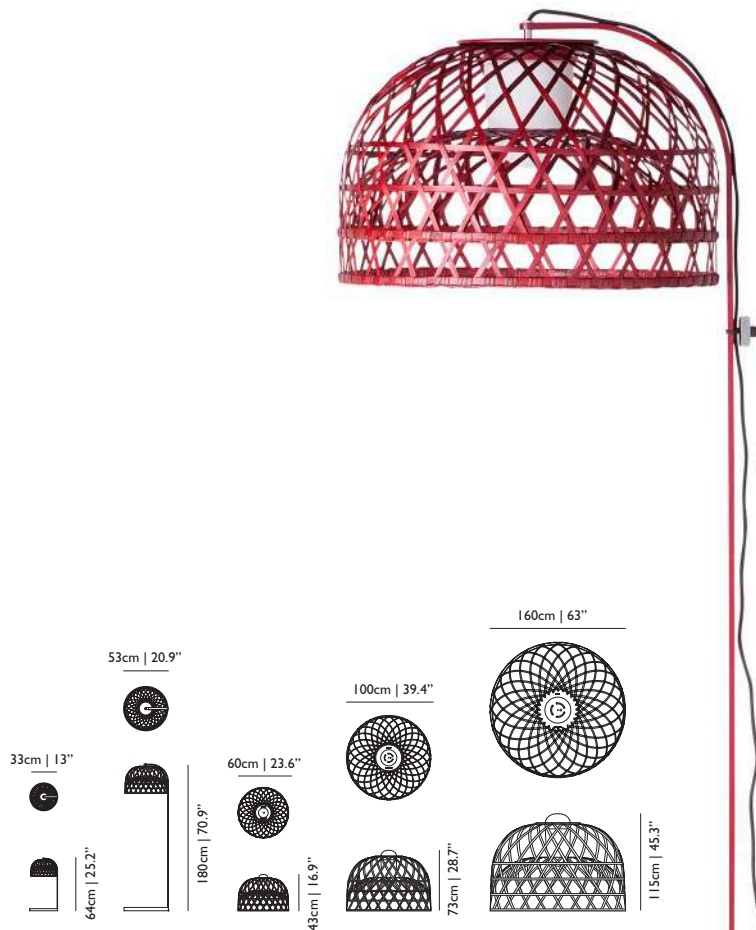

# EMPEROR

## NERI & HU 2009

material: bamboo rattan cage and glass diffuser  
zamac base with steel frame for the floor and table lamp, table lamp & floor lamp are dimmable

colour: black or red

**in stock**

**ø 160cm on commission**

Each cage is hand woven and therefore has a unique character.





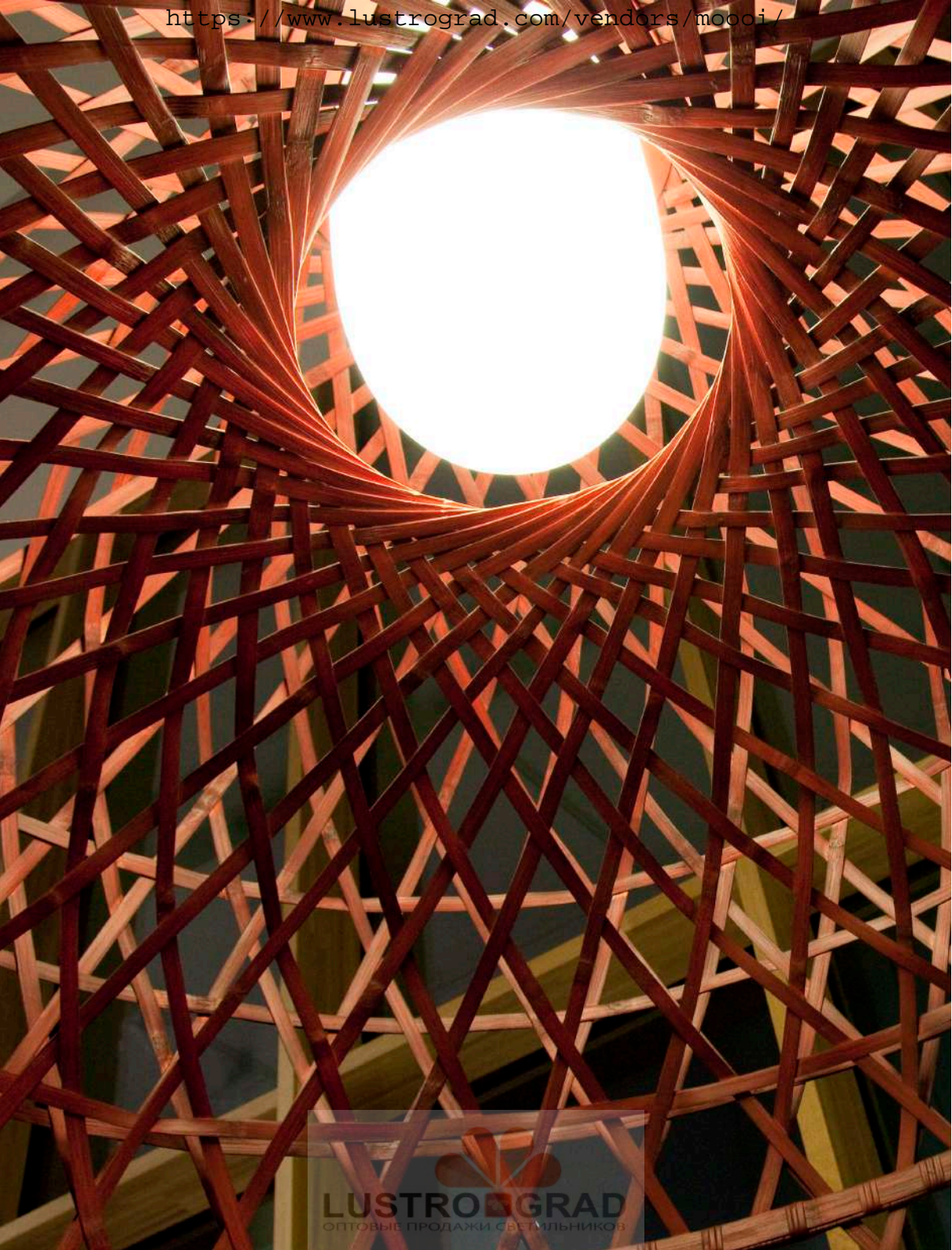



# EMPEROR

## NERI & HU 2009

*material: bamboo rattan cage and glass diffuser*

*zamac base with steel frame for the floor and table lamp, table lamp & floor lamp are dimmable*

*colour: black or red*

*Each cage is hand woven and therefore has a unique character.*





### **EMPEROR Ø60 V.I.P. CHAIR DOUBLE SQUARE LIGHT**

*This oversized light was inspired by a made-believe folklore story of an Asian emperor & a beautiful nightingale... Once upon a time an Asian emperor was given a nightingale as a gift. The bird was so beautiful and sang in such a bewitching way that the emperor fell immediately in love with it and decided to keep it forever by his side. So the nightingale was put in a beautiful, majestic cage in the imperial chambers & became the delight of the emperor's days... Neri & Hu took on a modern translation of this story and produced a collection of pendant/floor/desk lamps in stained woven bamboo.*

*The poetics of an emperor's life, a life no longer relevant in today's world, can be abstracted in the form of an object such as the light. The use of hand-crafted bamboo weaving in an industrial product creates an elegant yet uncanny design statement. A lamp so particular & majestic that it could become your personal nightingale... forever by your side to brighten up your days.*

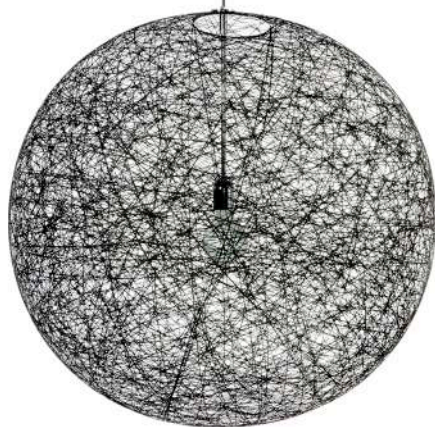

50cm | 19.7"



80cm | 31.5"

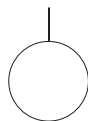

105cm | 41.3"

# RANDOM LIGHT

## S, M & L

### BERTJAN POT 2001

material: fibreglass soaked in epoxy resin, chromed steel pendant

colour: black or white

**in stock**







50cm | 19.7"



80cm | 31.5"

## **RANDOM LIGHT LED, SMALL & MEDIUM BERTJAN POT 2010**

*material: fibreglass soaked in epoxy resin, matt chromed pendant  
colour: black or white*

*Dimmable LED*

**in stock**



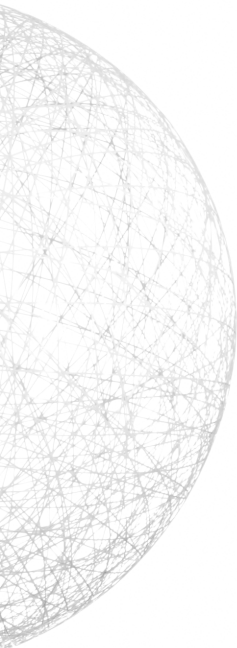

## **RANDOM LIGHT LED!!!**

*Warm and durable lighting comes from the integrated LED light source with opal glass diffuser. For extra comfort the Random LED is equipped with Mood dimming, creating a warmer light color when dimming.*

*In this new version of the product a LED pendant becomes part of the Random Light, creating a long-lasting energy saving light output. Combining a playful design with an environmentally friendly technology. A killer combination.*

**LUSTROGRAD**  
ОПТОВЫЕ ПРОДАЖИ СВЕТИЛЬНИКОВ

*The Random Light is the ideal 'light' solution to furnish any space.*

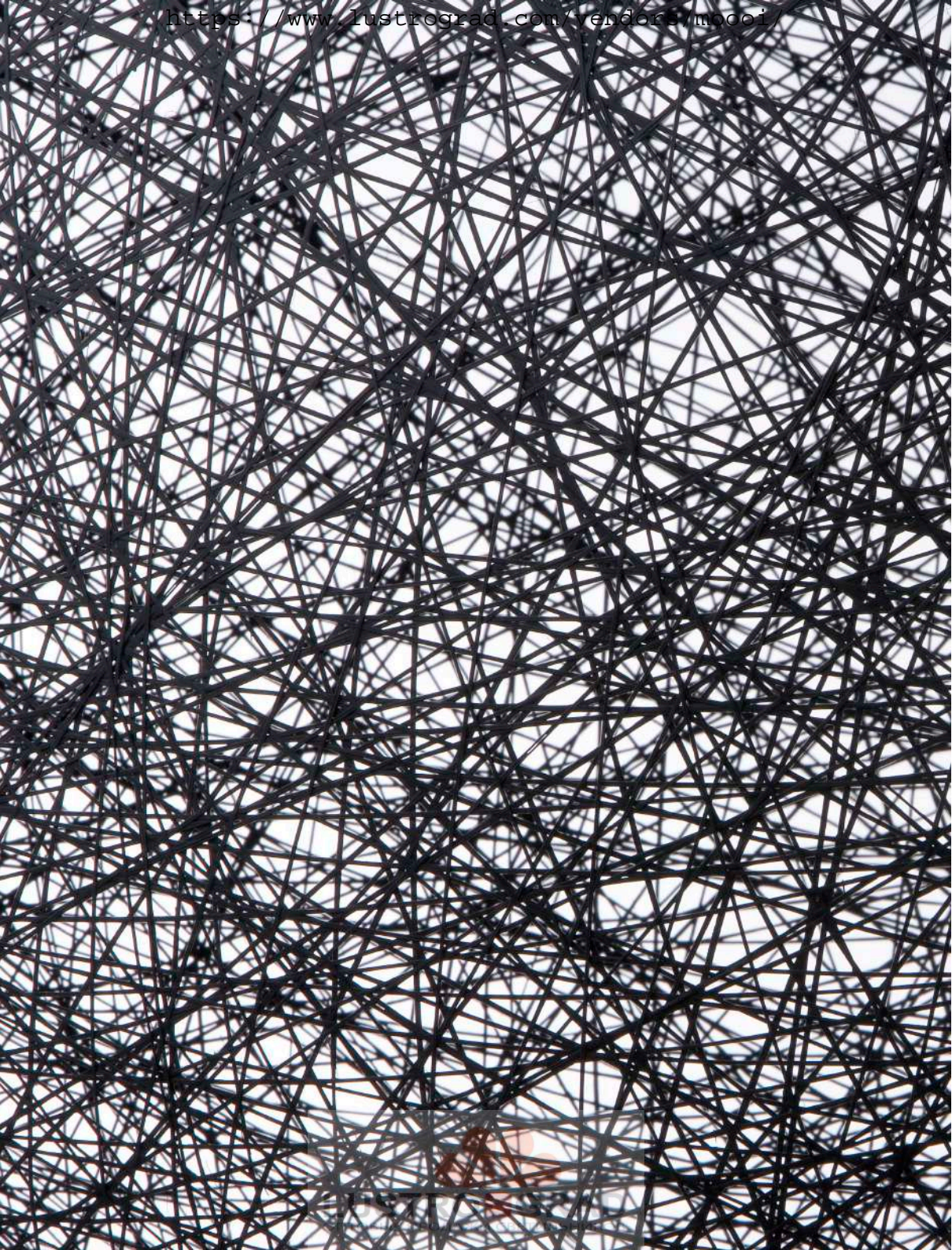



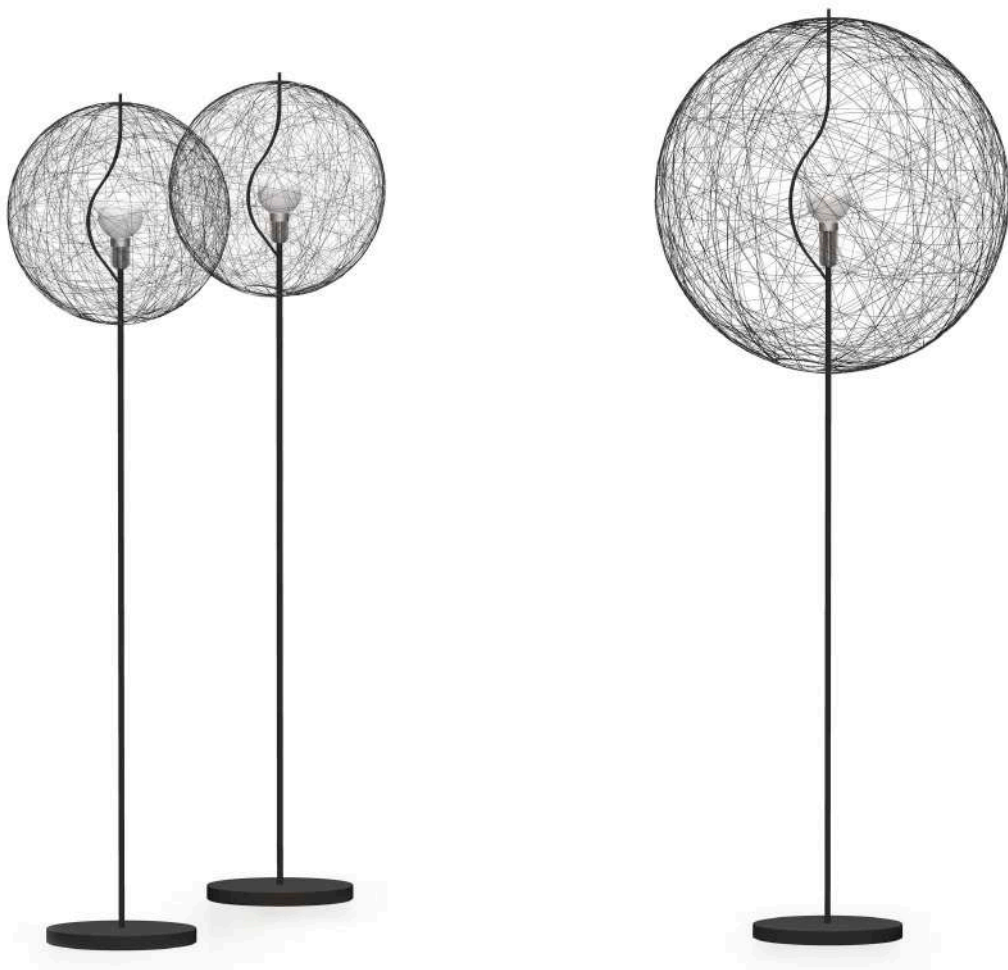

## RANDOM LIGHT **LED** FLOORLAMP SMALL & MEDIUM BERTJAN POT 2010

material: fibreglass soaked in epoxy resin, matt chromed steel pendant

materials (base): matt chromed steel base (white),

semi gloss black powder coated base (black)

matt aluminium heat sink and opal glass diffuser

colour: white (with chromed base) or black

**in stock**

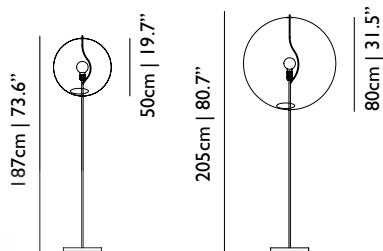

dare to  
touch!  
icon shade  
is as soft as  
velvet...

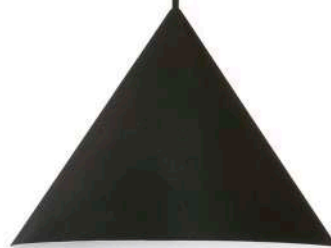
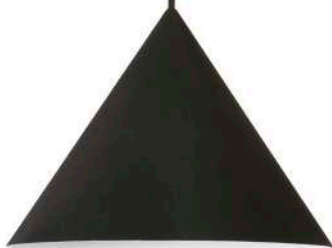

# ICON Ø40 & Ø60

**MATTI KLENELL 2007**

material outside: spun aluminium, flocked

material inside: spun aluminium, powder coated flocked cord and canopy

colour: black flock and white reflector

*"Icon is the Lamp that you come to think of when you can't think of any more lamps. Just like my first rough sketch it is both tactile and brutal - a flat, two dimensional triangle added to a cable or a pole. An everyday memory", Matti Klenell.*

*The Icon shade is as soft as velour.*

**in stock**



40cm | 15.7"



60cm | 23.6"



**HORSE LAMP**  
**NON RANDOM LIGHT**  
**BOUTIQUE TRIPLE SEATER LEATHER**  
**CARPET MODEL 06**



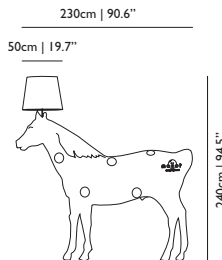

# HORSE LAMP

## FRONT 2006

material horse: fibreglass

material shade: pvc viscose laminate on metal frame, closed top

colour: black

**in stock**



*Nature in all its forms and shapes has always been a source of inspiration for the design world. We have all seen decorative animal objects of different kinds and shapes, although hardly ever in real-life size.*

*The Horse lamp, Pig table and Rabbit lamp by Front are faithful to the true dimensions of the animals bringing a touch of nature in fairytale style and genuine madness. By rejecting abstraction and taking inspiration from living creatures they deliver a powerful emotive content that never fails to elicit a strong response from onlookers. Who wouldn't want a horse or a rabbit to light up their home or a pig to serve their guests?*

**Furniture to fall in love with at first sight or hate forever.**





# SQUARE BOON & ROUND BOON

## PIET BOON 2002

material: pvc/viscose laminate on metal frame, chromed steel pendant

material diffuser: pvc/viscose laminate

standard delivered with 1 lamp holder

optional: 3-way lamp holder for extra lighting power

colour: white, black or graphite

**in stock**



90cm | 35.4"

95cm | 37.4"

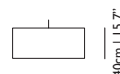
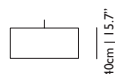

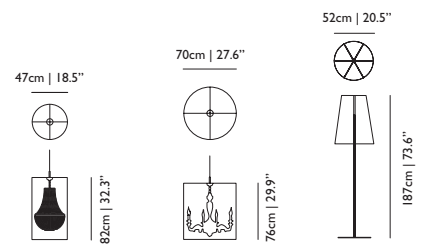

# LIGHT SHADE Ø47 & Ø70 & LIGHT SHADE SHADE FLOOR LAMP

**JURGEN BEY 1999**

material: semi-reflective polyester shade

LSS chandelier Ø47: steel frame with decorative glass beads

LSS chandelier Ø70: bronzed steel frame with decorative glass beads

material LSS Floor Lamp shade inside: pvc/viscose laminate on metal frame

**in stock**







*'Light Shade Shade' is a one way mirror that reflects its environment as well as concealing the chandelier within. When the light is turned on, the 'Light Shade Shade' reveals its unforeseen identity and projects the past beauty that lies within.*

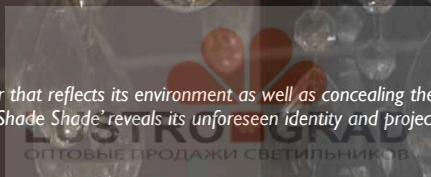



# LIGHT SHADE SHADE Ø95

## JURGEN BEY 1999

*(droog design)*

*material shade: semi-reflective polyester shade*

*LSS chandelier Ø95: bronzed steel frame with decorative glass beads*

**in stock**



95cm | 37.4"



76cm | 29.9"

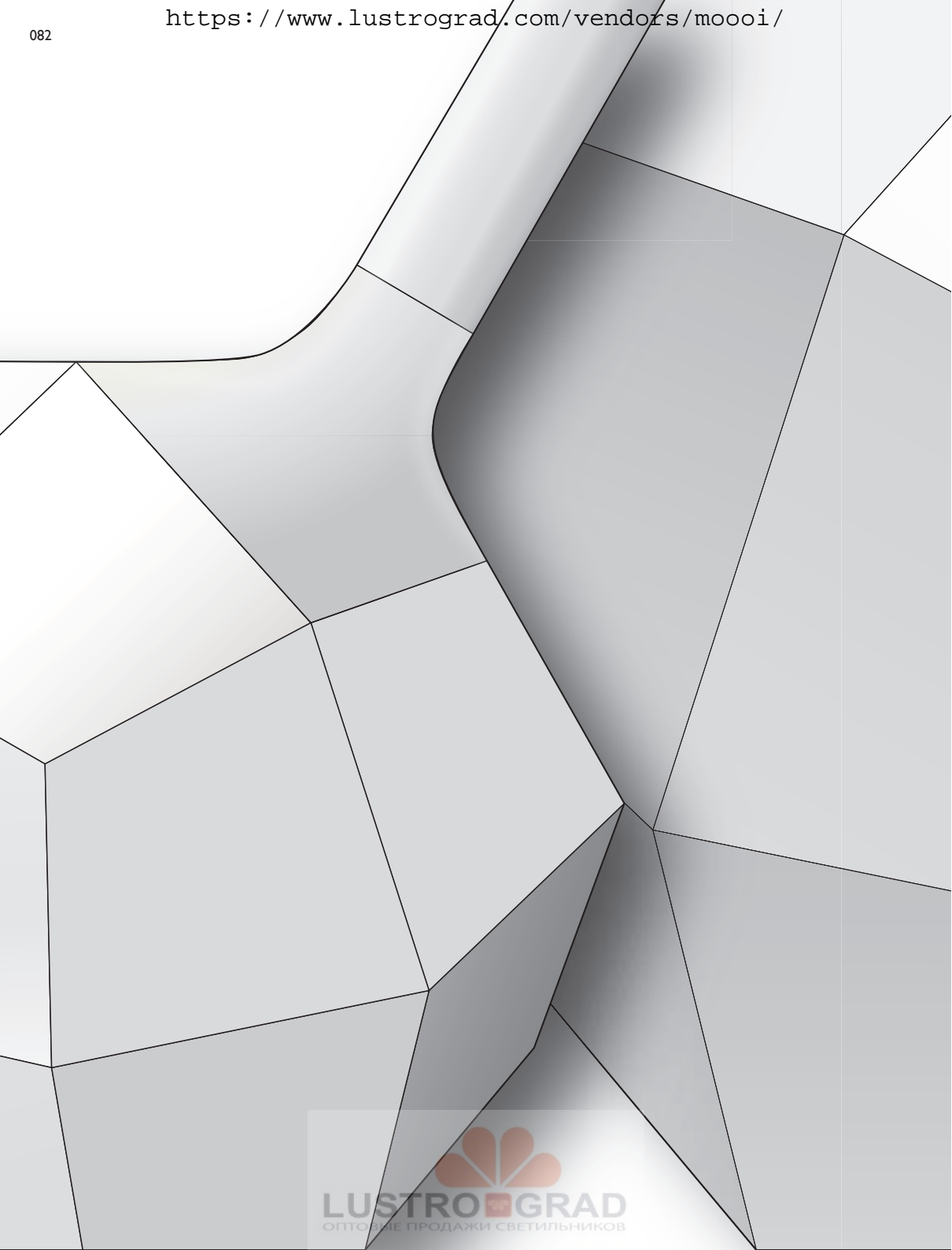





# MIYAKE 60 & 110

**ARIHIRO MIYAKE 2009**

*Miyake 60*

*materials: cast metal base and head, aluminum pole*

*Transparent cord*

*Miyake 110*

*materials: concrete base, cast metal head and aluminum pole*

*Transparent cord*

*Dimmable LED*

**in stock**



 A technical drawing shows the lamps in use. One lamp is positioned next to a chair, and another is next to a desk. Dimensions are provided for both models:
 

- Miyake 60: 42cm | 16.5" (pole height), 80cm | 31.3" (pole length), 10cm | 3.9" (base diameter), 60cm | 23.6" (pole height).
- Miyake 110: 110cm | 43.3" (pole height), 22cm | 8.6" (base diameter), 110cm | 43.3" (pole length).

 The background features the LUSTROGRAD logo and the text "ОПТОВЫЕ ПРОДАЖИ СВЕТИЛЬНИКОВ".

## MIYAKE LAMP

The Miyake Lamp is based on a design that plays with very pure geometrical factors such as weight, surfaces and angles. This simplicity is transmitted to the lines of the design making it unique, appealing and functional at the same time. The result is a lamp that can be placed in several positions without the use of a complex mechanism but simply by re-positioning the base on one of its 24 faces. The lamp's solid base in the shape of a polyhedron and its elegant, dainty looking aluminium stem create a charming contrast of weights and shapes.

Reality and people are known to be essentially simple but carry inside them different faces.

Why not translate that feeling of complex simplicity to a lamp? Miyake is an ode to geometry and life.





BLOW AWAY VASE  
BOLD  
CARPETS  
CONTAINER BOWL  
CONTAINER BOWL BASE  
CONTAINER BOWL TOP  
CONTAINER VASE  
CONTAINER VASE FOOT  
DELFT BLUE  
EGG VASE  
ELEMENTS  
FOAM BOWL  
FRAME  
FRAME MIRROR  
MING VASE  
PAPER MIRROR  
PAPER SCREEN  
SOFT CLOCK  
SPONGE VASE  
THROW JULY  
THROW PANTHEON  
"THE KILLING OF THE PIGGY BANK"

# ACCESSORIES





**DELFT BLUE NO.7**  
**DELFT BLUE NO.9**

# DELFT BLUE

## MARCEL WANDERS 2007

12 different options

material: ceramics

All vases are produced at 'Royal Delft'

This is a dutch company dating back to 1653 and the original producer of the famous Delft Blue ceramics.

The vases are reinterpreting and revitalising Delft Blue, an old Dutch craft, using new ideas for shapes and decoration.

**in stock**



A true example of a new classic collection, Moooi's Delft Blue is a collection of ceramic objects & vases inspired by the traditional Delft Blue pottery.

The production of classic Delftware in the Netherlands reached its peak in the 17th and 18th centuries. It ranged from simple household items to fancy artwork illustrating religious motifs, native Dutch scenes with windmills and fishing boats, hunting scenes, landscapes and seascapes as a reminder of the daily life in the Netherlands.

Marcel Wanders designed a fresh re-interpretation of the classic Dutch craft, using abstract & playful shapes and decorations that translate images from the subconscious instead of everyday scenes. All the vases and ornaments are produced and decorated at 'Royal Delft', a company dating back to 1653 and the original producer of the world famous Delft Blue ceramics.

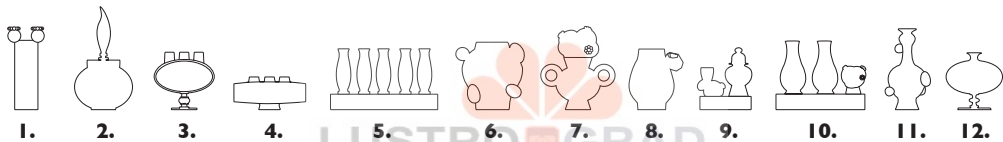









**PAPER TABLE LAMP**  
**SOFT CLOCK**  
**ELEMENT 002**  
**EGG VASE**  
**NON RANDOM LIGHT**





**SOFT CLOCK & DELFT BLUE NO.1**

23cm | 9.1" | 15cm | 5.9"



25cm | 9.8"

# SOFT CLOCK

**KIKI VAN EIJK 2007**

material: ceramics

colour: white & black glaze with gold indicators

gold glaze with gold indicators

silver glaze with silver indicators

battery operated

**in stock**



*A ceramic clock with all the detail and feeling of a soft clock made from fabric. The clock was first stitched in fabric by Kiki herself and moulds are then taken from the fabric model. When ceramic cast are taken you can still see the wrinkles and details of the original fabric clock.*

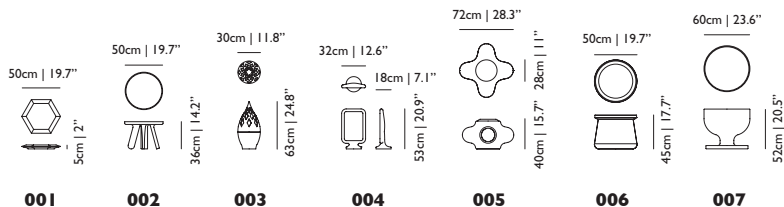

# ELEMENTS

## JAIME HAYON 2007

colour 002, 003, 004 & 007: black RAL 9005, white RAL 9016, warm grey RAL 7044 & ocean blue RAL 5020

material 002, 004 & 007: fibreglass (007 with glass top inlay) (004 with glass mirror)

material 003: aluminium powder coated

material 005 & 006: expanded polypropylene (EPP), upholstered with Kvadrat Divina Melange

colour 005 & 006: Kvadrat Divina Melange 120 (light grey), 180 (dark grey), 260 (light brown) & 681 (aubergine)

material 001 & 006: solid wood

colour tray 001 & 006: wenge, black & white

**in stock**

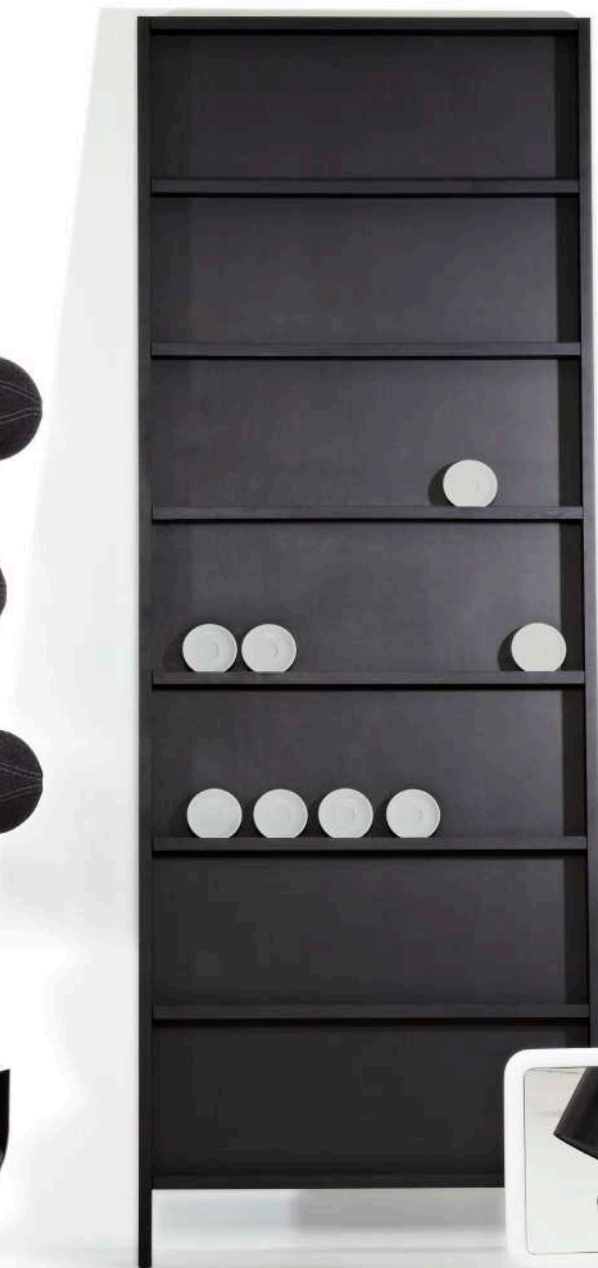



*Inspired originally by the form of a cactus and its modular shape, the various parts of the Elements collection resemble a functional sculpture: as beautiful as the cactus, but extremely versatile in their combinations and use.*

*The initial thought was to design a series of stackable stools in different materials. Then, luckily, a simple question was asked that turned everything around: "Why should they all be stools?" This led to a new concept where each piece of the stackable sculpture would have a different use: mirror, table, tray, etc. A variety of colours, materials and finishes were applied to each vertebra making the whole body of the sculpture richer and more flexible. From a cactus to a sculpture of different functional Elements.*



<https://www.lustrograd.com/vendors/moooi/>

**SMOKE CHANDELIER**  
**SMOKE DINING ARMCHAIR**  
**BIG BOLD**





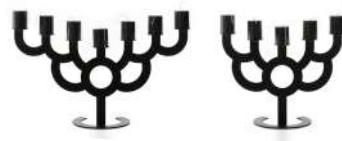

## LITTLE BOLD, MENORAH BOLD & BIG BOLD

**RODERICK VOS 2005**

material: powder coated steel, felt feet

colour: black

Bold candles to be ordered seperately

dim. little candle: 8 x 6 cm (h x ø) | 3.1" x 2.4", dim. big candle: 13 x 8 cm (h x ø) | 5.1" x 3.1"

**in stock**

*"The Bold series developed from my fascination with laser cutting technology.*

*With the use of a laser, you can cut a form or pattern in sheet metal with extreme accuracy. This technology allows you to handle the sheet very efficiently with very little wastage. The timeless appearance of the Bold series endows it with charisma, making it a worthy addition to the MOOOI collection!"*

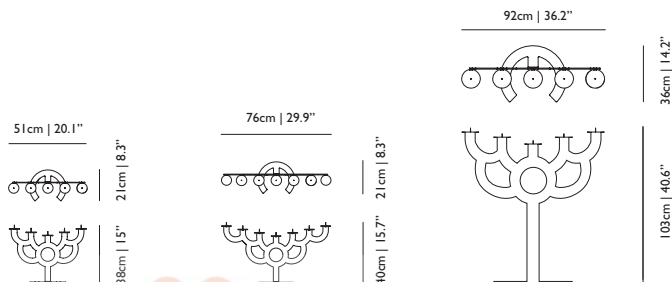

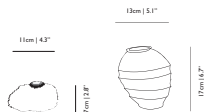

## **SPONGE VASE & MING VASE**

**MARCEL WANDERS 1997**

material: porcelain

colour: white

developed in a project with droog design & rosenthal

**in stock**



*The quality of porcelain is best reflected through its fine and delicate properties, a quality that is not celebrated when using a mould. Marcel Wanders has developed a technique to produce porcelain objects without the use of plaster moulds. A natural sponge is taken and dipped in a fluid porcelain clay slip. The clay impregnates the sponge. Once the sponge has dried, the sponge is fired within a Kiln. The sponge is burnt away and the perfect porcelain replica of the sponge remains. An intelligent manufacturing process that has the ability to show the intricate qualities of porcelain clay.*

*The same process is developed further on to make products by using pre-shaped artificial foam and make porcelain objects out of these, the foam bowl is a first example of the great possibilities with this technique.*

*The Ming Vase is a modern copy of a 3100 year-old handmade Chinese vase. It was found on the bottom of the sea in the wreck of an old Chinese junk. The vase was used as a jelly-jar for more than 300 years. The history of the product now makes a new turn. Marcel Wanders copied the shape and produced it in white porcelain. Like the Chinese ceramist we also leave our makers marks in the pot (like parting-lines, shrink), and thereby make a part of the vase's history visible.*

9cm | 3.5"

9cm | 3.5"

12.5cm | 4.9"



10cm | 3.9"



15cm | 5.9"



15cm | 5.9"

## EGG VASE & FOAM BOWL

**MARCEL WANDERS 1997**

material eggvase: unglazed porcelain outside, white glazed inside

material foam bowl: porcelain

colour: white

developed in a project with droog design & rosenthal.

**in stock**







**PAPER TABLE LAMP  
TWO TOPS SECRETARY  
BOUTIQUE SOPHY  
CONTAINER TABLE  
MONSTER CHAIR  
CONTAINER VASE  
ELEMENTS**

Naked photo by Erwin Olaf



**LUSTRO GRAD**  
ОПТОВЫЕ ПРОДАЖИ СВЕТИЛЬНИКОВ



**CHESS TABLE  
BLOW AWAY VASE**

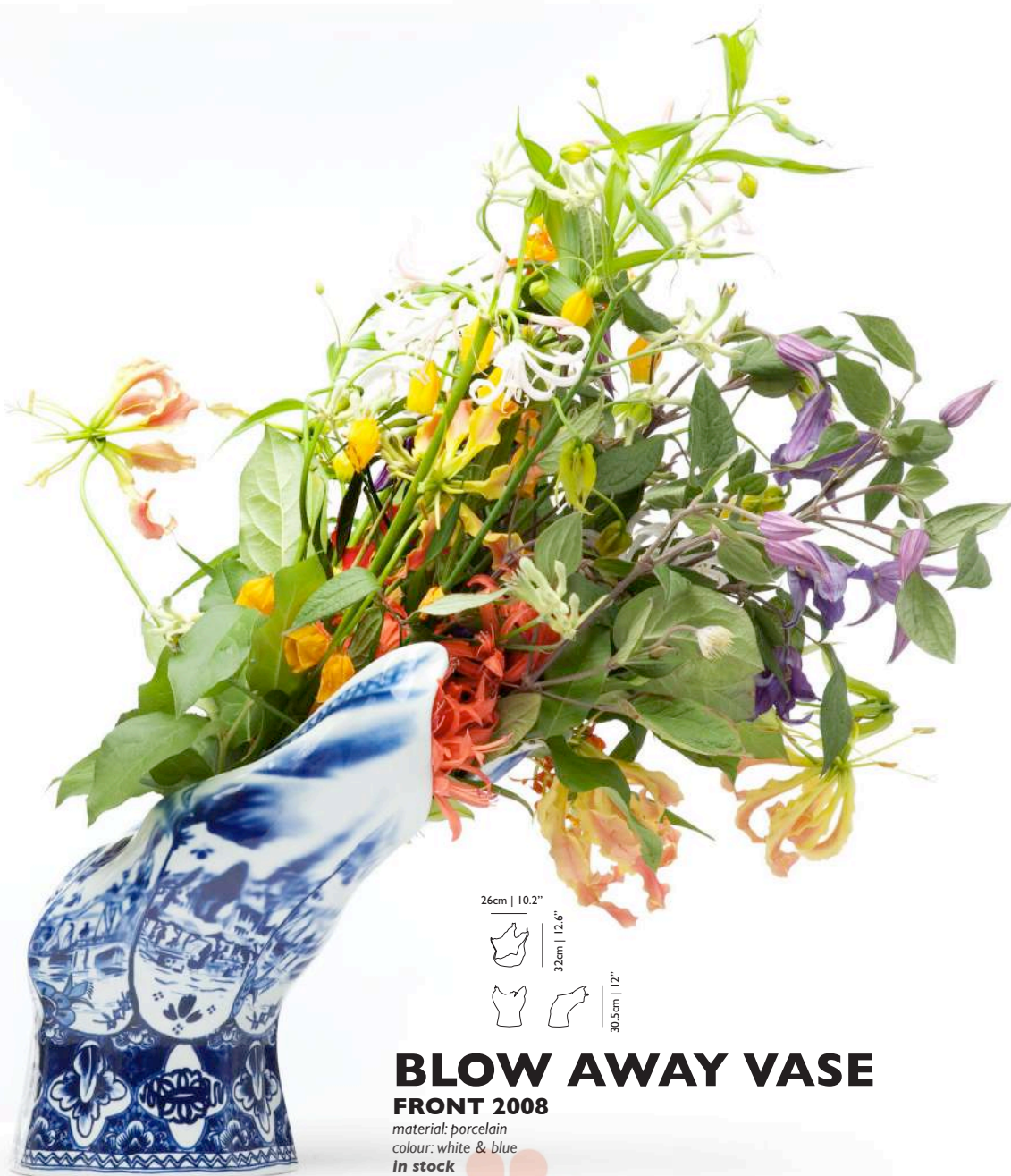

26cm | 10.2"



32cm | 12.6"



30.5cm | 12"

## **BLOW AWAY VASE**

**FRONT 2008**

material: porcelain  
colour: white & blue  
in stock



**FRAME MIRROR  
EMPEROR 100  
PIG TABLE  
BOUTIQUE XL TRIPLE SEATER MANGA  
CORKS  
OBLIQUE BIG  
TREE SUSPENDED**





75cm | 29.5" 20cm | 7.9"



## FRAME MIRROR

### MARCEL WANDERS 2007

*material: extruded and anodized aluminium baroque profile  
with black MDF back panel and glass mirror*

*colour: black*

*placement options: portrait & landscape*

**in stock**

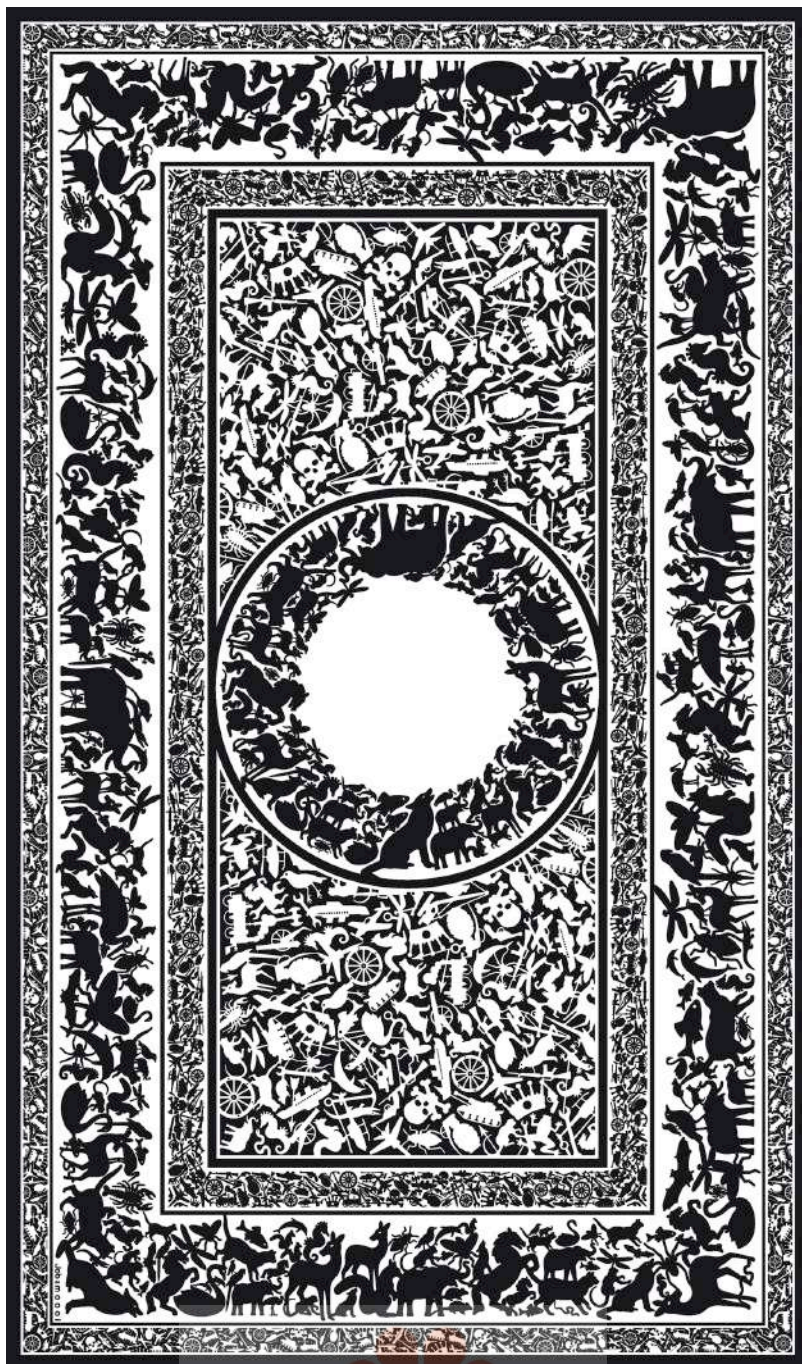

# THROW PANTHEON & JULY

**THROW PANTHEON BY STUDIO JOB 2003**

**THROW JULY BY MARCEL WANDERS 2005**

material: printed cotton

size: 276 x 169cm | 108.7" x 66.5"

**in stock**



*‘Throw’ is part of the Moooi Weer collection. It is the savior of old couches and allows you to create a new and warm visual quality in your house on a small budget. Throw is a “no-go” in the design industry, which makes it all the more exciting to introduce. If you don’t have an old couch, Throw can also be the perfect tablecloth for your next dinner with friends. Let’s inspire the shops, our clients and their friends with simple, fun, elegant and exciting products. Let’s surprise and have fun together doing it.*

**Let’s make the unexpected welcome.**





30cm | 11.8"

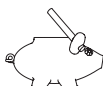

26cm | 10.2"

## **“THE KILLING OF THE PIGGY BANK” MARCEL WANDERS 2009**

*material: porcelain*

*colour: white, blue & gold*

***in stock***

*Delft Blue collection created by a collaboration between Marcel Wanders & Royal Delft.*

*The vase represents a digital age of currency and the approach to extinction for physical money.*

*The vase illustrates the precise moment the piggy bank is struck.*

**FRAME**  
**CONTAINER BOWL & FOOT**  
**CONTAINER VASE & FOOT**  
**SMOKE DINING CHAIR**  
**TWO TOPS SECRETARY**  
**RABBIT LAMP**  
**PAPER CHANDELIER L**  
**PAPER MIRROR**  
**PAPER CHANDELIER**



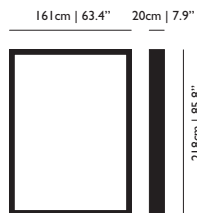
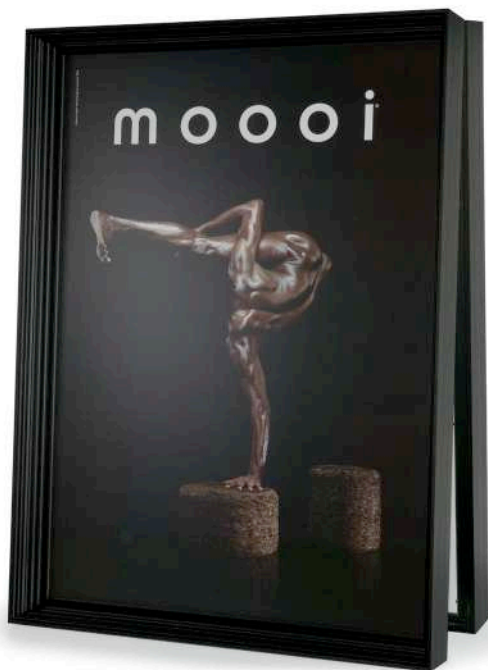

## FRAME

### MARCEL WANDERS 2005

*material: extruded and anodized aluminium*

*optional: connection set to put two frames back to back*

*colour: black*

*(excl. print)*

***in stock***

<https://www.lustrograd.com/vendors/moooi/>

**DELFT BLUE NO.6**

**DELFT BLUE NO.11**

**DELFT BLUE NO.10-2**









85cm | 33.5"

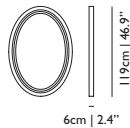

# PAPER MIRROR

## STUDIO JOB 2005

*material: wood and cardboard, finished with paper and polyurethane (PU) lacquer  
stainless steel fixing, glass mirror*

*colour: white*

*placement options: portrait & landscape*

**in stock**

**PAPER MIRROR**  
**PAPER BUFFET**  
**DELFT BLUE NO.2**  
**DELFT BLUE NO.8**  
**DELFT BLUE NO.4**  
**RAIMOND**





01

03



02



12

09

04



07



10

# CARPETS

## MARCEL WANDERS 2005

material: printed nylon threads  
various colours  
pole high carpet: 4.5mm | 0.2"  
total high carpet: 7.2mm | 0.3"  
square: 250 x 250cm | 98.4" x 98.4"  
rectangle: 200 x 300cm | 78.7" x 118.1"  
round: Ø240cm | 94.5"  
model 11: 100 x 800cm | 39.4" x 315"  
model 13 by Simone Pullens, 2008  
**in stock**

06

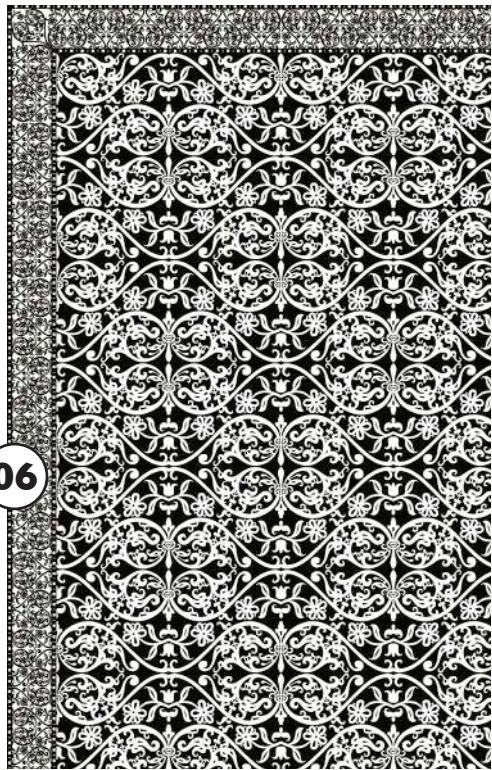

11

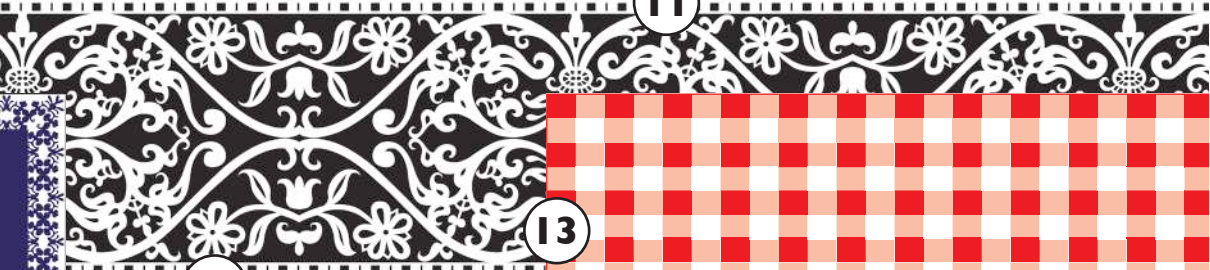

13

05

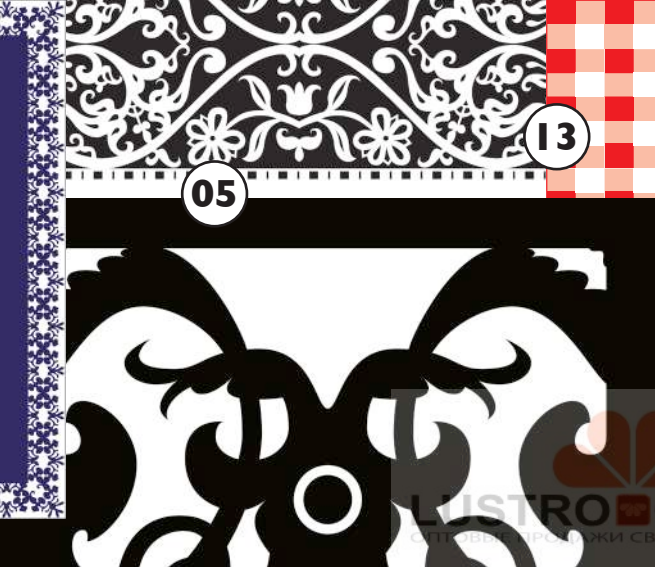



**PAPER SCREEN  
5 O'CLOCK CHAIR  
BOUTIQUE BLANKET NOVEMBER  
PAPER SIDE TABLE  
DELFT BLUE NO.8**

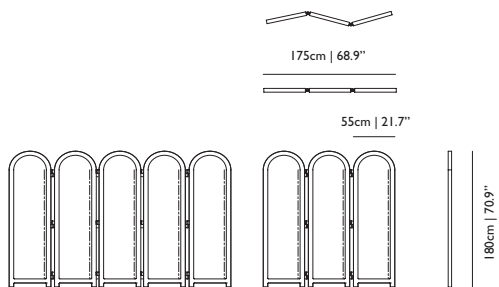

# PAPER SCREEN

## STUDIO JOB 2009

material: wooden base, paper & cardboard

colour: white

*a sturdy structure*

*additional paper panels may be purchased to extend the length of the Paper Screen wrapped within the perceptual softness of innocent paper.*

**in stock**





**ELEMENT 004**  
**DELFT BLUE NO.9-3**  
**DELFT BLUE NO.11**  
**DELFT BLUE NO.5**







**LUSTRO GRAD**  
ОПТОВЫЕ ПРОДАЖИ СВЕТИЛЬНИКОВ

5 O'CLOCK TABLE

AVL TABLE

BALLS

CHESS TABLE

CONTAINER TABLE

CONTAINER FOOT

CONTAINER TOP LPL

CONTAINER TOP HPL

CONTAINER TOP WOOD

CONTAINER TOP SKAI

CONTAINER TOP SKAI CUSTOMIZED

CROCHET TABLE

PAPER TABLE

PAPER SIDE TABLE

PARENT TABLE

PIG TABLE

TWO TOPS SECRETARY

TWO TOPS TABLE

# TABLES



**PAPER FLOORLAMP  
SMOKE DINING ARMCHAIR  
PAPER CHANDELIER XL  
CHESS TABLE  
SMOKE CHAIR**







60cm | 23.6"



167cm | 65.7"

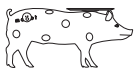

77cm | 30.3"

# PIG TABLE

**FRONT, 2006**

*material pig: fibreglass*

*material top: acrylonitrile butadiene styrene (ABS)*

*colour: black*

***in stock***



# BALLS

## BERTJAN POT 2005

material: oak veneer on honeycomb panel top, solid beech legs with powder coated steel fixings

colour: white lacquer with visible grain, black stained

thickness top: 31 mm

two achievable leg compositions to work with your chair arrangement

foldable table

**in stock**

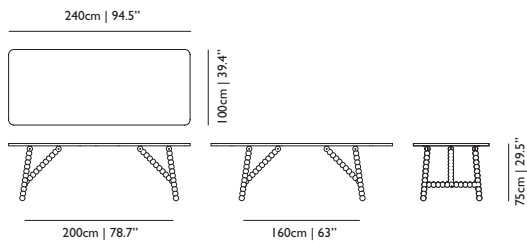





**PARENT CHAIR  
BALLS**

# CONTAINER TABLE

The container table concept is a fully versatile system of table tops and feet that has endless composition possibilities to suit any space. With combinations to match your home, office or public spaces the container table is the ideal solution for your every need. The design is extremely functional, yet faithful to its basic mission: to deliver extra beauty & value to its surroundings.

The table tops are available in a variety of materials, shapes and colors. The materials range from HPL to LPL, from lacquered wood to stained wood. The shapes range from round to square and rectangular.

The Container Table feet are available in five different dimensions, adding even more options to the numerous possibilities of the Container Table system. They are hollow and must be filled with sand or water to create extra stability.





# CONTAINER TABLE FOOT

## MARCEL WANDERS 2002

material: polyethylene (PE), stainless steel inserts and HPL mounting plate

the foot must be filled with sand or water to create extra stability, the Container Tops are available in 3 different

high quality materials to match your Container Foot,

HPL, LPL and wood Container Tops are shown on the next pages

the size of the top defines the size of the foot

colour: black, white, orange or red

**in stock**



# CONTAINER TABLE, HPL TOP

## MARCEL Wanders 2003

material: high pressure laminate (HPL), wood and paper pressed together under high pressure with thermosetting resins  
can be used outside

colour: white, black, wenge or light grey

thickness top: 12mm | 0.5"

the edges of HPL and LPL table tops are always black

**black & white ø70, 70x70, 80x80, ø90, ø120, ø140 & ø160 in stock**

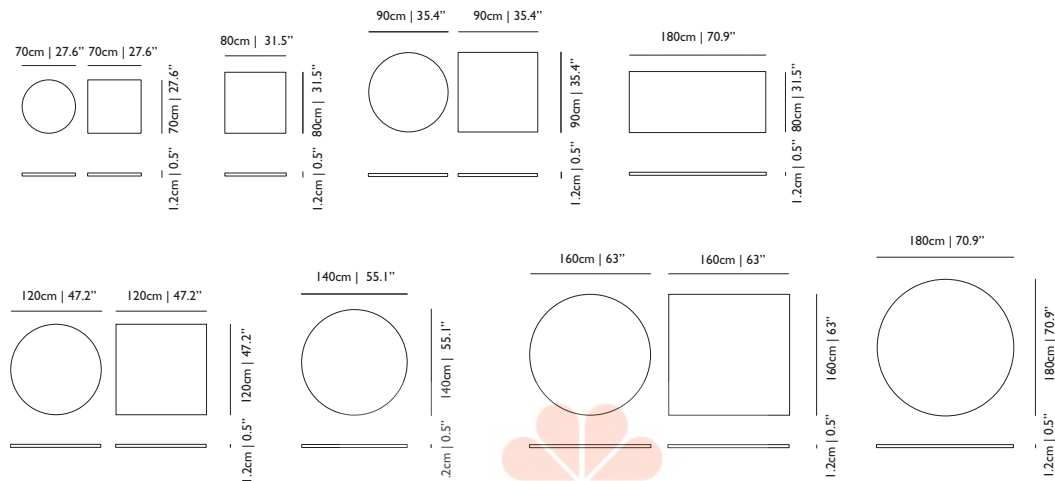

<https://www.lustrograd.com/vendors/moooi/>

**CONTAINER TABLE SKY**

**MONSTER CHAIR**

**MING VASE**

**DELFT BLUE NO.11**

**SOFT CLOCK**



**CONTAINER TABLE LPL**  
**CARBON CHAIR**  
**RANDOM LIGHT**  
**BOUTIQUE PILLOW DIARY**  
**SOFT CLOCK**  
**SPONGE VASE**

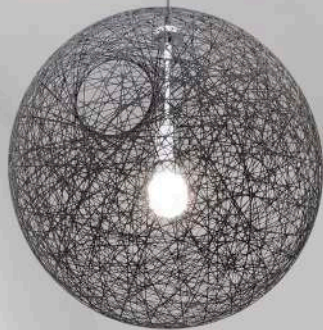

# CONTAINER TABLE, LPL TOP

## MARCEL WANDERS 2003

material: low pressure laminate (LPL), melamine top pressed on particleboard with ABS edges  
colour: white, black, wenge or light grey  
thickness top: 25mm | 1"  
the edges of HPL and LPL table tops are always black

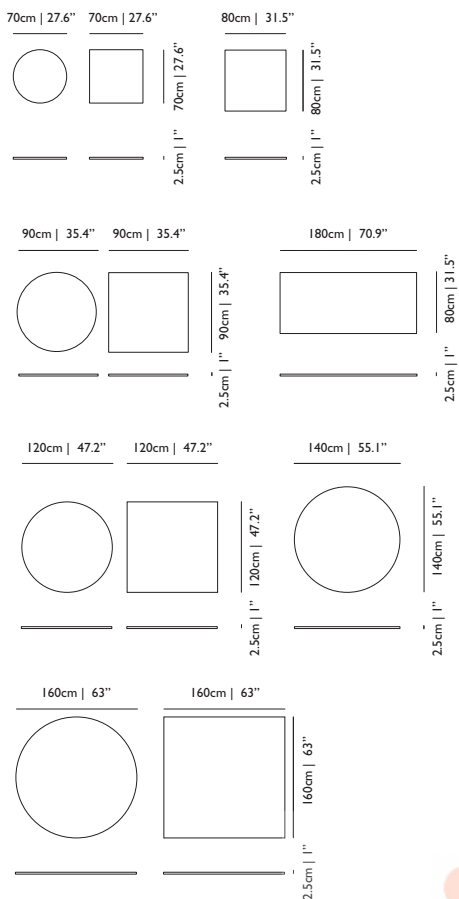







# CONTAINER TABLE, WOODEN TOP

## MARCEL WANDERS 2003









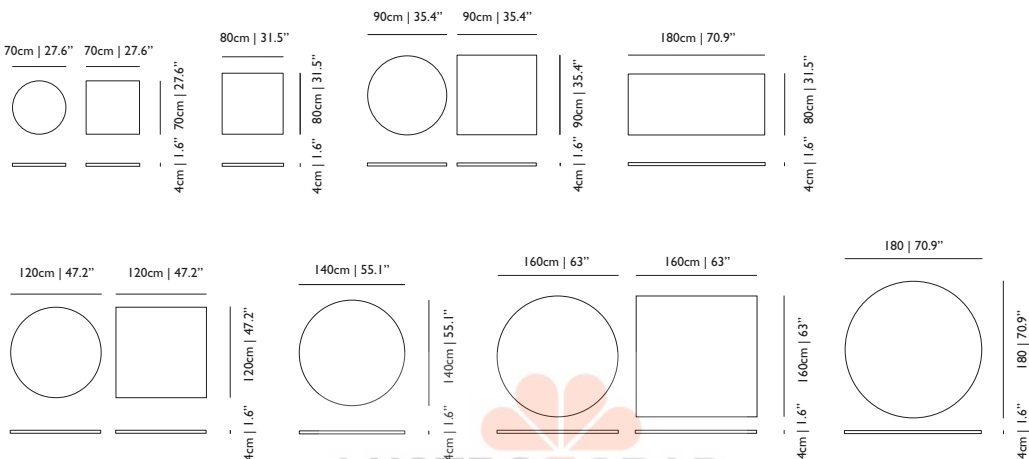

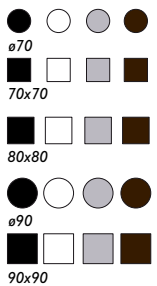
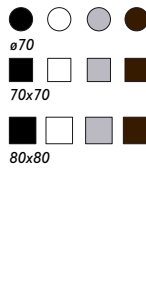

material: MDF with oak veneer, stained in 4 different colours  
and lacquered in 4 different RAL colours (white, black, orange or red)  
thickness top: 40mm | 1.6"

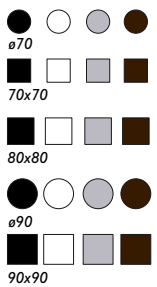
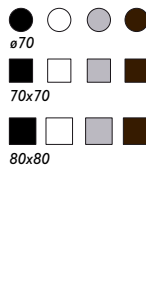
# STEEL COVER

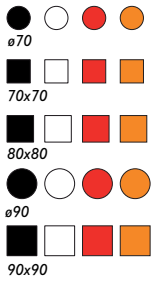
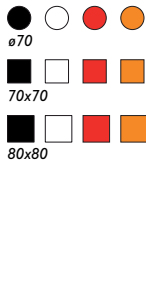
## MARCEL WANDERS 2003

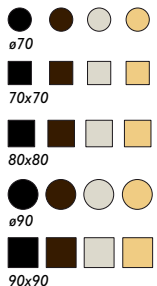
optional: powder coated steel cover to put over your container foot  
(7030, 7043, 7056)  
for indoor use  
colour: white RAL 9016, black RAL 9005,  
red RAL 3020, silver grey RAL 9006 & brown RAL 8016

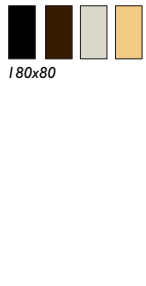
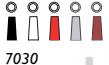

<p><b>Container Foot</b> black, white, red &amp; orange</p>			
<p><b>Container Top HPL</b> thickness 12mm   0.5" black, white, wenge &amp; light grey for outdoor use</p>			
<p><b>Container Top LPL</b> thickness 25mm   1" black, white, wenge &amp; light grey</p>			
<p><b>Container Top Wood Lacquered</b> thickness 40mm   1.6" black RAL9005, white RAL9016, red RAL3020, orange RAL2004</p>			
<p><b>Container Top Wood Stained</b> thickness 40mm   1.6" black, bloody brown, wenge, grey brown, white wash, natural lacquer</p>			
<p><b>Container Steel Cover</b> black, white, red, silver grey, brown</p>			

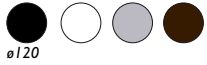

ø120

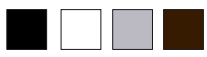

120x120

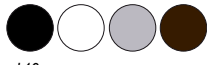

ø140



ø160

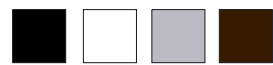

160x160

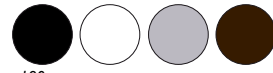

ø180



ø120

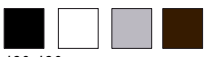

120x120

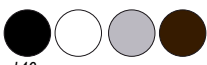

ø140



ø160



160x160

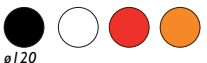

ø120



120x120



ø140



ø160



160x160



ø180



ø120



120x120



ø140



ø160



160x160



ø180

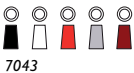



# CONTAINER TABLE SKAI TOP

**MARCEL WANDERS 2009**

*material: 25mm MDF top upholstered with Skai (Skai is a reg.tm)*

*colour: black, brown, white, green*

**on commission**

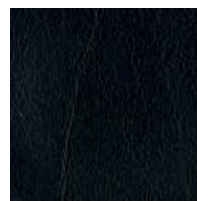
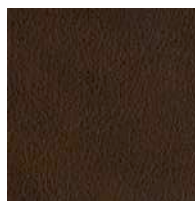
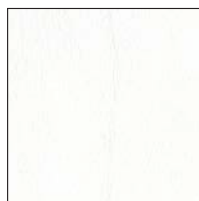
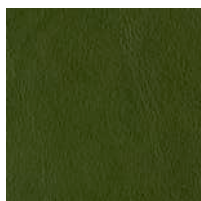



**SKAI COVER FOR THE CONTAINER SERIES**

The container series welcomes a new addition to the family, the Skai leather cover for the table tops. It's available in three different colors, with the possibility of customizing the print with a digital image. This new entry opens a new range of possibilities for the container series.

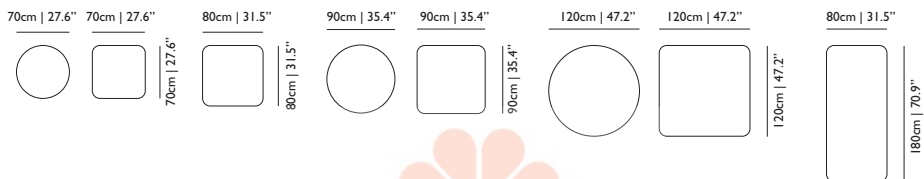

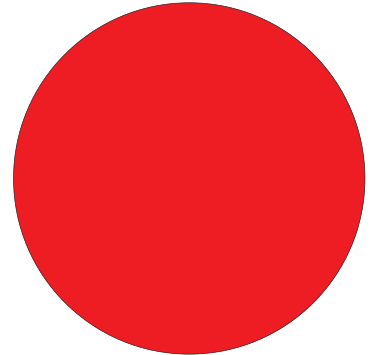
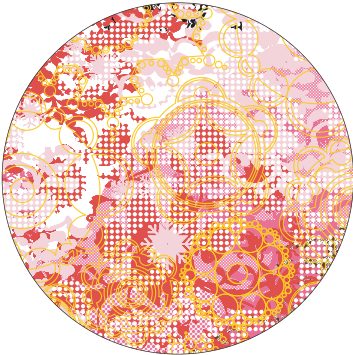
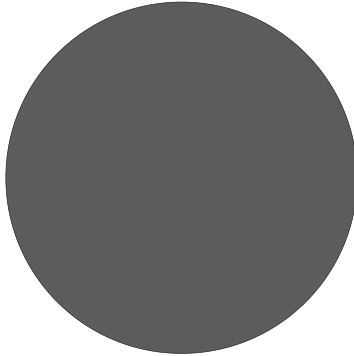
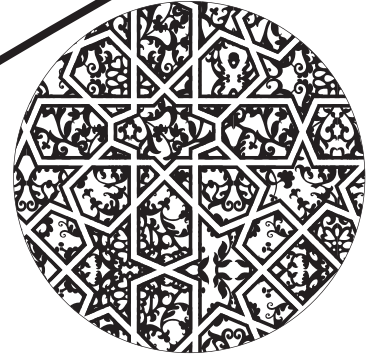
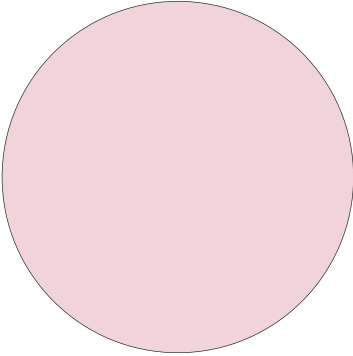
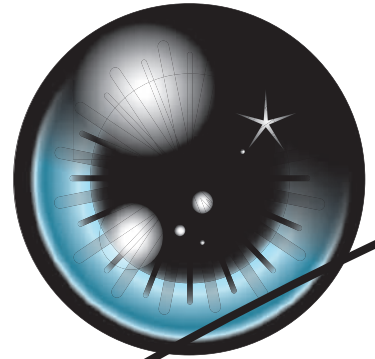
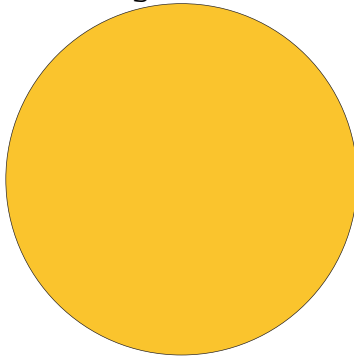
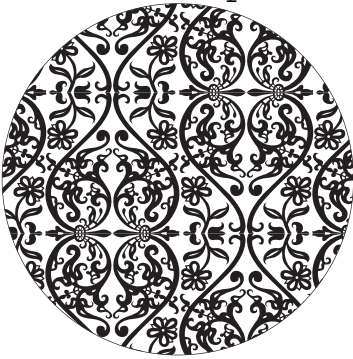



# CUSTOMIZED

## CONTAINER TABLE SKAI TOP CUSTOMIZED

*The Skai tops can be customized with any tailor-made digital image. This new entry opens a range of possibilities for the container series. Printing is always done on white SKAI.*

*available for all sizes Container Table SKAI tops from a minimum of 10 pieces  
(all with the same dimension and print)  
specifications available on request  
**on commission***

**CONTAINER TABLE WOOD**

**VICA**

**SET UP SHADE 5**

**SET UP SHADE 6**

**CONTAINER STOOL**

**DELFT BLUE NO.9-2**







30cm | 11.8"



44cm | 17.3"

# CONTAINER STOOL

**MARCEL WANDERS 2007**

*material: polyethylene (PE)*

*colour: black, white, red or orange*

*can be used outside*

**in stock**

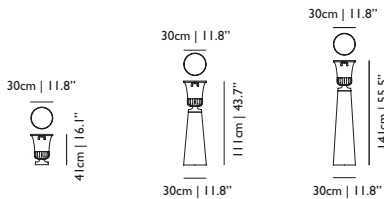

## CONTAINER VASE + FOOT

### MARCEL WANDERS 2007

material: polyethylene (PE)

colour: black or white

The special Container Vase Foot (7030, 10030) has an adaptor suitable for mounting the Container Vase can be used inside & outside for your flowers & champagne.

**in stock**





**CONTAINER VASE  
DELFT BLUE NO.9**



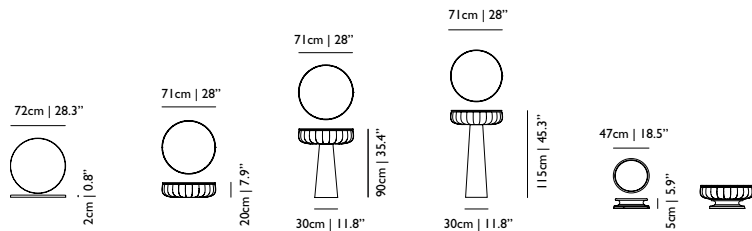

## CONTAINER BOWL + CONTAINER BOWL BASE

**MARCEL WANDERS 2007**

material: polyethylene (PE)

colour: black or white

optional Container Bowl Top

can be used outside

*Especially designed to create the perfect side-table with your container bowl.*

**in stock**

## CONTAINER BOWL TOP

**MARCEL WANDERS 2007**

material top: acrylonitrile butadiene styrene (ABS)

colour: black or white

*With the Container Top the Container Bowl is transformed into a delicate coffee table with storage possibilities!*

**in stock**







**NON RANDOM LIGHT Ø71  
AVL SHAKER CHAIR  
AVL TABLE 200**

- Elle Decoration UK December 2010: "Uber-cool Dutch brand Moooi has opened a sexy new London showroom – its first in the UK."



# AVL TABLE

## JOEP VAN LIESHOUT 1999

material: solid oak frame, oak veneer top

covering lacquers with wood structure

colour: lacquered in white, black or red

**in stock**

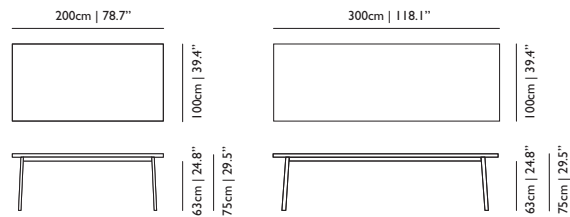





# CHESS TABLE

## FRONT 2008

*material: various woods, internal steel frame, high gloss lacquer*

*The pattern on the side table can be used for playing games. A table for pastimes, rivalry and skill.*

**in stock**

40 cm | 15.7"



5 cm | 2"

60 cm | 23.6"



## **CROCHET TABLE 3030 & 3060 MARCEL WANDERS 2001**

*material: handmade cotton crochet, drained in epoxy resin*

*colour: white*

**in stock**

*Defying all fabric capabilities, the lace Crochet Table is the ultimate accessory for any interior.*

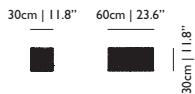

**BOUTIQUE SINGLE SEATER CHAMELEON HALLINGDAL  
CROCHET TABLE  
DELFT BLUE NO.2**



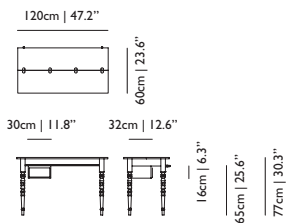

## TWO TOPS SECRETARY MARCEL WANDERS 2004

*material: solid oak frame, MDF with oak veneer top,*

*stained in 4 different colours or lacquered in 4 different colours (white, black, orange & red)*

*optional: white storage box in powder coated steel to put underneath your secretary*

***in stock: white lacquered & black stained***



**TWO TOPS SECRETARY  
MING VASE  
KAIPO  
LIGHT SHADE SHADE FLOORLAMP**



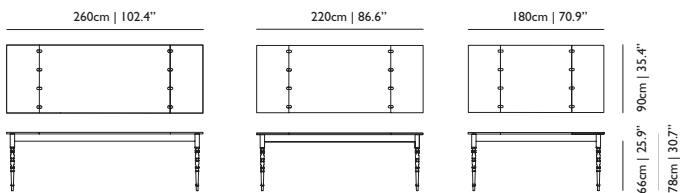

## TWO TOPS TABLE

### MARCEL WANDERS 2004

material: solid oak frame, MDF with oak veneer top,

stained in 4 different colours or lacquered in 4 different colours (white, black, orange & red)

**in stock: white lacquered & black stained**



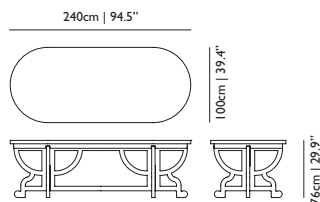

## PAPER TABLE

### STUDIO JOB 2005

material: wood and cardboard, finished with paper and

polyurethane (PU) lacquer

colour: white

available space between floor and table is 65.5cm

A sturdy structure wrapped in the visual softness and innocence of paper.

**in stock**







**- Grove Northwest UK October 2010**

*'Moooi is more than just fairytale fantasy: every piece is playful and functional, durable and luxurious. The people responsible for this incredible space and the striking furniture, lighting and accessories within it are Casper Vissers and Marcel Wanders, founders of international design brand Moooi. With Moooi's innately stylish designs it's hard to see how anyone will resist.'*



40cm | 15.7"



60cm | 23.6"

# PAPER SIDE TABLE

## STUDIO JOB 2008

*material: wood and cardboard, finished with paper and polyurethane (PU) lacquer*

*colour: white*

*A sturdy structure wrapped within the perceptual softness of innocent paper.*

**in stock**



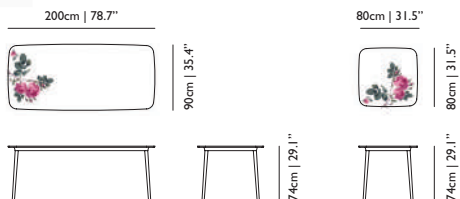

## 5 O'CLOCK TABLE

**NIKA ZUPANC 2009**

material: solid beech frame, MDF top  
upholstery: upholstered with fire retardant synthetic leather with print, abrasion test of >35.000 rubs Martindale, easy to maintain, soft touch, long service life, flame retardant, easy to clean, suitable for project use (used in hospitals), stain resistant.  
available height between floor and frame 68cm  
**in stock**



by Nika Zupanc

## Secrets

Tito's tea house, Belvedere Pavilion, lake Bled, Wednesday, September 2009. Just after 5 o'clock.

*Presiding over an alpine lake it offers the magnificent view and an interior that is so much more than just a charming place to drink a cup of tea. Its retro interior has remained unchanged, frozen in time all the way from the 50es. This place is able to take you back in the fragile times of forgotten values, forbidden loves and secret talks. From up here, you can almost see the battles of life's that silently passed by.*

*And it was in this place that I first thought I just had to design a chair.  
One that would radiate the beauty and the pain of irreversibility of time.*

*'In a world of design which is dominated by rationalism, minimalism and technology, it is a pleasure and a necessity to find a scarce and lonely soul who puts forward her power and sensitivity to create pieces with a smart esthetic and feminine language. Let's hope she will lead a way for the long awaited emancipation of femininity in design'*

**Marcel Wanders** (quote on Nika Zupanc)





**LUSTRO GRAD**  
ОПТОВЫЕ ПРОДАЖИ СВЕТИЛЬНИКОВ



# STORAGE

CITY  
OBLIQUE BIG  
OBLIQUE SMALL  
PAPER BUFFET  
PAPER CABINET  
PAPER CUPBOARD  
PAPER WARDROBE



**LUSTRO GRAD**  
ОПТОВЫЕ ПРОДАЖИ СВЕТИЛЬНИКОВ

**OBLIQUE BIG  
CARBON CHAIR  
TREE FLOORLAMP XL**

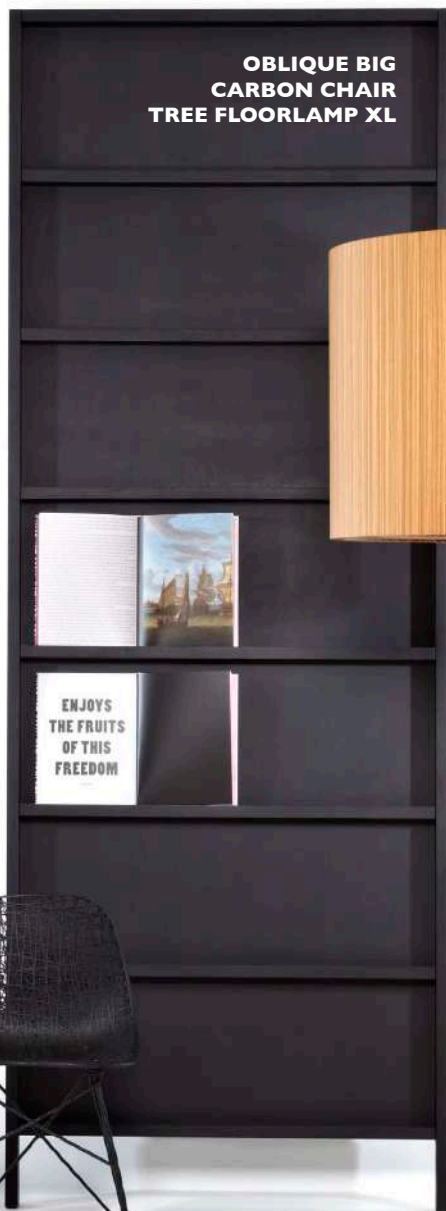

105cm | 41.3" | 6cm | 2.4"

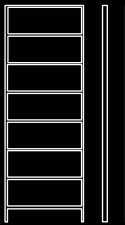

286cm | 112.6"

# OBLIQUE BIG

## MARCEL WANDERS 2002

material: solid oak stained and lacquered in  
4 different colours (with visible wood structure)  
or lacquered beech in 4 different colours (white, black, orange or red)  
**in stock: white lacquered & black stained**



**LUSTRO GRAD**  
ОПТОВЫЕ ПРОДАЖИ СВЕТИЛЬНИКОВ



105cm | 41.3" 6cm | 2.4"

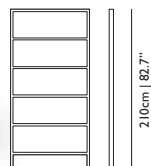

# OBLIQUE SMALL

**MARCEL WANDERS 2002**

*material: solid oak stained and lacquered in 4 different colours (with visible wood structure)  
or lacquered beech in 4 different colours (white, black, orange or red)*

***in stock: white lacquered & black stained***



*Oblique is designed to lean against a supporting wall.*



**CITY**  
**SMOKER MAN**  
**CROCHET TABLE**  
**CHESS TABLE**  
**DOUBLE SHADE**  
Super Hero by Erwin Olaf  
Naked photo by Erwin Olaf



# CITY

## MARCEL WANDERS 2002

material: powder coated steel

colour: white

the 72 x 72 cm cupboard with doors is delivered with an audio outlet

**in stock**

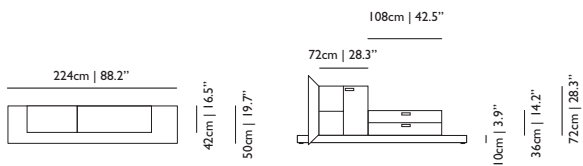

# PAPER COLLECTION

## STUDIO JOB

*Did the idea of paper furniture ever strike your mind?*

*Paper, cardboard and papier-mâché are familiar to all of us. They bring back long-lost memories of kindergarten and our first experiences of making things with our own hands, coloring, cutting, shaping and wrapping like busy bees.*

*We can generate almost anything from a white sheet of paper: from basic shapes and everyday objects to dramatic love letters and life-changing novels. It is a material with infinite potential, waiting for the dreamer to give it a shape.*

*Inspired by classic icons but manufactured like modern day furniture, this cardboard flat pack furniture collection is an ode to a classical style and to a material that makes everything possible. Even hanging your clothes or storing your shoes in a solid piece of furniture made of paper!*



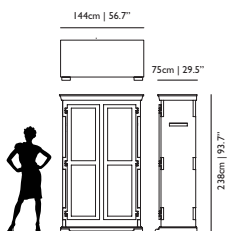
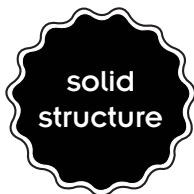

# PAPER WARDROBE

## STUDIO JOB 2005

*material: honeycomb panels paper and cardboard*

*colour: white*

*maximum shelf load 60KG evenly distributed*

**in stock**



**PAPER CABINET  
BRAVE NEW WORLD**

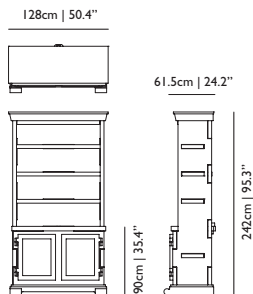

# PAPER CABINET

## STUDIO JOB 2005

*material: honeycomb panels paper and cardboard*

*colour: white*

*maximum shelf load 60KG evenly distributed*

**in stock**

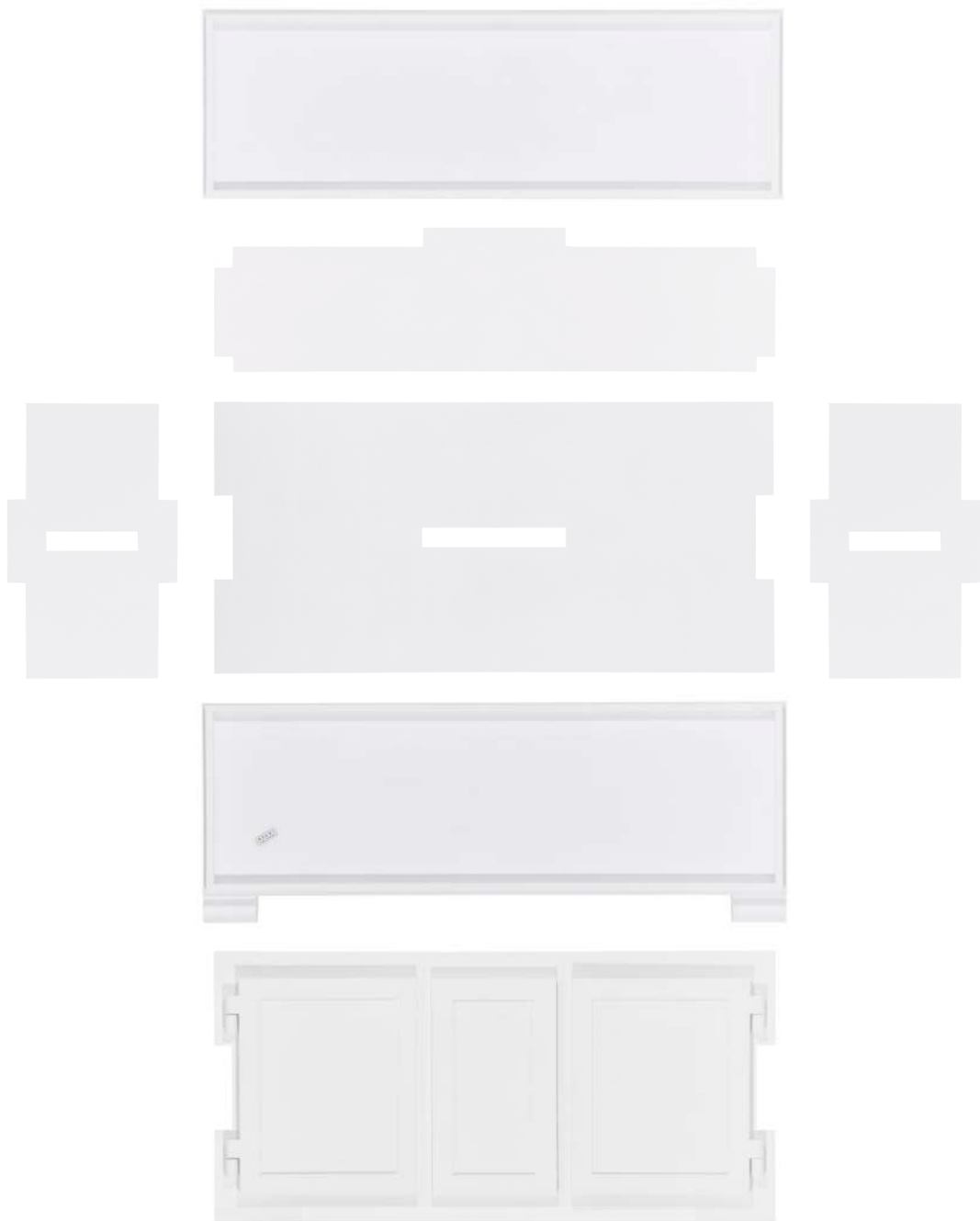

**PAPER STORAGE COMES FLAT PACKED.  
EASY TO BUILD AND INSTALL!**

solid  
structure

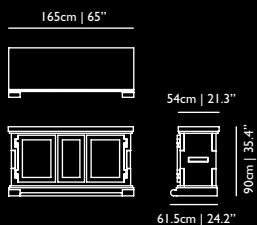
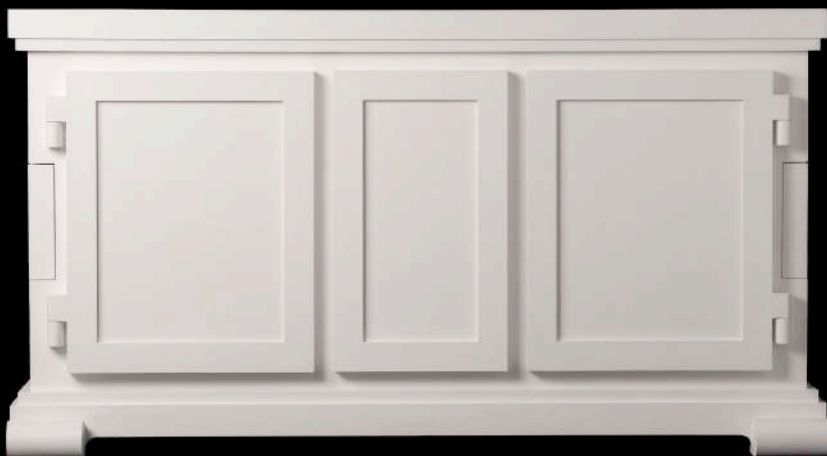

## PAPER BUFFET

### STUDIO JOB 2005

material: honeycomb panels paper and cardboard

colour: white

maximum shelf load 60KG evenly distributed

**in stock**



SALONE DEL MOBILE 2010

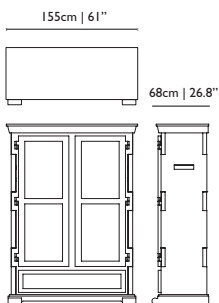

# PAPER CUPBOARD

## STUDIO JOB 2005

*material: honeycomb panels paper and cardboard*

*colour: white*

*maximum shelf load 60KG evenly distributed*

**in stock**





5 O'CLOCK CHAIR  
AVL SHAKER CHAIR  
AVL BARSTOOL  
BARBARELLA  
BOTTONI  
BOTTONI SLIM  
BOTTONI SHELF  
CARBON CHAIR  
CLIP CHAIR  
CONTAINER STOOL  
CORKS  
DICKIE  
MANNEQUIN  
MANNEQUIN LOUNGE  
MONSTERCHAIR  
PARENT CHAIR  
SMOKE DINING  
SMOKE DINING ARMCHAIR  
SMOKE CHAIR  
VICA  
V.I.P. CHAIR

# SEATERS

**RAIMOND  
MONSTER ARMCHAIR  
CHESS TABLE**

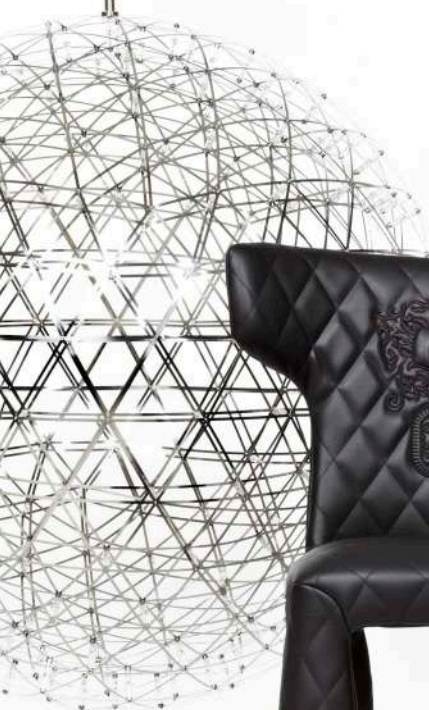



## **MONSTER ARMCHAIR MONSTER CHAIR**

**MARCEL WANDERS 2010**

*material: steel frame*

*upholstery: fire retardant synthetic leather upholstery, abrasion test of  
>180.000 rubs Martindale*

*colour: black*

*Monster chairs can be ordered with or without monster face and with or  
without armrests. The monster embroidery is identical in both versions.*

**in stock**

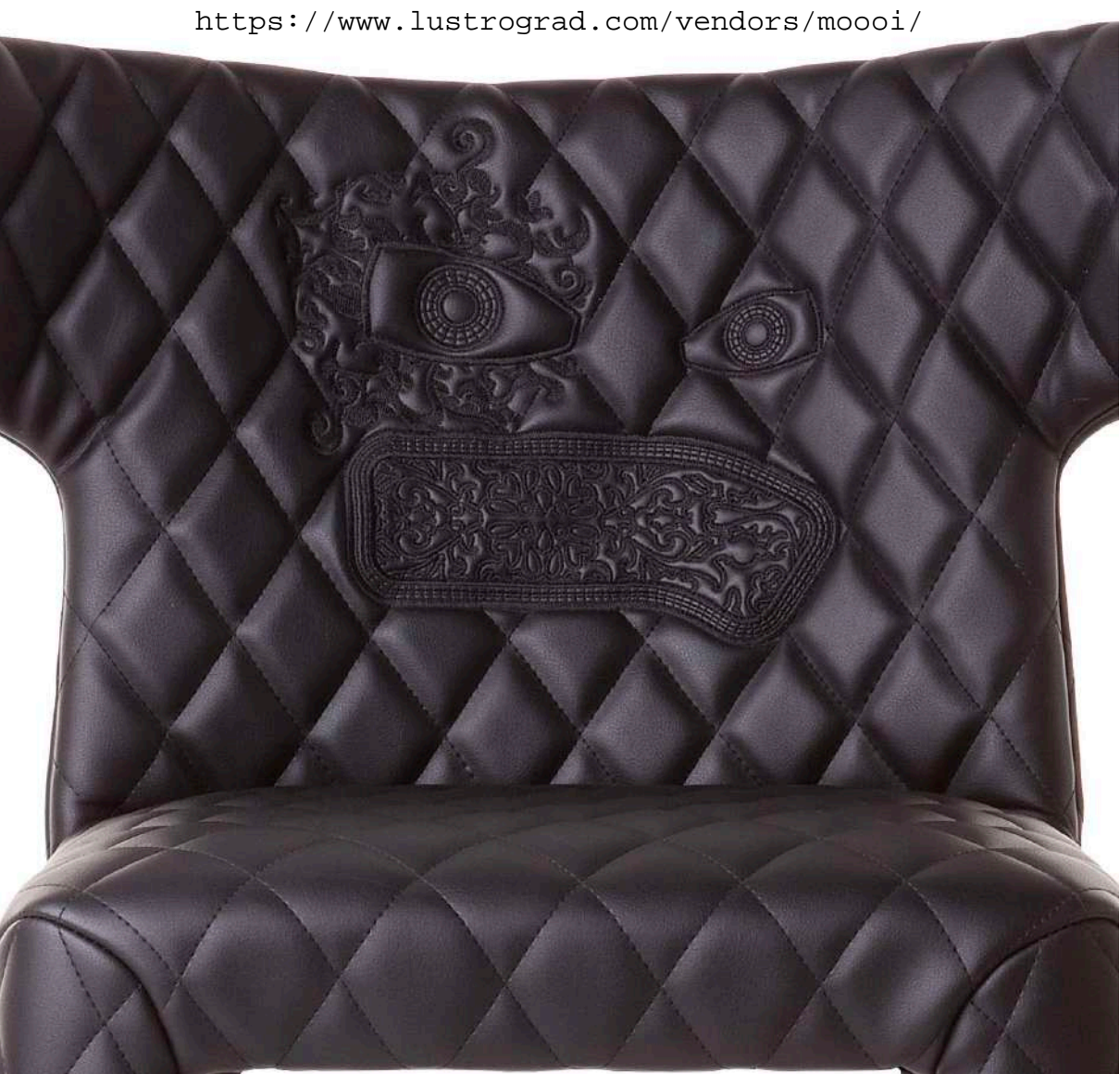

**Monster Armchair with embroidery**

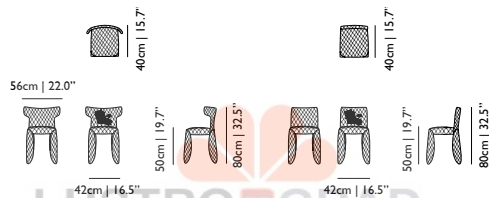



**BALLS  
DELFT BLUE NO.6  
DANDELION  
MONSTER CHAIR**



# 5 O'CLOCK CHAIR

**NIKA ZUPANC 2010**

*material: solid beech frame, plywood shells*

*upholstery: fire retardant foam, fire retardant synthetic leather with print, abrasion test of >35.000 rubs Martindale*

**in stock**

*The rose pattern is randomly printed on seat and backrest creating 24 different chairs.*



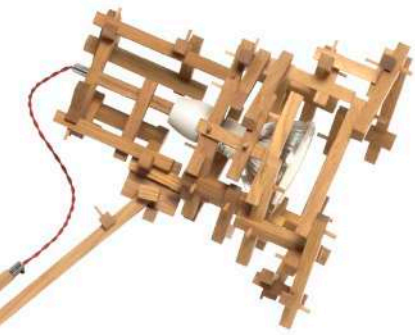

**BRAVE NEW WORLD  
5 O'CLOCK CHAIR  
LOLITA FLOORLAMP  
SOFT CLOCK**







**5 O'CLOCK TABLE**

**5 O'CLOCK CHAIR**

**PAPER SCREEN**

**BOUTIQUE BLANKET NOVEMBER**

**PAPER SIDE TABLE**

**LOLITA TABLELAMP**



*From the very beginning fire has inspired people with its warm glow and almost living motion, generating fascination and fear, comfort and warmth, passion and pain. It has been associated with emotions, personalities, love and has become part of the language of literature and of the vocabulary & gestures of our daily life.*

*Maarten Baas interpreted his fascination for the element fire with a groundbreaking approach. With the innovative idea of creating furniture furnished with fire. Capturing the burning flames into the solidity of wood. More practically, in the production process wooden pieces of furniture are set to fire and burned. When they become completely black the fire is extinguished and the piece of burned furniture are impregnated with resin to capture the beauty of burned wood.*

*Just like the Phoenix, the Smoke Chairs are reborn from their ashes, gaining new vitality and beauty in a very unusual way.*



# SMOKE DINING ARMCHAIR

## MAARTEN BAAS 2010

*material: burnt wood, finished with epoxy resin, fire retardant (FR) foam, leather upholstery, each chair is unique*

*colour: black*

**in stock**

60 cm | 23.6"



63 cm | 24.8"

71 cm | 28"



49 cm | 19.5"



106 cm | 41.7"



75cm | 29.5"



80cm | 31.5"



40cm | 15.7"



104cm | 40.9"

# SMOKE CHAIR

**MAARTEN BAAS 2002**

*material: burnt wood, finished with epoxy resin,*

*fire retardant (FR) foam, leather upholstery*

*each chair is unique*

*colour: black*

*Furniture finished with fire.*

*The beauty and character of burnt wood is now captured in a long lasting material,  
creating the strange sensation of burnt furniture.*

**in stock**



**SMOKE CHAIR  
PAPER CHANDELIER XXL  
CHESS TABLE**



## SMOKE DINING CHAIR

**MAARTEN BAAS 2004**

material: burnt wood, finished with epoxy resin,  
fire retardant (FR) foam, leather upholstery  
each chair is unique  
colour: black  
**in stock**

**LUSTROGRAD**  
ОПТОВЫЕ ПРОДАЖИ СВЕТИЛЬНИКОВ

48cm | 18.9"



57cm | 22.4"



106cm | 41.7"



51cm | 20.1"





**RAIMOND**  
**V.I.P. CHAIR**  
**AVL SHAKER CHAIR**  
**DELFT BLUE NO.5**

Naked photo by Erwin Olaf





## V.I.P. CHAIR

### MARCEL WANDERS 2000

material: fire retardant foam covered steel frame, hard nylon wheels  
fabric: kvadrat divina or divina melange  
V.I.P. on wheels!

**Divina Melange 180 & 120 in stock** other colours on commission

62cm | 24.4"



62cm | 24.4"



46cm | 18.1"

66cm | 26"



81cm | 31.9"





42cm | 16.5"



50cm | 19.7"



49cm | 19.3"



76cm | 29.9"

## MANNEQUIN

### MARCEL WANDERS 2006

material frame: powder coated steel with nylon feet  
from left to right

Feminine cover: polyester, cotton and viscose fabric

Black Jester cover: polyester and cotton fabric

Damast cover: polyester and cotton fabric

removable FR foam seat

the cover can be removed for cleaning, dry clean only  
**in stock**



57cm | 22.4"



61cm | 24"



38cm | 15"



66cm | 26"

## MANNEQUIN LOUNGE MARCEL WANDERS 2007

material frame: powder coated steel with nylon feet and silicon mat  
from left to right

Black Jester cover: polyester and cotton fabric

Feminine cover: polyester, cotton and viscose fabric

Damast cover: polyester and cotton fabric  
removable FR foam seat

the cover can be removed for cleaning, dry clean only

**in stock**





can be  
used  
outside!



**LUSTROGRAD**  
ОПТОВЫЕ ПРОДАЖИ СВЕТИЛЬНИКОВ

**CARBON CHAIR**  
**TWO TOPS SECRETARY**  
**FRINGE 5**  
**LITTLE BOLD**

47cm | 18.5"



49cm | 19.3"



46cm | 18.1"

79cm | 31.1"

# CARBON CHAIR

**BERTJAN POT & MARCEL WANDERS 2004**

*material: carbon fibre drained in epoxy resin*

*colour: black*

**in stock**









48cm | 18.9"



46cm | 18.1"



46cm | 18.1"



71cm | 28"

# AVL SHAKER CHAIR

**JOEP VAN LIESHOUT 1999**

*material: solid oak frame lacquered in 3 different RAL colours  
(white, black & red)*

**in stock**





40cm | 15.7"



40cm | 15.7"



81cm | 31.9"



99cm | 39"

# AVL BAR STOOL

JOEP VAN LIESHOUT 2003

material: solid oak frame lacquered in 3 different RAL colours

(white, black & red)

**in stock**

**PIG TABLE**  
**VICA**  
**RANDOM LIGHT MEDIUM**  
**PAPER MIRROR**  
**DELFT BLUE NO.6**  
**CORK LOW**  
**PAPER CHANDELIER XXL**







54cm | 21.26"



46cm | 18.1" 58cm | 22.83"



79cm | 31.1"

# VICA

## BERTJAN POT 2007

material: steel frame covered with polyester sleeve, upholstered with Kvadrat Field fabric on fire retardant foam

colour: red (Kvadrat Field 662) black (Kvadrat Field 192) or Grey (Kvadrat Field 132)

stackable chair  
in stock



# BARBARELLA

## ROSS LOVEGROVE 2005

material: multiple density foam over plywood frame, stainless steel feet. FR foam upon request  
upholstery: sheep skin

single seater/double seater/triple seater/footstool  
**on commission**

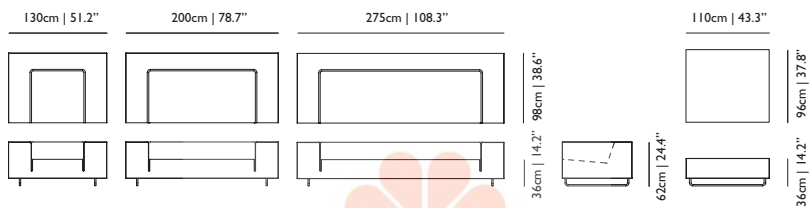





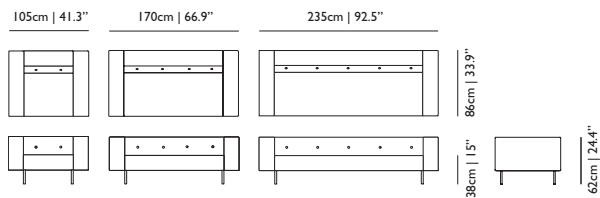

# BOTTONI

## MARCEL WANDERS 2002

material: multiple density foam on plywood frame, stainless steel feet. FR foam upon request  
variety of upholstery; kvadrat divina, tonica, hallingdal or your own

single seater/double seater/triple seater

**on commission**

<https://www.lustrograd.com/vendors/moooi/>

**BOTTONI TRIPLE SEATER  
RANDOM LIGHT  
CROCHET TABLE  
CARPET MODEL 06  
BOUTIQUE BLANKET NOVEMBER**

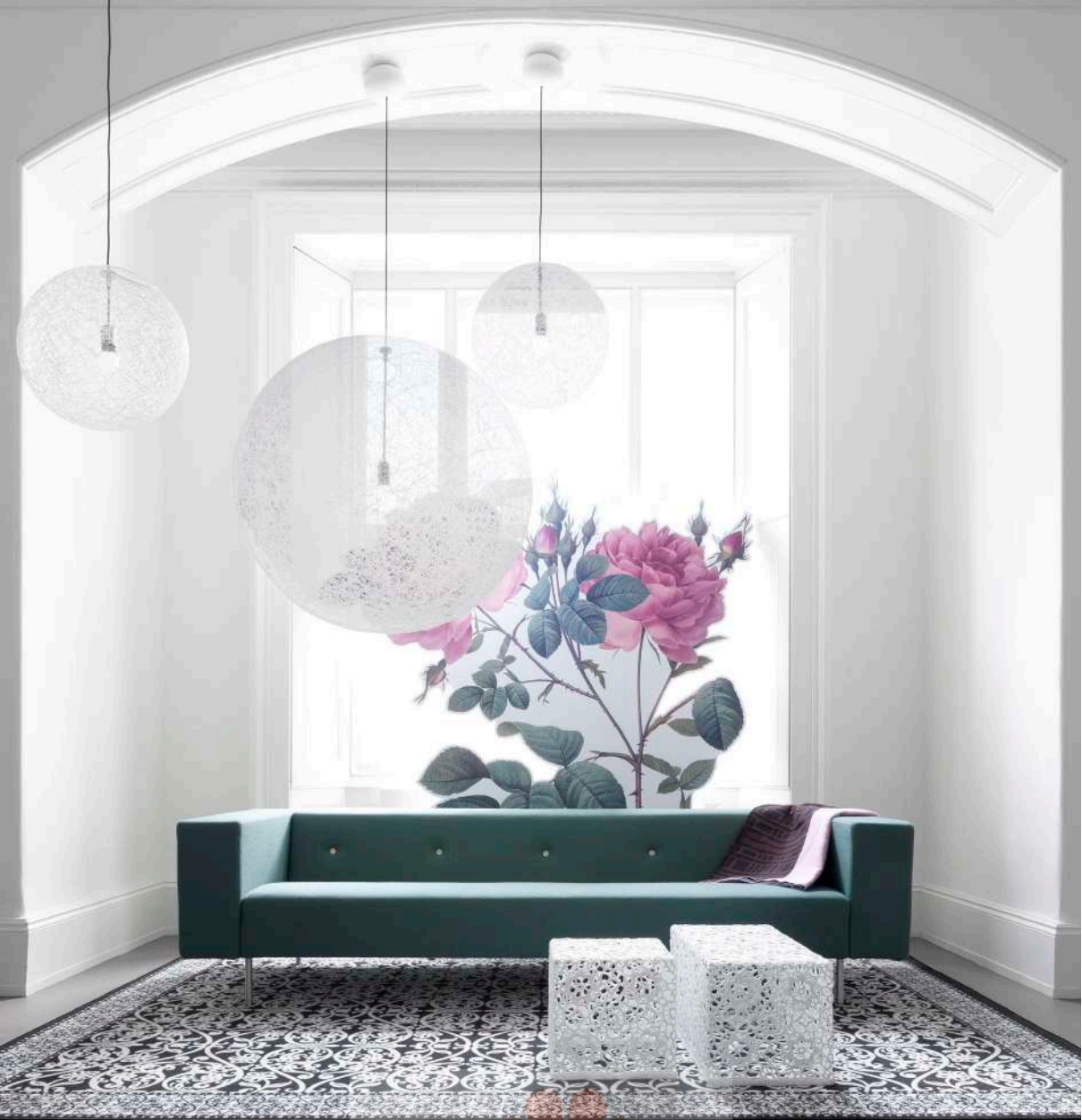

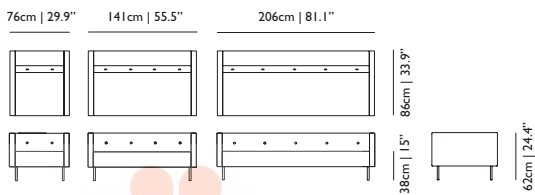



## **BOTTONI SLIM**

**MARCEL WANDERS 2003**

*material: multiple density foam on plywood frame, stainless steel feet. FR foam upon request  
variety of upholstery; kvadrat divina, tonica, hallingdal or your own*

*single seater/double seater/triple seater*

**on commission**



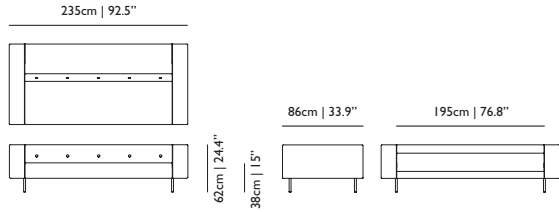

## **BOTTONI SHELF**

### **MARCEL WANDERS 2004**

*material: multiple density foam on plywood frame, stainless steel feet. FR foam upon request  
variety of upholstery; kvadrat divina, tonica, hallingdal or your own*

*only available as triple seater*

**on commission**







# CLIP CHAIR

**BLASIUS OSKO & OLIVER DEICHMAN 2006**

*material: solid beech with stainless steel fixings*

*stained in wenge, lacquered in white or black*

*foldable*

**in stock**

85cm | 33.5"



65cm | 25.6"



30cm | 11.8"



73.5cm | 28.9"

**CLUSTER LAMP  
PARENT CHAIR & TABLE**



**EMPEROR SUSPENDED 60  
PARENT CHAIR & TABLE**



## PARENT TABLE & PARENT CHAIR

### MARCEL WANDERS 2008

material: EPP - expanded polypropylene

colour: black

**in stock**

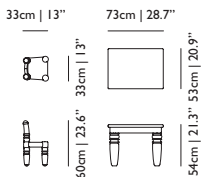

Children's furniture for the parents! Who says children's furniture has to be mismatched with your own style. Marcel Wanders and Moooi have brought this great addition to your home to the collection. The Parent Table is soft, light and extremely robust.

**Perfect to play with and stylish to own.**





**BOUTIQUE XL TRIPLE SEATER MANGA**  
**CARPET MODEL 03**  
**CORKS**  
**SMOKE CHAIR**



32cm | 12.6"    45cm | 17.7"



34cm | 13.4"

25cm | 9.8"



# CORKS HIGH & LOW

**JASPER MORRISON 2002**

material: 100% solid cork

**in stock**

105cm | 41.3"



110cm | 43.3"

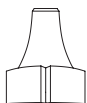

120cm | 47.2"



45cm | 17.7"



# DICKIE

## ANTHONY KLEINEPIER 2004

material: expanded polystyrene fill, in polypropylene and nylon laminate bag

colour: dark grey

**in stock**





# BOUNTIFUL

*Jester*

*Medallion*

*Manga*

*Deer*

*Diary*

*Silver*

*Travis*

*Kimono*

*Daddy*

*Lace*

*Coco*

*Chameleon Divina*

*Chameleon Hallingdal*

*New York*

*Easy Rider*

*Sophy*

*Leather*

# MOOOI BOUTIQUE

*Moooi Boutique sofas are exclusive and unique designs that bring a touch of class and make an immediate statement in any interior.*

*They are composed by a naked sofa (Boutique or Boutique XL), 17 different covers and 4 different types of legs. Together, it makes for a huge range of possible variations. The creative, detailed and fashionable textile covers are developed especially for Moooi Boutique. Each cover transmits a particular feeling and character although they all represent great style embodied in a sofa.*

*In 2008 Boutique XL was introduced as extension of the Boutique concept. Boutique XL is characterized by bigger armrests, bigger cushions and pillows, a deeper seat and an XL body to give it a voluptuous look. Your Boutique XL sofa is produced to order.*

*The standard units are a single seater, double seater, triple seater and footstool. All available in a timeless, universal design. Their contours, dimensions and sheer comfort make them highly sitter-friendly and they are upholstered in the carefully designed Moooi Underwear fabric. Even when the covers are removed for cleaning, the sofa still looks fresh and stylish.*

*From wool to cotton and linen to leather, the fabrics are just as diverse as the meaning behind the designs. In fact Boutique covers draw their inspiration from the most diverse sources: from icons of the fashion world such as Coco Chanel to geographical icons like New York city, from the intimacy of everyday items such as your very own Dairy to the exotic beauty of traditional garments like the Kimono. Take your pick and bring a classy design statement to your living room!*

*Moooi will continue to design new covers so that you can keep on bringing the latest style and feel into your home without having to invest in a whole new set of furniture.*

**This sofa will never be discontinued!**





**BOUTIQUE DOUBLE SEATER LEATHER  
PAPER SCREEN  
BOUTIQUE KIMONO COVER  
PAPER CHANDELIER L  
DELFT BLUE NO.8  
PAPER SIDE TABLE**



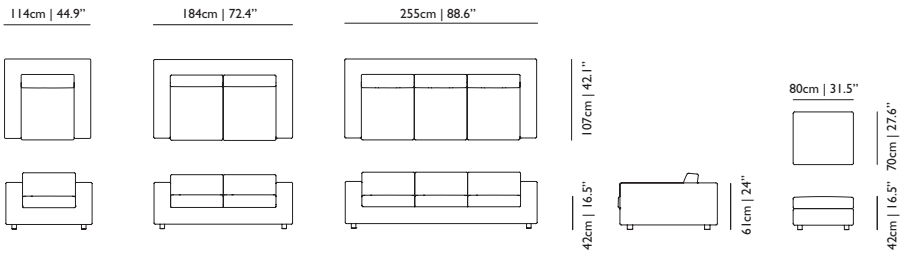
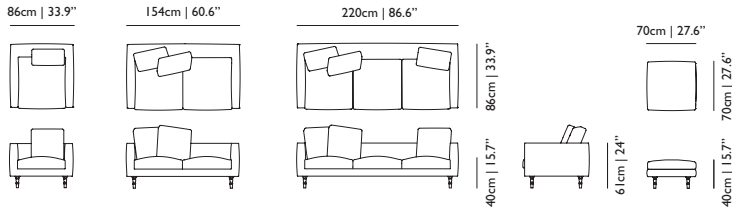



# BOUTIQUE LEATHER

## MARCEL WANDERS 2010

*upholstery: leather cover, naturally fire retardant*

*colour: black, white or brown*

**on commission**

*Available for all Boutique and Boutique XL naked sofa versions.*

*Is there anything more precious than the scent of leather and its texture on the palm of your hand? A timeless classic.*









**RANDOM LIGHT**  
**EGG GEISHA**  
**5 O'CLOCK CHAIR**  
**BOUTIQUE TRIPLE SOFA LEATHER**  
**CARPET MODEL 01**  
Super Hero by Erwin Olaf



**LUSTROGRAD**

[www.lustrograd.com](https://www.lustrograd.com/)



# BOUTIQUE BLANKETS

## MARCEL WANDERS 2005

material: 20% Polyester, 32% Cotton, 7% Polyamide, 41% Viscose

January



September



May



November

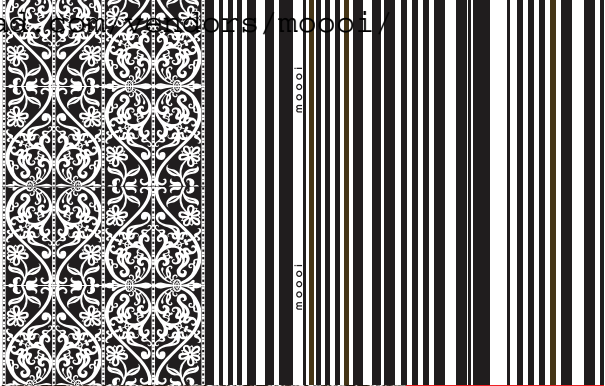



## **BOUTIQUE JESTER**

**MARCEL WANDERS, 2005**

*material: 50% Polyester, 2% Polyamide, 48% Viscose*

It is only the Jester who can do magic with questions; nothing is too serious for him to question.  
Some think he is a fool and some measure not his acts but his results!

# BOUTIQUE SOPHY

## MARCEL WANDERS 2008

material: 55% Polyester, 29% Linen, 1% Polyamide, 15% Viscose

*"Simplicity is the ultimate sophistication" Leonardo da Vinci*

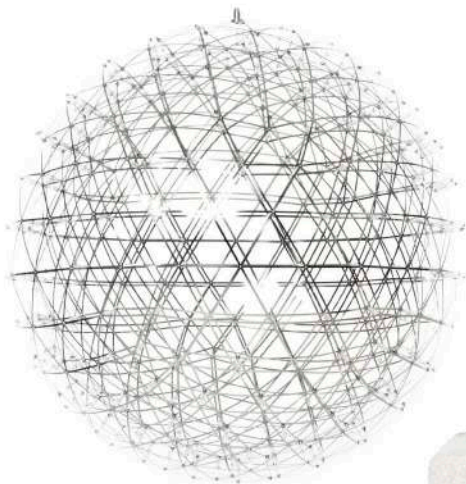

**RAIMOND  
BOUTIQUE SINGLE SEATER SOPHY  
CONTAINER BOWL**



The best and most comfortable seat will always be my daddy's lap.



## **BOUTIQUE DADDY**

**MARCEL WANDERS 2005**

*material: cover & cushion: 19% Polyester, 15% Linen, 51% Polyamide  
pillow: 100% Cotton*



pillows  
can be  
ordered  
seperatly







## BOUTIQUE PILLOWS

**MARCEL WANDERS 2005**

*Accessorize your own beautiful sofa with the Boutique pillows.*





*boutique pillow leather*



# BOUTIQUE SILVER

**MARCEL WANDERS 2005**

material: 48% Viscose, 50% Polyester, 2% Polyamide

*The poet paints his world using his silver heart creating a frozen forest of dreams.*



## **BOUTIQUE KIMONO**

### **MARCEL WANDERS 2008**

*material: 55% Polyester, 45% Viscose*

She walked by with the elegance of a cherry tree in blossom, silently. Suddenly her kimono made a swishing sound, like leaves in the wind, betraying her presence.

# BOUTIQUE CHAMELEON HALLINGDAL

MARCEL WANDERS 2005

material: 70% Wool, 30% Viscose

**CROCHET TABLE**

**DELFT BLUE NO.2**



Who wouldn't want to be a chameleon? Changing colors to your heart's content?  
Boutique Chameleon can!

## BOUTIQUE NEW YORK

### MARCEL WANDERS 2005

material: 14% Polyester, 12% Linen, 2% Polyamide, 35% Acryl, 37% Viscose

*You can walk a block in a minute, one avenue in about three: this sofa could last you a lifetime.*



## BOUTIQUE COCO

### MARCEL WANDERS 2005

material: 14% Polyester, 12% Linen, 2% Polyamide, 35% Acryl, 37% Viscose

*"Fashion fades, only style remains the same" Coco Chanel*



## **BOUTIQUE LACE** **MARCEL WANDERS 2008**

material: 21% Polyester, 27% Cotton, 44% Linen, 8% Viscose

*The poetry of transparencies and exquisite patterns, underlining and concealing the feminine soul.*



## **BOUTIQUE MANGA** **MARCEL WANDERS 2005**

material: cover: 29% Polyester, 71% Cotton

pillow: 18% Polyester, 46% Cotton, 5% Polyamide, 31% Viscose

cushion: 34% Polyester, 46% Acryl, 20% Viscose

*Where earth is dark and transparent, where flowers forget their colours.*





**DELFT BLUE NO.6**  
**PAPER CHANDELIER L**  
**PAPER SCREEN**  
**HORSE LAMP**  
**CORK**  
centaur by Edland Man

**LUSTROGRAD**  
ОПТОВЫЕ ПРОДАЖИ СВЕТОТЕХНИКИ



# BOUTIQUE MEDALLION

## MARCEL WANDERS 2005

material: cover: 16% Polyester, 34% Cotton, 15% Linen, 35% Viscose  
cushion: 34% Polyester, 46% Acryl, 20% Viscose  
pillow: 100% Cotton

*In front of the right wallpaper it may be completely camouflages, but in your house it will probably be the opposite.*



## BOUTIQUE XL TRAVIS

### MARCEL WANDERS 2005

material: 100% Trevira CS

colour: cappuccino-white

*This super strong moooi trevira CS cover, with its classy, linen-look pinstripe, was born to attract the eye and become a crisp, bright centerpiece: perfect for residential and contract use.*



## BOUTIQUE XL DEER

### MARCEL WANDERS 2005

material: cover: 16% Polyester, 34% Cotton, 15% Linen, 35% Viscose

*Who wouldn't like to visit a spring forest with white trees and flying pin-ups?*



## **BOUTIQUE XL EASY RIDER** **MARCEL WANDERS 2008**

*material: 26% Polyester, 74% Linen*

Freedom and speed, the rush of the wind on your face, images passing by you in fast motion while you look forward, chasing the horizon.



## **BOUTIQUE XL MANGA** **MARCEL WANDERS 2005**

*material: 29% Polyester, 71% Cotton*





*Try to find Marcel driving his Bisazza car and did you see Casper between the kissing elephants, the flowers and the lovers? I drew the moose especially for Hilde & Philippe – they made a great difference to the project and they love the moose as much as I love this sofa.*



# **BOUTIQUE DIARY**

**MARCEL WANDERS 2005**

*material: 46% Cotton, 31% Viscose, 18% Polyester, 5% Polyamide*

DS: //www.FirstLight.com/Vendor/...

**EMPEROR SUSPENDED 100**  
**CORK**  
**CARPET MODEL 06**  
**PAPER CABINET**  
**DELFT BLUE NO.1**  
**SMOKE DINING CHAIR**  
centaur by Edland Man

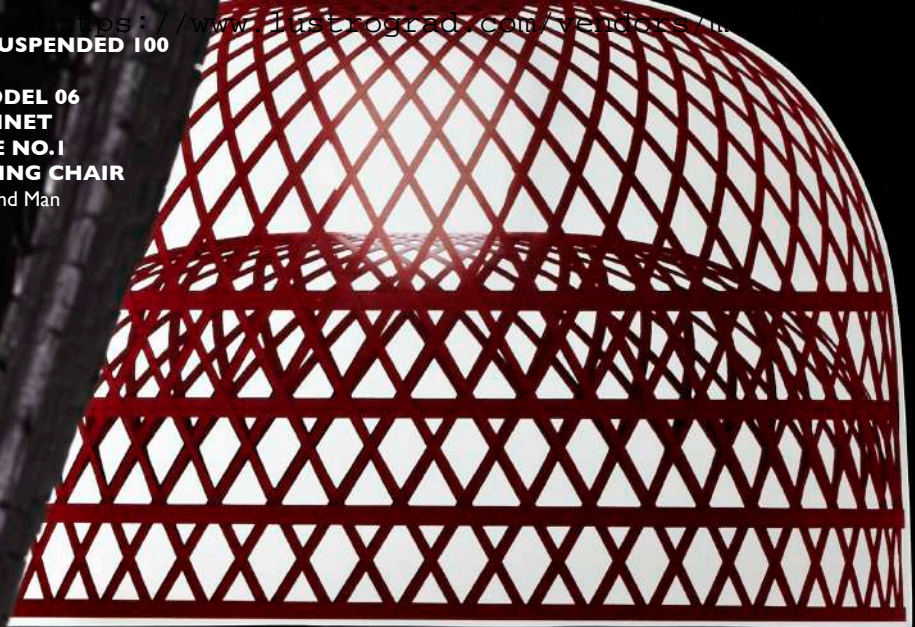

  
**LUSTROGRAD**  
ОПТОВІ ПРОДАЖИ СВЕТИЛЬНИКІВ

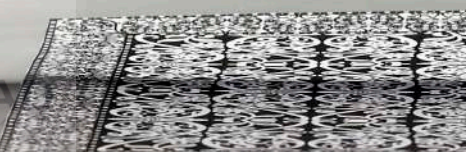

# BOUTIQUE CHAMELEON DIVINA MELANGE

MARCEL WANDERS 2005

material: 100% Wool









LUSTROGRAD  
Своиcые Продажи Мебельщиков



# THANK YOU FOR YOUR ATTENTION.

## **Moooi BV Headquarters**

Minervum 7003  
4817 ZL Breda  
PO Box 5703  
4801 EC Breda  
T +31 (0)76 5784444  
F +31 (0)76 5710621  
info@moooi.com  
sales@moooi.com (for sales-information)  
**www.moooi.com**

Art direction:  
Marcel Wanders

Creations manager:  
Desirée de Jong

Graphic design:  
Hannah Lenglet

Textual input:  
Marika Boso

Photography Moooi products:  
Maarten van Houten  
Nicole Marnati

Photography Milan Showroom, Manga & Haiku's:  
Nicole Marnati

Photography London Showroom:  
Peer Lindgreen

Rendering Random Floorlamp:  
CMC StudioWorks

All dimensions are in cm & inches.  
We advise the use of energy saving light bulbs for all our lighting.

**All rights reserved**  
**copyright © moooi bv, 2011**  
**For all text, layout and images.**

No text, layout or pictures may be used or reproduced for commercial purposes by third parties, including dealers, retailers, internetshops and other, without the prior written approval by Moooi B.V.  
The use of text, layout and images or its reproduction of such in press publications –both written and digital- is permitted, under the condition that Moooi is credited.

## **Moooi Showrooms**

### **Moooi Amsterdam**

Westerstraat 187  
1015 MA Amsterdam  
The Netherlands  
T +31 (0)20 5287760  
info@moooi-gallery.com  
www.moooi-gallery.com

### **Moooi Antwerp**

Riemstraat 39  
2000 Antwerp  
Belgium  
T +32 (0)474 510978

### **Moooi London**

White Building  
555, Harrow Road  
W10 4RH London  
United Kingdom  
T +44 (0)7980864112

### **Moooi Milano**

Via Tortona 37  
20144 Milano  
Italy  
T +39 02 48958313

### **Moooi New York**

138 Greene Street  
10012 New York  
United States  
T +1 (888) 6244370

<https://www.lustrograd.com/vendors/moooi/>